

DOCUMENT RESUME

ED 327 659

CE 056 669

AUTHOR Stephenson, David; Fulkerson, Dan, Ed.
 TITLE Residential and Light Commercial HVAC. Teacher Edition.
 INSTITUTION Mid-America Vocational Curriculum Consortium, Stillwater, Okla.
 PUB DATE 91
 NOTE 928p.
 AVAILABLE FROM Mid-American Vocational Curriculum Consortium, Inc., 1500 West Seventh Avenue, Stillwater, OK 74074 (order no. CN601701: \$41.50).
 PUB TYPE Guides - Classroom Use - Guides (For Teachers) (052)

EDRS PRICE MF06 Plus Postage. PC Not Available from EDRS.
 DESCRIPTORS *Air Conditioning; Air Conditioning Equipment; Behavioral Objectives; Buildings; Competency Based Education; Course Descriptions; Curriculum Guides; Fuel Consumption; Fuels; *Heating; Housing; Industrial Arts; Learning Activities; Postsecondary Education; Secondary Education; *Trade and Industrial Education; Units of Study; Utilities; *Ventilation

ABSTRACT

This curriculum guide contains 18 units of instruction for a competency-based course in residential and light commercial heating, ventilating, and air conditioning (HVAC). Introductory materials include a competency profile and an instructional/task analysis that correlates job training with related information for this course. Each instructional unit includes some or all of these basic components: performance objectives; suggested activities for teachers and students; information sheets; assignment sheets; job sheets; visual aids; tests; and answer keys. Units are planned for more than one lesson or class period. A list of tools, equipment, and materials and an alphabetical list of 38 references are provided. Unit topics include: psychometrics for residential HVAC; residential load calculations; residential duct design and sizing; residential air treatment; psychometrics for light commercial HVAC; load calculations for light commercial HVAC; light commercial system design; light commercial air treatment; standard gas-fired furnaces; high-efficiency gas-fired furnaces; oil-fired furnaces; electrical heating systems; cooling systems; heat pump systems; balance points; introduction to hydronics; customer relations; and service operations. (YLB)

 * Reproductions supplied by EDRS are the best that can be made *
 * from the original document. *

Residential and Light Commercial HVAC

ED327659

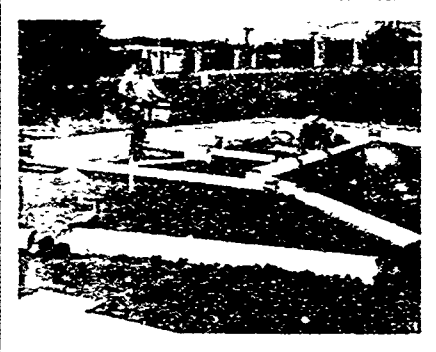

U.S. DEPARTMENT OF EDUCATION
Office of Educational Research and Improvement
EDUCATIONAL RESOURCES INFORMATION
CENTER (ERIC)

- This document has been reproduced as received from the person or organization originating it.
- Minor changes have been made to improve reproduction quality.
- Points of view or opinions stated in this document do not necessarily represent official OERI position or policy.

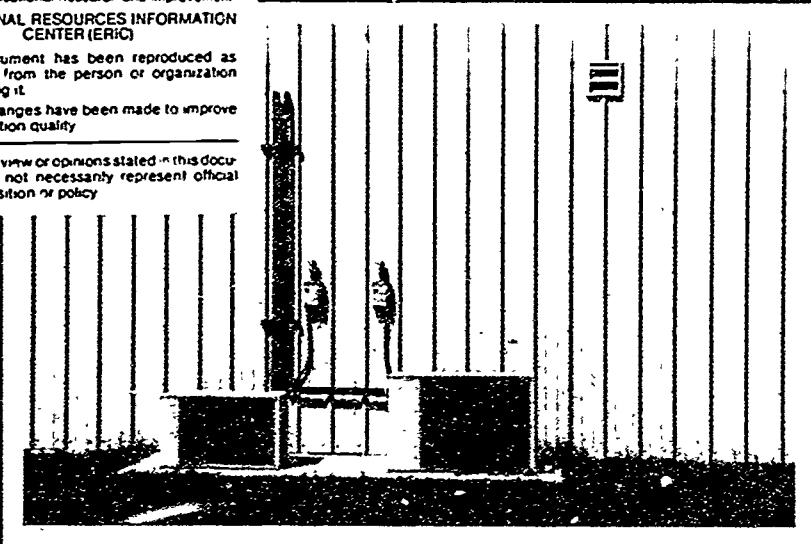

"PERMISSION TO REPRODUCE THIS MATERIAL IN MICROFICHE ONLY HAS BEEN GRANTED BY

D. L. Breason

TO THE EDUCATIONAL RESOURCES INFORMATION CENTER (ERIC)."

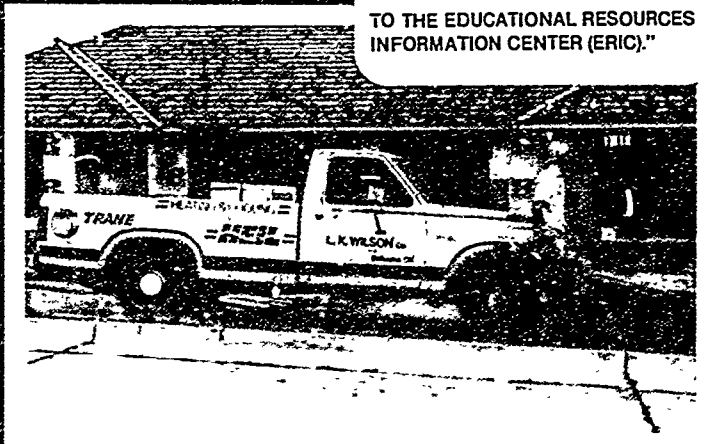

95056669

MAVCC

Teacher Edition



RESIDENTIAL AND LIGHT COMMERCIAL HVAC

Written by

David Stephenson

Edited by

Dan Fulkerson

Developed by

The Mid-America Vocational Curriculum Consortium, Inc.

Board of Directors

Sylvia Clark, Texas, Chairwoman
Donna Brookhart, Colorado, Vice-Chairwoman
Janet Huss, Iowa, Parliamentarian
Jean McEntire, Arkansas
Carol Fagan, Kansas
David Poston, Louisiana
Harley Schlichting, Missouri
Ann Masters, Nebraska
Ann Censon, Oklahoma
Larry Nelson, South Dakota

Jim Steward, Executive Director

©1991 by the Mid-America Vocational Curriculum Consortium, Inc.

All rights reserved. No part of this book may be reproduced in any form or by any means without written permission from the publisher.

Printed in the United States of American by the
Oklahoma Department of Vocational-Technical Education
Stillwater, OK 74074

Mid-America Vocational Curriculum Consortium, Inc.
1500 West Seventh
Stillwater, Oklahoma 74074-4364

RESIDENTIAL AND LIGHT COMMERCIAL HVAC

TABLE OF CONTENTS

Unit	I:	Psychrometrics for Residential HVAC	1
Unit	II:	Residential Load Calculations	55
Unit	III:	Residential Duct Design and Sizing	105
Unit	IV:	Residential Air Treatment	193
Unit	V:	Psychrometrics for Light Commercial HVAC	231
Unit	VI:	Load Calculations for Light Commercial HVAC	277
Unit	VII:	Light Commercial System Design	313
Unit	VIII:	Light Commercial Air Treatment	349
Unit	IX:	Standard Gas-Fired Furnaces	381
Unit	X:	High-Efficiency Gas-Fired Furnaces	495
Unit	XI:	Oil-Fired Furnaces	533
Unit	XII:	Electrical Heating Systems	627
Unit	XIII:	Cooling Systems	681
Unit	XIV:	Heat Pump Systems	753
Unit	XV:	Balance Points	895
Unit	XVI:	Introduction to Hydronics	937
Unit	XVII:	Customer Relations	1017
Unit	XVIII:	Service Operations	1035

FOREWORD

The energy crisis of the late 1970s inspired a national awareness to save energy. The crisis of the summer of 1990 served to endorse not only the awareness, but the need to re-emphasize constructive ways to conserve energy. This drive toward conservation is evident in the new directions being taken in heating, ventilating, and air conditioning. Standard cooling systems are being replaced by energy-efficient heat pumps. Air-to-air exchangers provide both the residential and light commercial user with a new cost-efficient way to handle air. In heating, high-efficiency furnaces have efficiency ratings that range above 95%. Refrigerant is being reclaimed and recycled, not only to save money, but to save the earth's protective ozone layer.

As products improve, maintenance and service procedures change. The modern HVAC technician has new systems to learn about and service. We like to think that *Residential and Light Commercial HVAC* will expand the horizons of HVAC technicians. The addition of valuable light commercial applications to this text opens a new area of job skills and an opportunity for HVAC technicians to gain an added measure of employability. After all, that's what MAVCC's competency-based instructional materials are designed to accomplish.

Sylvia Clark, Chairwoman
Board of Directors
Mid-America Vocational
Curriculum Consortium

Jim Steward
Executive Director
Mid-America Vocational
Curriculum Consortium

ACKNOWLEDGEMENTS

The Resource Committee which planned and approved materials for *Residential and Light Commercial HVAC* included individuals with impressive credentials in HVAC. All committee members have had hands-on experience with both residential and light commercial HVAC. Some committee members have had extended experience with public utilities. Other members have instructed or are instructing HVAC classes and still others operate their own HVAC businesses either full or part time. We thank this impressive committee which included:

Don Havens, Instructor, Metropolitan Vocational Center, Little Rock, Arkansas.

Ron Shelton, Instructor, Pike's Peak Community College, Colorado Springs, Colorado.

Del Winston, Instructor, Platte County Area Vocational School, Platte City, Missouri.

Dave Swett, HVAC Specialist, Nebraska Public Power District, Columbus, Nebraska.

Al Thomas, President, Advanced Mechanical Incorporated, Bismarck, North Dakota.

Roger Henseley, Marketing Services Consultant, Oklahoma Gas and Electric Company, Oklahoma City, Oklahoma

Sherman Hanes, Instructor, Memorial Campus, Tulsa Area Vocational-Technical School, Tulsa, Oklahoma

Curt Neuharth, Instructor, Mitchell Vocational-Technical Institute, Mitchell, South Dakota.

We also thank **Jerry McKnight** of Sioux City, Iowa, for his help with initial planning.

A special thank you goes to the manufacturers, both large and small, who graciously permitted us to reproduce graphic materials and procedures that have significantly enhanced the value of this text. Credit lines appear throughout the book to document their valuable contributions.

To the Air Conditioning Contractors of America we extend gratitude for their permission to use valuable materials and illustrations from the impressive array of ACCA literature. The many ACCA credit lines in the text document the broad range of ACCA expertise.

Another special thank you goes to **David Stephenson**, our writer, for his devotion to a demanding project and to his wife, **Yarimah**, whose typing skills (and patience) helped it all happen.

A final thank you goes to the Communications Center, the Art Department, and the Print Shop of the Oklahoma Department of Vocational-Technical Education. The professional work by the people in those departments have not only helped produce this text—they have made it look good!

RESIDENTIAL AND LIGHT COMMERCIAL HVAC COMPETENCY PROFILE

Name: _____

Directions. Evaluate the student using the rating scale below. Write the appropriate number to indicate the degree of competency achieved. The descriptions associated with each of the numbers focuses on a level of student performance for each of the tasks listed. The written test scoreline is provided for optional teacher use. It may not be applicable in all cases.

Option A

Rating scale:	4 — Skilled —	Can perform job with no additional training.
	3 — Moderately Skilled —	Has performed job during training program; limited additional training may be required.
	2 — Limited Skill —	Has performed job during training program; additional training is required to develop skill.
	1 — Unskilled —	Is familiar with process, but is unable to perform job.
	0 — No Exposure —	No information or practice provided during training program, complete training required.
	NA —	Non-applicable

Option B

Yes — Can perform with no additional training
No — Is unable to perform satisfactorily

_____ Unit I: Psychrometrics for Residential HVAC

- _____ 1. Determine relative humidity when only dry-bulb and wet-bulb temperatures are known.
- _____ 2. Determine dew point when only dry-bulb and wet-bulb temperatures are known.
- _____ 3. Determine how outside air should be conditioned to provide a comfortable humidity and temperature combination in winter heating.
- _____ 4. Determine how outside air should be conditioned to provide a comfortable humidity and temperature combination in summer cooling.
- _____ 5. Determine the relative humidity of a conditioned space.
- _____ 6. Determine the relative humidity of an outdoor space.
- _____ 7. Determine the wet-bulb temperature of the air inside a duct.

COMPETENCY PROFILE

_____ 8. _____

_____ Written Test Score

_____ Unit II: Residential Load Calculations

_____ 1. Calculate heat loss and heat gain for a residence using "entire house" for a quick calculation.

_____ 2. Determine shaded and unshaded glass areas for use in heat gain calculations.

_____ 3. Calculate heat loss for a residence, room by room.

_____ 4. Calculate heat gain for a residence, room by room.

_____ 5. _____

_____ Written Test Score

_____ Unit III: Residential Duct Design and Sizing

_____ 1. Solve problems using the friction loss per 100 feet chart.

_____ 2. Solve problems using the friction chart for flex duct.

_____ 3. Design an air distribution system from a drawing.

_____ 4. Determine the pressure drop across an evaporator coil.

_____ 5. Determine the CFM being delivered by a selected forced air system.

_____ 6. _____

_____ Written Test Score

_____ Unit IV: Residential Air Treatment

_____ 1. Install a humidifier with low voltage controls.

_____ 2. Install an electric air cleaner.

_____ 3. _____

_____ Written Test Score

COMPETENCY PROFILE

_____ Unit V: Psychrometrics for Light Commercial HVAC

- _____ 1. Determine relative humidity when dry bulb and wet bulb temperatures are known.
- _____ 2. Determine dew point and enthalpy when dry bulb and wet bulb temperatures are known.
- _____ 3. Determine the condition of air presented to the evaporator coil when outside air for ventilation is mixed with room return air.
- _____ 4. Plot a load triangle on a psychrometric chart when return and supply air dry bulb/wet bulb temperatures are known.
- _____ 5. Calculate a load triangle for a given light commercial installation.
- _____ 6. _____

_____ Written Test Score

_____ Unit VI: Light Commercial Load Calculations

- _____ 1. Calculate the heat gain for an office.
- _____ 2. Calculate the heat loss for an office.
- _____ 3. _____

_____ 4. Written Test Score

_____ Unit VII: Light Commercial System Design

- _____ 1. Determine velocity and volume of air flowing in a duct.
- _____ 2. _____

_____ Written Test Score

_____ Unit VIII: Light Commercial Air Treatment

- _____ 1. Determine the number of electronic air cleaners needed for an office.
- _____ 2. _____

_____ Written Test Score

_____ Unit IX: Standard Gas-Fired Furnaces

- _____ 1. Trace the high and low voltage circuits of a gas furnace.
- _____ 2. Construct wiring diagrams for gas furnaces.

COMPETENCY PROFILE

- _____ 3. Size a gas piping system.
- _____ 4. Install a gas furnace.
- _____ 5. Start and adjust a gas furnace.
- _____ 6. Disassemble, inspect, and reassemble an upflow gas furnace.
- _____ 7. Perform maintenance on a gas furnace.
- _____ 8. Troubleshoot a gas furnace on a "no heat" complaint.
- _____ 9. Install a retrofit package to replace a standing pilot with a cycling pilot.
- _____ 10. _____

_____ Written Test Score

_____ Unit X: High-Efficiency Gas-Fired Furnaces

- _____ 1. Trace the high voltage circuitry for an induced draft furnace.
- _____ 2. Trace the low voltage circuitry for an induced draft furnace.
- _____ 3. Troubleshoot an induced draft furnace on a "no heat" complaint.
- _____ 4. Troubleshoot a condensing furnace on a "no heat" complaint.
- _____ 5. _____

_____ Written Test Score

_____ Unit XI: Oil-Fired Furnaces

- _____ 1. Install an oil-fired furnace.
- _____ 2. Perform a stack temperature test on an oil-fired furnace.
- _____ 3. Perform a CO₂ test and determine the combustion efficiency of an oil-fired furnace.
- _____ 4. Perform a smoke test on an oil-fired furnace.
- _____ 5. Perform an "overfire draft" and a "flue draft" test on an oil-fired furnace.
- _____ 6. Perform fuel pump service on an oil-fired furnace.
- _____ 7. _____

_____ Written Test Score

COMPETENCY PROFILE

_____ Unit XII: Electrical Heating Systems

- _____ 1. Install, start, and check an electrical heating unit.
- _____ 2. Disassemble, inspect, and reassemble an electric furnace.
- _____ 3. Troubleshoot an electric furnace.
- _____ 4. Perform maintenance on an electric furnace.
- _____ 5. _____

_____ Written Test Score

_____ Unit XIII: Cooling Systems

- _____ 1. Trace the cooling circuit on a single phase package heat/cool unit.
- _____ 2. Trace the cooling circuit on a 7½ ton three phase rooftop unit.
- _____ 3. Troubleshoot an air conditioning condenser section on a "no cooling" complaint.
- _____ 4. Use a charging table to check the charge in a capillary cooling system.
- _____ 5. Perform maintenance on an air conditioner.
- _____ 6. _____

_____ Written Test Score

_____ Unit XIV: Heat Pump Systems

- _____ 1. Trace operational circuits for a heat pump in the cooling mode.
- _____ 2. Trace operational circuits for first stage heating in a heat pump.
- _____ 3. Trace operational circuits for a heat pump in the defrost mode.
- _____ 4. Trace operational circuits for second stage supplemental heat in a heat pump
- _____ 5. Trace operational circuits for a fossil fuel heat pump system in first stage heat mode above 45°F outdoor ambient. (Adjustable)
- _____ 6. Trace operational circuits for a fossil fuel heat pump system in first stage heat mode below 40°F outdoor ambient. (Adjustable)
- _____ 7. Wire a control system for a heat pump.
- _____ 8. Troubleshoot a heat pump indoor section in the cooling mode.

COMPENTENCY PROFILE

- _____ 9. Perform maintenance on an indoor section of a heat pump in the cooling mode.
- _____ 10. Troubleshoot a heat pump on a "no cooling" complaint.
- _____ 11. Troubleshoot a heat pump outdoor section on an "insufficient cooling" complaint.
- _____ 12. Perform maintenance on the indoor section of a heat pump.
- _____ 13. Troubleshoot supplemental heat on a heat pump.
- _____ 14. Perform maintenance on heat pump supplemental heating.
- _____ 15. Troubleshoot a heat pump on a "no heat" complaint when the compressor will not run.
- _____ 16. Troubleshoot a heat pump on a "no heat" complaint when the compressor runs but cycles on compressor overload.
- _____ 17. Troubleshoot a heat pump on an "insufficient heat" complaint when the compressor will run.
- _____ 18. Check operation of an Essex solid state time-temperature defrost control.
- _____ 19. Check operation of a Ranco E-15 mechanical time-temperature defrost control.
- _____ 20. Check operation of an Essex 149-600 solid state demand defrost control.
- _____ 21. _____

_____ Written Test Score

_____ Unit XV: Balance Points

- _____ 1. Size a heat pump on the cooling load.
- _____ 2. Plot balance points for a heat pump at given design conditions.
- _____ 3. Locate equipment to obtain maximum COP from a heat pump.
- _____ 4. Set outdoor thermostats for proper staging of auxiliary heat.
- _____ 5. _____

_____ Written Test Score

COMPETENCY PROFILE

_____ Unit XVI. Introduction to Hydronics

- _____ 1. Lay out a series loop single circuit hydronic system with boiler located under floor of dining room.
- _____ 2. Select boiler and expansion tanks.
- _____ 3. Make a trial selection of pump and select pipe size for series loop system.
- _____ 4. _____

_____ Written Test Score

_____ Unit XVII: Customer Relations

- _____ 1. Respond to problem situations.
- _____ 2. _____

_____ Written Test Score

_____ Unit XVIII: Service Operations

- _____ 1. Complete a return goods tag.
- _____ 2. _____

_____ Written Test Score

COMMENTS:

Evaluator: _____ Date: _____

*Permission to duplicate this profile is granted.

RESIDENTIAL AND LIGHT COMMERCIAL HVAC

INSTRUCTIONAL / TASK ANALYSIS

JOB TRAINING: What the
Worker Should Be Able to Do
(Psychomotor)

RELATED INFORMATION:
What the Worker Should Know
(Cognitive)

UNIT I: PSYCHROMETRICS FOR RESIDENTIAL HVAC

1. Terms and definitions
 2. Basic information found on a psychrometric chart
 3. The location of dry-bulb temperature readings
 4. The location of wet-bulb temperature readings
 5. The location of dew point temperature readings
 6. The location of relative humidity readings
 7. Three basic cumulative psychrometric processes
 8. Typical air-conditioning processes that can be shown on a psychrometric chart
 9. Sling psychrometers
 10. Operating a sling psychrometer
-
11. Determine relative humidity when only dry-bulb and wet-bulb temperatures are known. (Assignment Sheet #1)
 12. Determine dew point when only dry-bulb and wet-bulb temperatures are known. (Assignment Sheet #2)

**JOB TRAINING: What the
Worker Should Be Able to Do
(Psychomotor)**

13. Determine how outside air should be conditioned to provide a comfortable humidity and temperature combination in winter heating. (Assignment Sheet #3)
14. Determine how outside air should be conditioned to provide a comfortable humidity and temperature combination in summer cooling. (Assignment Sheet #3)
15. Determine the relative humidity of a conditioned space. (Job Sheet #1)
16. Determine the relative humidity of an outdoor space. (Job Sheet #2)
17. Determine the wet-bulb temperature of the air inside a duct. (Job Sheet #3)

**RELATED INFORMATION: What
the Worker Should Know
(Cognitive)**

UNIT II: RESIDENTIAL LOAD CALCULATION

1. Terms and definitions
 2. The value of standardized load calculations
 3. Factors in determining heat loss and heat gain
 4. Steps in calculating heat transfer multipliers
 5. Factors to consider when sizing heating equipment
 6. Factors to consider when sizing cooling equipment
 7. Ways structural modifications can affect equipment selection
-
8. Calculate heat loss and heat gain for a residence using "entire house" for a quick calculation. (Assignment Sheet #1)
 9. Determine shaded and unshaded glass areas for use in heat gain calculations. (Assignment Sheet #2)

JOB TRAINING: What the Worker Should Be Able to Do (Psychomotor)

10. Calculate heat loss for a residence, room by room. (Assignment Sheet #3)
11. Calculate heat gain for a residence, room by room. (Assignment Sheet #4)

RELATED INFORMATION: What the Worker Should Know (Cognitive)

UNIT III: RESIDENTIAL DUCT DESIGN AND SIZING

1. Terms and definitions
2. Types of supply duct systems
3. Factors affecting system design and the effects they have on the system
4. Major steps in air system design and their procedures
5. Factors affecting return air duct design
6. Location of registers and grilles
7. Advantages and disadvantages for locations of registers and grilles
8. Climatic zone conditions
9. Control devices and their applications
10. Factors to consider in the distribution of conditioned air
11. Grille design factors and their meanings
12. Outlet placement and recommended velocities
13. Air duct calculators
14. Solve problems using the friction loss per 100 feet chart. (Assignment Sheet #1)
15. Solve problems using the friction chart for flex duct. (Assignment Sheet #2)

JOB TRAINING: What the Worker Should Be Able to Do (Psychomotor)

RELATED INFORMATION: What the Worker Should Know (Cognitive)

16. Design an air distribution system from a drawing. (Assignment Sheet #3)
17. Determine the pressure drop across an evaporator coil. (Job Sheet #1)
18. Determine the CFM being delivered by a selected forced air system. (Job Sheet #2)

UNIT IV: RESIDENTIAL AIR TREATMENT

1. Terms and definitions
 2. Air contaminants that affect humans
 3. The advantages of maintaining proper humidity in a residence
 4. Factors which affect humidity in a residence
 5. Common types of residential filtering equipment
 6. Operation of an electronic air cleaner
 7. Operation of a dehumidifier
 8. Operation of a typical humidifier with a forced air furnace
 9. Air-to-air exchangers
 10. Radon monitoring
-
11. Install a humidifier with low voltage controls. (Job Sheet #1)
 12. Install an electronic air cleaner. (Job Sheet #2)

UNIT V: PSYCHROMETRICS FOR LIGHT COMMERCIAL HVAC

1. Terms and definitions
2. Using a psychrometric chart for light commercial applications

**JOB TRAINING: What the
Worker Should Be Able to Do
(Psychomotor)**

**RELATED INFORMATION: What
the Worker Should Know
(Cognitive)**

3. Specific humidity
 4. Enthalpy
 5. Specific volume
 6. The load triangle
-
7. Determine relative humidity when dry bulb and wet bulb temperatures are known. (Assignment Sheet #1)
 8. Determine dew point and enthalpy when dry bulb and wet bulb temperatures are known. (Assignment Sheet #2)
 9. Determine the condition of air presented to the evaporator coil when outside air for ventilation is mixed with room return air. (Assignment Sheet #3)
 10. Plot a load triangle on a psychrometric chart when return and supply air dry bulb/wet bulb temperatures are known. (Assignment Sheet #4)
 11. Calculate a load triangle for a given light commercial installation. (Job Sheet #1)

UNIT VI: LIGHT COMMERCIAL LOAD CALCULATIONS

1. Terms and definitions
2. *Manual N* and light commercial load calculations
3. Load components for heat loss and heat gain in a light commercial space
4. Other sources of light commercial heat gain
5. The winter humidification load
6. Time of day corrections

JOB TRAINING: What the Worker Should Be Able to Do (Psychomotor)

RELATED INFORMATION: What the Worker Should Know (Cognitive)

7. Selecting equipment for a normal cooling application
8. U values
9. Calculate the heat gain for an office. (Assignment Sheet #1)
10. Calculate the heat loss for an office. (Assignment Sheet #2)

UNIT VII: LIGHT COMMERCIAL SYSTEM DESIGN

1. Terms and definitions
2. Structural and space considerations in system design
3. Equipment location in system design
4. Control requirements in system design
5. Electrical considerations in system design
6. How ceiling design affects system design
7. Air distribution and system design
8. Noise and system design
9. Odor control and system design
10. Fire codes and system design
11. Filters and system design
12. Humidification and system design
13. Duct materials and system design
14. The methods of sizing duct
15. Twinning furnaces
16. Balancing an air distribution system

JOB TRAINING: What the Worker Should Be Able to Do (Psychomotor)

RELATED INFORMATION: What the Worker Should Know (Cognitive)

17. Determine velocity and volume of air flowing in a duct. (Job Sheet #1)

UNIT VIII: LIGHT COMMERCIAL AIR TREATMENT

1. Terms and definitions
2. Comfort level in a light commercial structure
3. Air cleaners and existing light commercial structures
4. Common electronic air cleaning devices for light commercial applications
5. Performance factors for air cleaner applications
6. Basic air patterns for air cleaners
7. Capacity sizing
8. Mechanical filters
9. Humidification for light commercial applications
10. Air-to-air exchangers for light commercial structures

11. Determine the number of electronic air cleaners needed for an office. (Assignment Sheet #1)

UNIT IX: STANDARD GAS-FIRED FURNACES

1. Terms and definitions
2. Furnace classifications
3. Gas furnace safety
4. Parts of the combustion triangle
5. Types of gas furnaces and their applications
6. Major components of a standing pilot furnace

**JOB TRAINING: What the
Worker Should Be Able to Do
(Psychomotor)**

**RELATED INFORMATION: What
the Worker Should Know
(Cognitive)**

7. Automatic ignition systems and their operations
8. Components of a gas burner assembly
9. Types of gas valves and their characteristics
10. Components of a combination electric gas valve
11. Characteristics of heat exchangers
12. Characteristics of draft diverters
13. Types of blower assemblies
14. Components of a control system
15. The functions of a transformer
16. Types of thermostats and their functions
17. Limit switch operation
18. Fan switch operation
19. Combination fan-limit switch operation
20. Pilot light operation
21. Thermocouple operation
22. Pilot safety operation
23. Potential sources for thermocouple failure
24. Potential sources of fan switch failure
25. Potential sources of transformer failure
26. Potential sources of high limit switch failure

JOB TRAINING: What the
Worker Should Be Able to Do
(Psychomotor)

RELATED INFORMATION: What
the Worker Should Know
(Cognitive)

27. Potential sources of gas valve failure
28. Potential sources of fan relay failure
29. Potential blower section failures and component sources
30. Potential sources of heat exchanger failure
31. Potential sources of pilot safety failure
32. Factors needed to determine gas pipe sizing
33. Energy conservation devices designed for retrofitting
34. Set back thermostats
35. Intermittent ignition systems
36. Vent dampers and their uses
37. Combustion air for a gas furnace
38. Trace the high and low voltage circuits of a gas furnace. (Assignment Sheet #1)
39. Construct wiring diagrams for gas furnaces. (Assignment Sheet #2)
40. Size a gas piping system. (Assignment Sheet #3)
41. Install a gas furnace. (Job Sheet #1)
42. Start and adjust a gas furnace. (Job Sheet #2)
43. Disassemble, inspect, and reassemble an upflow gas furnace. (Job Sheet #3)
44. Perform maintenance on a gas furnace. (Job Sheet #4)

JOB TRAINING: What the Worker Should Be Able to Do (Psychomotor)

RELATED INFORMATION: What the Worker Should Know (Cognitive)

45. Troubleshoot a gas furnace on a "no heat" complaint. (Job Sheet #5)
46. Install a retrofit package to replace a standing pilot with a cycling pilot. (Job Sheet #6)

UNIT X: HIGH-EFFICIENCY GAS-FIRED FURNACES

1. Terms and definitions
 2. Induced draft furnaces
 3. Condensing furnaces
 4. Pulse furnaces
 5. Safety with high-efficiency furnaces
 6. Maintaining and servicing high-efficiency furnaces
-
7. Trace the high voltage circuitry for an induced draft furnace. (Assignment Sheet #1)
 8. Trace the low voltage circuitry for an induced draft furnace. (Assignment Sheet #2)
 9. Troubleshoot an induced draft furnace on a "no heat" complaint. (Job Sheet #1)
 10. Troubleshoot a condensing furnace on a "no heat" complaint. (Job Sheet #2)

UNIT XI: OIL-FIRED FURNACES

1. Terms and definitions
2. Oil furnace types and their performance characteristics
3. Oil storage tanks
4. Major components of an oil burner assembly

**JOB TRAINING: What the
Worker Should Be Able to Do
(Psychomotor)**

**RELATED INFORMATION: What
the Worker Should Know
(Cognitive)**

5. Operation of a gun type atomizing burner
 6. Flame retention
 7. Visual flame detection and cad cell location
 8. Troubleshooting cad cell systems
 9. Combustion chambers
 10. Fuel pumps
 11. Nozzles
 12. Nozzle service guide
 13. Venting
 14. Normal operating sequence
 15. Electrodes
 16. Combustion testing
 17. Burner components and required maintenance
-
18. Install an oil-fired furnace. (Job Sheet #1)
 19. Perform a stack temperature test on an oil-fired furnace. (Job Sheet #2)
 20. Perform a CO₂ test and determine the combustion efficiency of an oil-fired furnace. (Job Sheet #3)
 21. Perform a smoke test on an oil-fired furnace. (Job Sheet #4)
 22. Perform an "overfire draft" and a "flue draft" test on an oil-fired furnace. (Job Sheet #5)
 23. Perform fuel pump service on an oil-fired furnace. (Job Sheet #6)

**JOB TRAINING: What the
Worker Should Be Able to Do
(Psychomotor)**

**RELATED INFORMATION: What
the Worker Should Know
(Cognitive)**

UNIT XII: ELECTRICAL HEATING SYSTEMS

1. Terms and definitions
2. Types of electrical heating systems
3. Duct heaters and electric heaters
4. Components of electric heating equipment
5. Causes of common failures of electric heating equipment components
6. Staging methods and their operations
7. Installing duct heaters
8. Installing heaters smaller or larger than ductwork
9. Installing slip-in heaters
10. Installing flange-type heaters
11. General recommendations for installing duct heaters
12. Gathering information for system sizing
13. Formulas for sizing electrical heating systems
14. Install, start, and check an electrical heating unit. (Job Sheet #1)
15. Disassemble, inspect, and reassemble an electric furnace. (Job Sheet #2)
16. Troubleshoot an electric furnace. (Job Sheet #3)
17. Perform maintenance on an electric furnace. (Job Sheet #4)

JOB TRAINING: What the
Worker Should Be Able to Do
(Psychomotor)

RELATED INFORMATION: What
the Worker Should Know
(Cognitive)

UNIT XIII: COOLING SYSTEMS

1. Terms and definitions
 2. Basic mechanical components of a cooling system
 3. Additional components found on some residential and light commercial units
 4. Electrical components and their functions
 5. Steps in a cooling cycle
 6. Indoor fan operation
 7. Compressor motor failures and ways to detect them
 8. Compressor mechanical failures and ways to detect them
 9. Causes of compressor failures
 10. Problems with condensing units and their probable causes
 11. Functions of low side section components in an air conditioner
 12. Problems of low side sections and their probable causes
 13. Steps in using a charging table
 14. Guidelines for charging a system
 15. The scroll compressor
 16. Evaporative coolers
 17. Evaporative cooling applications
 18. Refrigerant recovery and recycling
19. Trace the cooling circuit on a single phase package heat/cool unit. (Assignment Sheet #1)

**JOB TRAINING: What the
Worker Should Be Able to Do
(Psychomotor)**

20. Trace the cooling circuit on a 7½ ton three phase rooftop unit. (Assignment Sheet #2)
21. Troubleshoot an air conditioning condenser section on a "no cooling" complaint. (Job Sheet #1)
22. Use a charging table to check the charge in a capillary cooling system. (Job Sheet #2)
23. Perform maintenance on an air conditioner. (Job Sheet #3)

**RELATED INFORMATION: What
the Worker Should Know
(Cognitive)**

UNIT XIV: HEAT PUMP SYSTEMS

1. Terms and definitions
2. Heat pump configurations
3. Components of a heat pump
4. Components of a 4-way reversing valve
5. Operation of a 4-way reversing valve in the heating and cooling modes
6. Metering devices and check valves
7. A heat pump in the defrost mode
8. Methods of defrost initiation and termination
9. Components of a heat pump indoor section
10. Components failures of heat pumps
11. The heat pump touch test
12. Special precautions for replacing reversing valves
13. Special precautions for driers

**JOB TRAINING: What the
Worker Should Be Able to Do
(Psychomotor)**

20. Trace operational circuits for a heat pump in the cooling mode. (Assignment Sheet #1)
21. Trace operational circuits for first stage heating in a heat pump. (Assignment Sheet #2)
22. Trace operational circuits for a heat pump in the defrost mode. (Assignment Sheet #3)
23. Trace operational circuits for second stage supplemental heat in a heat pump. (Assignment Sheet #4)
24. Trace operational circuits for a fossil fuel heat pump system in first stage heat mode above 45°F outdoor ambient. (Assignment Sheet #5)
25. Trace operational circuits for a fossil fuel heat pump system in first stage heat mode below 40°F outdoor ambient. (Assignment Sheet #6)
26. Wire a control system for a heat pump. (Job Sheet #1)
27. Troubleshoot a heat pump indoor section in the cooling mode. (Job Sheet #2)
28. Perform maintenance on an indoor section of a heat pump in the cooling mode. (Job Sheet #3)

**RELATED INFORMATION: What
the Worker Should Know
(Cognitive)**

14. General guidelines for supplemental heating strips
15. Temperature controls
16. Fossil fuel/add-on heat pumps
17. Water source heat pumps
18. Closed loop/ground source heat pumps
19. Rules for good heat pump operation

JOB TRAINING: What the
Worker Should Be Able to Do
(Psychomotor)

RELATED INFORMATION: What
the Worker Should Know
(Cognitive)

29. Troubleshoot a heat pump on a "no cooling" complaint. (Job Sheet #4)
30. Troubleshoot a heat pump outdoor section on an "insufficient cooling" complaint. (Job Sheet #5)
31. Perform maintenance on the indoor section of a heat pump. (Job Sheet #6)
32. Troubleshoot supplemental heat on a heat pump. (Job Sheet #7)
33. Perform maintenance on heat pump supplemental heating. (Job Sheet #8)
34. Troubleshoot a heat pump on a "no heat" complaint when the compressor will not run. (Job Sheet #9)
35. Troubleshoot a heat pump on a "no heat" complaint when the compressor runs but cycles on compressor overload. (Job Sheet #10)
36. Troubleshoot a heat pump on an "insufficient heat" complaint when the compressor will run. (Job Sheet #11)
37. Check operation of an Essex solid state time-temperature defrost control. (Job Sheet #12)
38. Check operation of a Ranco E-15 mechanical time-temperature defrost control. (Job Sheet #13)
39. Check operation of an Essex 149-600 solid state demand defrost control. (Job Sheet #14)

JOB TRAINING: What the
Worker Should Be Able to Do
(Psychomotor)

RELATED INFORMATION: What
the Worker Should Know
(Cognitive)

UNIT XV: BALANCE POINTS

1. Terms and definitions
2. The COP of a direct electrical heating element and the COP of a heat pump
3. The COP of a heat pump at a given design temperature
4. Balance points and their relation to COP
5. Balance points and typical stages in heating continuity
6. Factors needed to plot balance points
7. A heat pump performance curve from manufacturer's specifications
8. Balance point #1 and design conditions
9. Additional balance points and design conditions
10. The procedure for sizing a heat pump on the cooling load
11. Advantages of controlled heating stages
12. Installation considerations related to heat pump performance
13. Size a heat pump on the cooling load. (Assignment Sheet #1)
14. Plot balance points for a heat pump at given design conditions. (Assignment Sheet #2)
15. Locate equipment to obtain maximum COP from a heat pump. (Assignment Sheet #3)
16. Set outdoor thermostats for proper staging of auxiliary heat. (Job Sheet #1)

**JOB TRAINING: What the
Worker Should Be Able to Do
(Psychomotor)**

**RELATED INFORMATION: What
the Worker Should Know
(Cognitive)**

UNIT XVI: INTRODUCTION TO HYDRONICS

1. Terms and definitions
2. Basic types of hydronic systems
3. Classifications of hydronic systems with their water temperature/pressure characteristics
4. Types of common hydronic system designs
5. Common hydronic system designs and their advantages and disadvantages
6. Design water temperature
7. Design water temperature drop
8. Design water flow rates through circuits
9. Flow rates through terminal units and their tubing sizes
10. Placement of terminal units
11. Terminal units, their characteristics and uses
12. Steps in the selection and sizing of terminal units
13. Fuels, ratings, and selection of boilers
14. Advantages and disadvantages of types of residential expansion tanks
15. Steps in selection of residential expansion tanks
16. Types, design, and sizing of residential pumps
17. Factors in the selection of residential pumps

**JOB TRAINING: What the
Worker Should Be Able to Do
(Psychomotor)**

26. Lay out a series loop single circuit hydronic system with boiler located under floor of dining room. (Assignment Sheet #1)
27. Select boiler and expansion tanks. (Assignment Sheet #2)
28. Make a trial selection of pump and select pipe size for series loop system. (Assignment Sheet #3)

**RELATED INFORMATION: What
the Worker Should Know
(Cognitive)**

18. Steps in the selection of residential pumps
19. Factors affecting pipe sizing
20. The procedure for selection of pipe sizes
21. Types of hydronic specialties and their characteristics and uses
22. Steps in designing a hydronic system
23. Integrated systems
24. Pulse combustion boilers
25. Wall-mounted boilers

UNIT XVII: CUSTOMER RELATIONS

1. Terms and definitions
2. Ways good personal habits contribute to good customer relations
3. General rules in dealing with customers
4. Basic rules for service calls
5. Ways to turn service calls into good customer relations opportunities
6. Ways to handle an irritated customer

JOB TRAINING: What the Worker Should Be Able to Do (Psychomotor)

RELATED INFORMATION: What the Worker Should Know (Cognitive)

7. Ways vehicle operations affect customer relations
8. Ways to earn a customer's respect
9. Respond to problem situations. (Assignment Sheet #1)

UNIT XVIII: SERVICE OPERATIONS

1. Terms and definitions
2. Objectives of good service operations
3. Guidelines for maintaining inventory control
4. Guidelines for maintaining records of installations, service calls, and maintenance calls
5. Ways to gather information for a good equipment file
6. Procedure for handling return goods
7. Special precautions in handling return goods
8. Vehicle use, maintenance, and safety
9. Basic rules for scheduling and service calls
10. Ways to avoid legal problems with equipment and service
11. Other operations items and how they contribute to good service operations
12. How to handle accounting and money with service customers
13. The most important rule of good service operations
14. Complete a return goods tag. (Assignment Sheet #1)

USE OF THIS PUBLICATION

Instructional Units

Residential and Light Commercial HVAC contains 18 units of instruction. Each instructional unit includes some or all of the basic components of a unit of instruction, performance objectives, suggested activities for teachers and students, information sheets, assignment sheets, job sheets, visual aids, tests, and answers to the tests. Units are planned for more than one lesson or class period of instruction.

Careful study of each instructional unit by the teacher will help to determine.

- A. The amount of material that can be covered in each class period
- B. The skills which must be demonstrated
 - 1. Supplies needed
 - 2. Equipment needed
 - 3. Amount of practice needed
 - 4. Amount of class time needed for demonstrations
- C. Supplementary materials such as pamphlets or filmstrips that must be ordered
- D. Resource people who must be contacted

Objectives

Each unit of instruction is based on performance objectives. These objectives state the goals of the course, thus providing a sense of direction and accomplishment for the student.

Performance objectives are stated in two forms. unit objectives, stating the subject matter to be covered in a unit of instruction, and specific objectives, stating the student performance necessary to reach the unit objective.

Since the objectives of the unit provide direction for the teaching-learning process, it is important for the teacher and students to have a common understanding of the intent of the objectives. A limited number of performance terms have been used in the objectives for this curriculum to assist in promoting the effectiveness of the communication among all individuals using the materials.

Reading of the objectives by the student should be followed by a class discussion to answer any questions concerning performance requirements for each instructional unit.

Teachers should feel free to add objectives which will fit the material to the needs of the students and community. When teachers add objectives, they should remember to supply the needed information, assignment and/or job sheets, and criterion tests.

Suggested Activities for the Instructor

Each unit of instruction has a suggested activities section outlining steps to follow in accomplishing specific objectives. Duties of instructors will vary according to the particular unit, however, for best use of the material they should include the following. provide students with objective sheet, information sheet, assignment sheets, and job sheets, preview filmstrips, make transparencies, and arrange for resource materials and people, discuss unit and specific objectives and information sheet, give test. Teachers are encouraged to use any additional instructional activities and teaching methods to aid students in accomplishing the objectives.

Information Sheets

Information sheets provide content essential for meeting the cognitive (knowledge) objectives in the unit. The teacher will find that the information sheets serve as an excellent guide for presenting the background knowledge necessary to develop the skill specified in the unit objective.

Students should read the information sheets before the information is discussed in class. Students may take additional notes on the information sheets.

Transparency Masters

Transparency masters provide information in a special way. The students may see as well as hear the material being presented, thus reinforcing the learning process. Transparencies may present new information or they may reinforce information presented in the information sheets. They are particularly effective when identification is necessary.

Transparencies should be made and placed in the notebook where they will be immediately available for use. Transparencies direct the class's attention to the topic of discussion. They should be left on the screen only when topics shown are under discussion.

Assignment Sheets

Assignment sheets provide paper and pencil activities to aid the student in practicing and developing the knowledge necessary for skill development. These may be given to the student for completion in class or used for homework assignments. Answer sheets are provided which may be used by the student and/or teacher for checking student progress.

Job Sheets

Job sheets are an important segment of each unit. The instructor should be able to demonstrate the skills outlined in the job sheets. Procedures outlined in the job sheets give direction to the skill being taught and allow both student and teacher to check student progress toward the accomplishment of the skill. Job sheets provide a ready outline for students to follow if they have missed a demonstration. Job sheets also furnish potential employers with a picture of the skills being taught and the performances which might reasonably be expected from a person who has had this training.

Practical Tests

Practical tests provide the instructor with an evaluation instrument for each of the job sheets.

Test and Evaluation

Written and performance tests have been constructed to measure student achievement of each objective listed in the unit of instruction. Individual test items may be pulled out and used as a short test to determine student achievement of a particular objective. This kind of testing may be used as a daily quiz and will help the teacher spot difficulties encountered by students in their efforts to accomplish the unit objective. Test items for objectives added by the teacher should be constructed and added to the test.

Test Answers

Test answers are provided for each unit. These may be used by the teacher and/or student for checking student achievement of the objectives.

RESIDENTIAL AND LIGHT COMMERCIAL HVAC

Tools, Equipment, and Materials Lists

Service technician's tool pouch or tool box as presented in MAVCC's *Air Conditioning and Refrigeration: Fundamentals*

Test and maintenance equipment

Sling psychrometer
Manometer
Inclined Manometer
Velometer
Volt-ohm-ammeter
Ammeter
Millivolt meter
Service thermometer
Dial thermometer
Stack thermometer, 1000°F
Combustion test kit
CO₂ tester
Draft gauge
0-300 PSIG gauge
Combustion efficiency slide rule

Specialty tools

Awl
Aviation Snips
Measuring tape
Level
Inspection mirror w/swivel
Flashlight
Industrial vacuum cleaner
Reciprocating saw and blades

Miscellaneous supplies

Oil can
Motor lubricant to specifications
Utility pan
Clean shop cloths
Assorted containers
Kerosene for cleaning
Crushed ice supply
Distilled water
1/4" plastic tubing, 3'
1/4" drill and bits
Duct tape
Assorted sheet metal screws
#14 insulated stranded wire
Thermostat cable, 2-wire #18
Utility brush
Pencil and paper

Equipment requirements

Wall thermostat
SPST relay, 24V coil
Essex solid state time-temperature control
Essex 149-600 solid state demand defrost control
Ranco E-15 mechanical time-temperature control
Retrofit package for a cycling pilot

System requirements

Forced air heating system
Humidifier and accessories
Electronic filter and accessories
Light commercial HVAC system with blower performance chart
Standard gas-fired furnace
High-efficiency gas-fired furnace
Oil-fired furnace
Cooling system
Heat pump system
Fossil fuel/add-on heat pump system

Special requirement

Safety glasses are required for all job sheets in this text.

RESIDENTIAL AND LIGHT COMMERCIAL HVAC
Alphabetical List of References
Used in Developing this Text

- A. *Air Conditioning Installation and Service*. Lavergne, TN 37086. Heil-Quaker Corporation, 1988.
- B. *Air Conditioning Service Manual*. Lavergne, TN 37086. Heil-Quaker Corporation, 1985.
- C. *AIRXCHANGE Fresh-Air Recovery Systems* (Product Brochure). Rockland, MA 02370: AIRXCHANGE, Inc., 1988.
- D. Althouse, Andrew D., and Carl H. Turnquist and Alfred C. Bracciano. *Modern Refrigeration and Air Conditioning*, South Holland, IL: The Goodheart-Wilcox Company, Inc., 1988.
- E. "Bacharach Gas Burner Combustion Testing, Bulletin 4006." Pittsburg, PA 15238: Bacharach, Inc., 1987.
- F. "Becket Equipment Catalog." Elyria, OH 44036. R. W. Beckett Corporation, 1990.
- G. *Closed-Loop/Ground-Source Heat Pump Systems Installation Guide*. Stillwater, OK 74078: Oklahoma State University, 1988.
- H. *Condensing Gas Furnace Service Manual*. Lavergne, TN 37086. Heil-Quaker Corporation, 1988.
- I. Copeland Corporation Training Materials. Sidney, OH 45362. The Copeland Corporation, 1988.
- J. Eckes, William, and Dan Fulkerson. *Air Conditioning and Refrigeration, Book Four*. Stillwater, OK 74074. Mid-America Vocational Curriculum Consortium, Inc., 1981.
- K. *Engineering Catalog*. Louisville, KY: American Air Filter, 1988.
- L. "Engineering Report No. 149, Duct System Measurements." Waterville, OH 43801. United McGill Corporation, 1987.
- M. *Equipment Selection and System Design Procedures for Commercial Summer and Winter Air Conditioning (using unitary equipment), Manual Q*. Washington, DC 20036: Air Conditioning Contractors of America, no date.
- N. "Evaporative Cooler Use and Care Manual." Phoenix, AZ 85034. ArvinAir, Inc., no date.
- O. *Heat Pump Design, Service and Application*. Dallas, TX 75240. Lennox Industries Inc., Education Department, 1979.
- P. *Heat Pump Installation and Service*. Lavergne, TN 37086. Heil-Quaker Training Center, 1987.
- Q. *Heat Pump Split Systems*. Lavergne, TN 37086-1985. Heil-Quaker Corporation, 1989.

- R. *Heat Pump Training Manual*. Fort Smith, AR 72906: Rudd Air Conditioning Division, no date.
- S. *Heat Recovery Ventilators Radon Applications*. Rockland, MA 02370: AIRXCHANGE, Inc., 1988.
- T. "Installation Manual for DHA, DHB, DHC, and DHD Series Nykelkrom® Duct Heaters." Cookeville, TN 39501: Tutco, Inc., no date.
- U. *Intermittent Ignition Gas Furnace Installation and Service*. Lavergne, TN 37086. Heil-Quaker Corporation, 1987.
- V. Lang, Paul V. *Principles of Air Conditioning, Fourth Edition*. Albany, NY 12212: Delmar Publishers Inc., 1987.
- W. *Manual E, Room Air Distribution Considerations*. Washington, DC 20036. Air Conditioning Contractors of America, 1965.
- X. *Manual G, Selection of Distribution System*. Washington, DC: 20036: Air Conditioning Contractors of America, 1965.
- Y. *Manual L, Installation Practices for Warm Air Heating and Cooling Systems*. Washington, DC 20036: Air Conditioning Contractors of America, 1969.
- Z. *Manual N, Commercial Load Calculation for Commercial Summer and Winter Air Conditioning*. 1513 Sixteenth Street., N.W., Washington, D.C. 20036. Air Conditioning Contractors of America, 1988.
- AA. "Oil Burner Combustion Testing, Bulletin 4011." Pittsburg, PA 15238 2878: Bacharach, Inc., 1989.
- BB. *Power Vent Furnace Service Manual*. Lavergne, TN 37086: Heil-Quaker Corporation, 1988.
- CC. *Refrigeration and Air Conditioning, Second Edition*. Englewood Cliffs, NJ. Air Conditioning and Refrigeration Institute/Prentice-Hall, Inc., 1987.
- DD. Rutkowski, Hank. *Heat Pump Systems. Principles Applications, Manual H, Second Edition*. Washington, DC 20036: Air Conditioning Contractors of America, 1984.
- EE. Rutkowski, Hank. *Manual D, Duct Design for Residential Winter and Summer Air Conditioning and Equipment Selection*. Washington, DC 20036. Air Conditioning Contractors of America, 1986.
- FF. Rutkowski, Hank. *Manual J Load Calculation for Residential Winter and Summer Air Conditioning*. (Seventh edition.) Washington, DC 20036: Air Conditioning Contractors of America, 1986.
- GG. Rutkowski, Hank. *Manual P First Edition, Psychrometrics. Theory & Applications*. Washington, DC 20036: Air Conditioning Contractors of America, 1985.
- HH. *Servicing and Installing Natural Gas Appliances*. Tulsa, OK. Oklahoma Natural Gas Company, 1985.
- II. *Smokeeater Engineering Catalog*. Cincinnati, OH. United Air Specialists, 1989.

- JJ. *Understanding the Friction Chart*. Washington, DC 20036: Air Conditioning Contractors of America, 1967.
- KK. Whitman, William C., and William M. Johnson. *Refrigeration and Air Conditioning Technology*. Albany, NY 12212: Delmar Publishers, Inc., 1987.
- LL. Yates, David, *Oil Furnace Installation and Service*. Lavergne, TN: Heil-Quaker Corporation, no date.

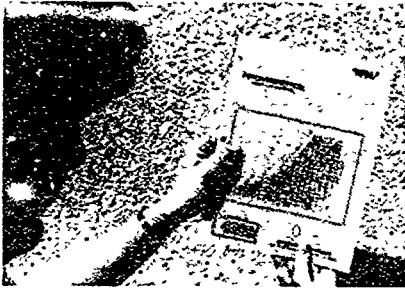

PSYCHROMETRICS FOR RESIDENTIAL HVAC UNIT I

UNIT OBJECTIVE

After completion of this unit, the student should be able to correctly operate a sling psychrometer and plot basic psychrometric relationships on a psychrometric chart. These competencies will be demonstrated by completing the assignment and job sheets, and by scoring a minimum of 85 percent on the written test.

SPECIFIC OBJECTIVES

After completion of this unit, the student should be able to:

1. Match terms related to psychrometrics with their correct definitions.
2. Select true statements concerning basic information found on a psychrometric chart.
3. Complete a psychrometric chart showing the location of dry-bulb temperature readings.
4. Complete a psychrometric chart showing the location of wet-bulb temperature readings.
5. Complete a psychrometric chart showing the location of dew point temperature readings.
6. Complete a psychrometric chart showing the location of relative humidity readings.
7. Complete statements concerning three basic cumulative psychrometric processes.
8. Select true statements concerning typical air-conditioning processes that can be shown on a psychrometric chart.
9. Complete statements concerning sling psychrometers.
10. Solve problems concerning operating a sling psychrometer.
11. Determine relative humidity when only dry-bulb and wet-bulb temperatures are known. (Assignment Sheet #1)
12. Determine dew point when only dry-bulb and wet-bulb temperatures are known. (Assignment Sheet #2)

SPECIFIC OBJECTIVES

13. Determine how outside air should be conditioned to provide a comfortable humidity and temperature combination in winter heating. (Assignment Sheet #3)
14. Determine how outside air should be conditioned to provide a comfortable humidity and temperature combination in summer cooling. (Assignment Sheet #4)
15. Demonstrate the ability to:
 - a. Determine the relative humidity of a conditioned space. (Job Sheet #1)
 - b. Determine the relative humidity of an outdoor space. (Job Sheet #2)
 - c. Determine the wet-bulb temperature of the air inside a duct. (Job Sheet #3)

**PSYCHROMETRICS FOR RESIDENTIAL HVAC
UNIT I**

SUGGESTED ACTIVITIES

- A. Obtain additional materials and/or invite resource people to class to supplement/reinforce information provided in this unit of instruction.

(NOTE: This activity should be completed prior to the teaching of this unit.)

- B. Make transparency from the transparency master included with this unit.
- C. Provide students with objective sheet.
- D. Discuss unit and specific objectives.
- E. Provide students with information and assignment sheets.
- F. Discuss information and assignment sheets.

(NOTE: Use the transparencies as needed to enhance the information.)

- G. Provide students with job sheets.
- H. Discuss and demonstrate the procedures outlined in the job sheets.
- I. Integrate the following activities throughout the teaching of this unit:
1. Demonstrate the proper use of a sling psychrometer to obtain wet-bulb readings.
 2. Prepare a psychrometric chart and demonstrate the air conditioning processes that can be shown on a psychrometric chart in reference to item VIII in the information sheet.
 3. Meet individually with students to evaluate their progress through this unit of instruction, and indicate to them possible areas for improvement.
- J. Give test.
- K. Evaluate test.
- L. Reteach if necessary.

REFERENCES USED IN WRITING THIS UNIT

- A. Rutkowski, Hank. *Psychrometrics. Theory & Applications, Manual P. First Edition.* Washington, DC 20036: Air Conditioning Contractors of America, 1985.
- B. Althouse, Andrew D., and Carl H. Turnquist and Alfred F. Bracciano. *Modern Refrigeration and Air Conditioning.* South Holland, IL 60473. The Goodheart-Willcox Company, Inc., 1988.

SUGGESTED ACTIVITIES

- C. Eckes, William, and Dan Fulkerson. *Air Conditioning and Refrigeration, Book Three*. Stillwater, OK 74074: Mid-America Vocational Curriculum Consortium, 1981.

**PSYCHROMETRICS FOR RESIDENTIAL HVAC
UNIT I**

INFORMATION SHEET

- I. **Terms and definitions**
- A. **Psychrometrics** — The science of measuring and changing the properties of air
 - B. **Psychrometric chart** — A visual summary of the properties of air, including or relating to temperature, moisture content, density and heat content
 - C. **Dry-bulb temperature** — The air temperature as measured by an ordinary thermometer
 - D. **Wet-bulb temperature** — The air temperature as measured by a thermometer whose bulb is covered with a wet wick and moved in air at a velocity of one thousand feet per minute
 - E. **Relative humidity** — The percentage of moisture in the air compared to the total amount of moisture the air could hold at the same temperature and barometric pressure
 - F. **Air dew point** — The temperature at which moisture condenses as liquid on a surface
 - G. **Latent heat** — The addition of heat in a situation where moisture content increases but air temperature does not change
 - H. **Latent cooling** — The removal of heat in a situation where moisture content decreases but air temperature does not change
 - I. **Sensible heat** — The addition of heat in a situation where air temperature increases but moisture content does not change
 - J. **Sensible cooling** — The removal of heat in a situation where air temperature decreases but moisture content does not change
 - K. **Sensible heat factor** — The relationship of sensible heat to total heat
 - L. **Enthalpy** — The total sensible and latent heat in air as measured in Btu's per pound of dry air
- II. **Basic information found on a psychrometric chart (Transparency 1)**
- A. Dry-bulb temperature
 - B. Wet-bulb temperature
 - C. Dew point temperature

INFORMATION SHEET

D. Relative humidity

III. Reading dry-bulb temperature on a psychrometric chart (Figure 1)

- A. The degree reading is represented by a vertical line.
- B. Degree readings advance from left to right in units of 5 degrees on a straight horizontal line at the bottom of the chart.
- C. Think of dry bulb lines as representing readings on a thermometer.

FIGURE 1

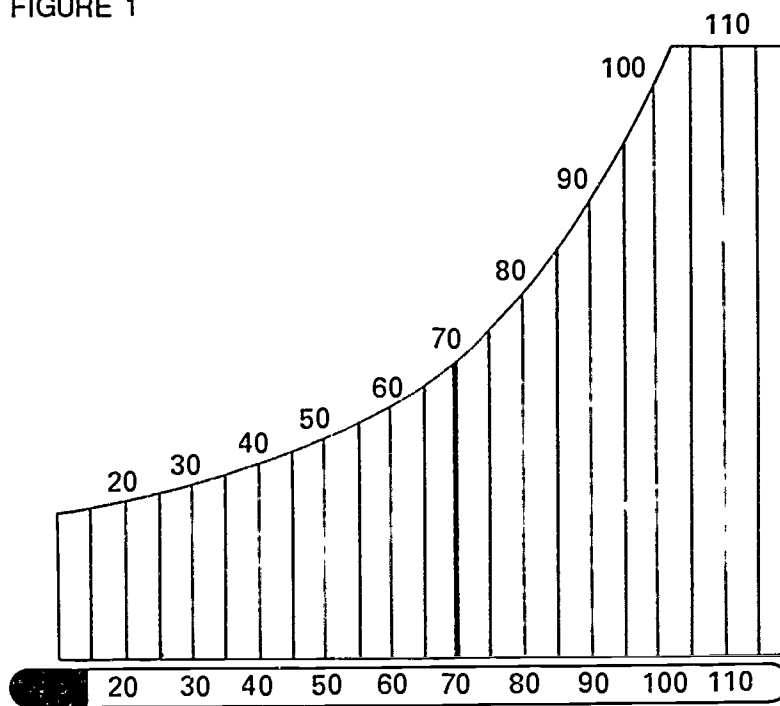

Dry-Bulb Lines

IV. Reading wet-bulb temperature on a psychrometric chart (Figure 2)

- A. The degree reading is represented by a diagonal line.
- B. Degree readings advance from lower left to upper middle in units of 5 degrees on a curved line.

INFORMATION SHEET

- C. Think of wet-bulb lines as representing readings on a wet-bulb thermometer.

FIGURE 2

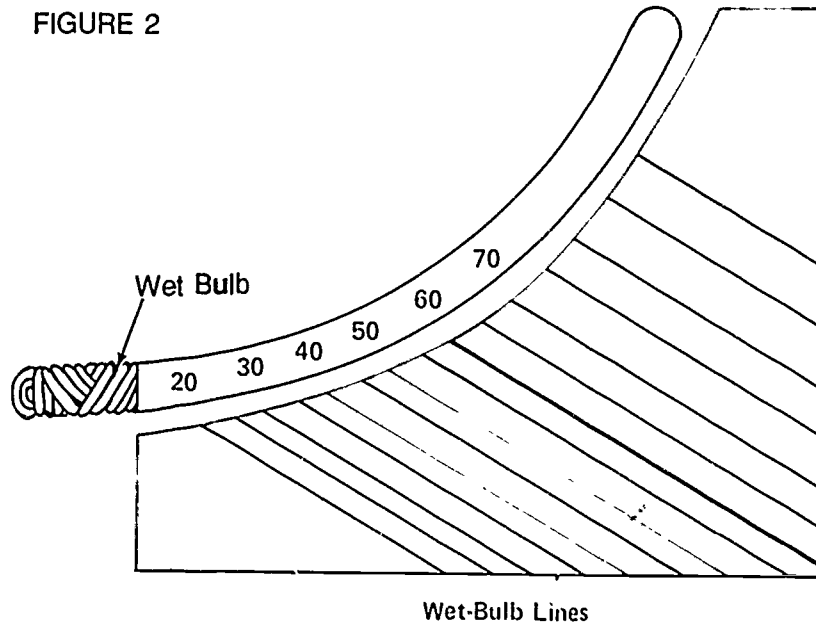

- V. Reading dew point on a psychrometric chart (Figure 3)

- A. The degree reading is represented by a horizontal line.
- B. Degree readings advance from lower left to upper middle in units of 5 degrees on a curved line.

FIGURE 3

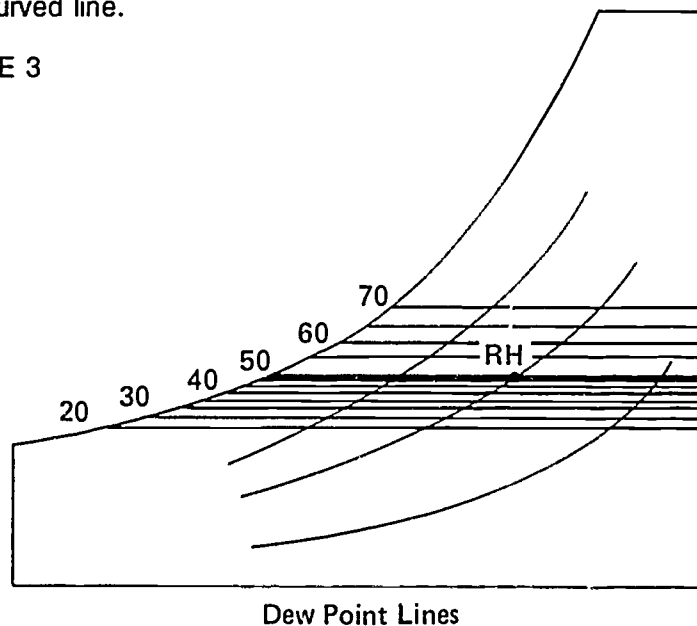

INFORMATION SHEET

VI. Reading relative humidity on a psychrometric chart (Figure 4)

- A. Percentages are expressed in units of ten ranging from 0 to 100.
- B. Percentage readings advance from bottom left to lower and upper right on curved lines.
- C. Relative humidity is read at the point of intersection of the dry-bulb and wet-bulb lines.

FIGURE 4

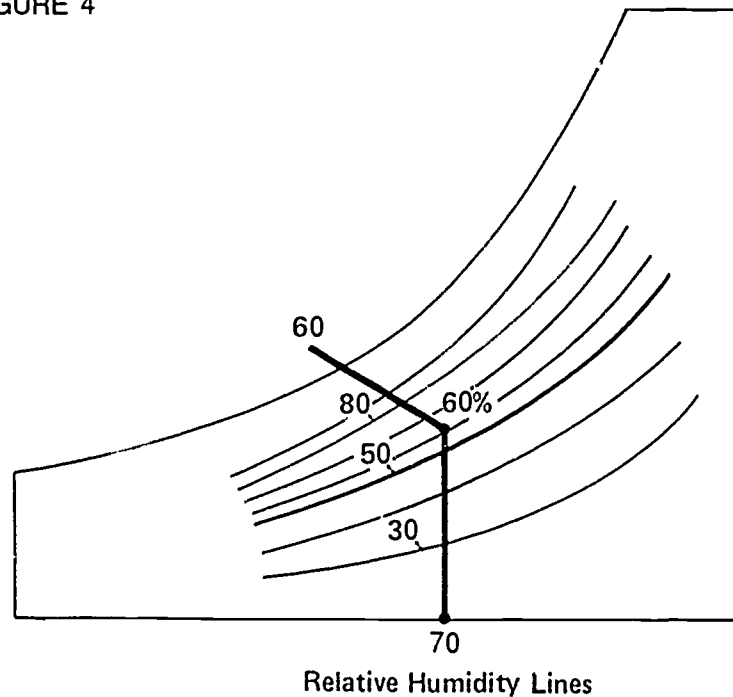

VII. Basic cumulative psychrometric processes

- A. Cooling and humidifying
- B. Cooling and dehumidifying
- C. Heating and humidifying

VIII. Typical air-conditioning processes that can be shown on a psychrometric chart

- A. Outdoor air adds heat and moisture when it is mixed with indoor air.
- B. Heat and moisture are removed as they pass through the air-conditioning apparatus.

INFORMATION SHEET

- C. An air mixture of correct temperature and humidity can be determined to maintain a comfort zone in a given area.

IX. Sling psychrometers

- A. Sling psychrometers are devices with dual thermometers and are used to measure dry-bulb and wet-bulb temperatures at the same time.
- B. Two standard thermometers are mounted side by side on a sling psychrometer, but one of them is covered with a wet wick that should be saturated with distilled water before it is used.
- C. The handle of a sling psychrometer is used to whirl the device rapidly around in the air, fast enough to duplicate a speed of one thousand feet per minute in order to get an accurate wet-bulb reading. (Figure 5)

FIGURE 5



X. Operating a sling psychrometer

- A. If the sling psychrometer is in a case, pull the mounted thermometers out until they are free to be whirled in the air.
- B. If the psychrometer has a water reservoir, fill it with enough distilled water to make sure the wet bulb covering is saturated.
- C. Whirl the psychrometer and record the initial dry-bulb and wet-bulb readings.
- D. Wait a minute, whirl the psychrometer again and take second readings, and record them.
- E. Compare the two readings to see if they are close enough to verify accuracy.
- F. If the psychrometer case is so equipped, use the dry-bulb and wet-bulb scales to get an instantaneous relative humidity reading. (Figure 6)

INFORMATION SHEET

FIGURE 6

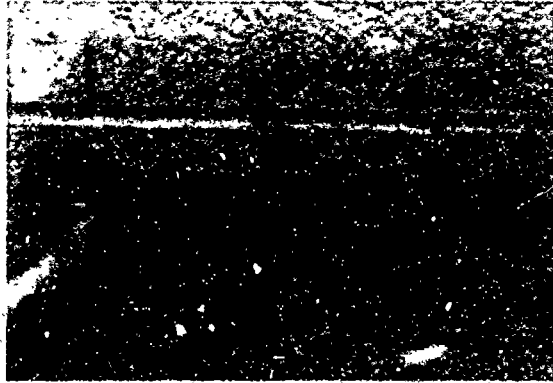

Psychrometric Chart

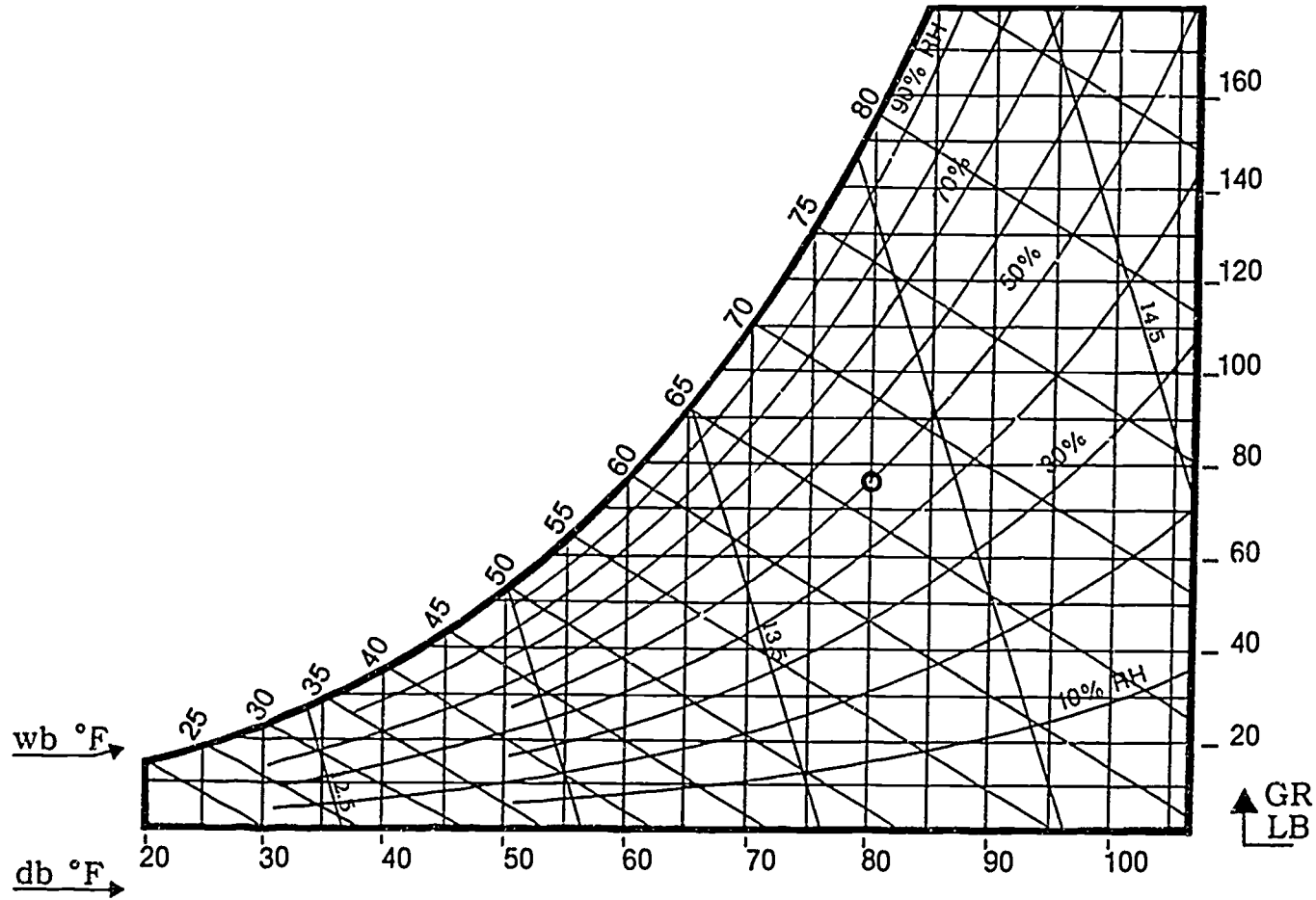

Courtesy Air Conditioning Contractors of America

**PSYCHROMETRICS FOR RESIDENTIAL HVAC
UNIT I****ASSIGNMENT SHEET #1 — DETERMINE RELATIVE HUMIDITY WHEN
ONLY DRY-BULB AND WET-BULB TEMPERATURES ARE KNOWN**

Directions: Use a ruler and pencil to complete the psychrometric chart in Figure 1 by plotting the correct lines to determine relative humidity.

Procedure:

1. Draw a vertical line up the chart from the point on the dry-bulb temperature scale that reads 72°F.
 2. Draw a diagonal line down the chart from the point on the wet-bulb temperature scale that reads 54°F until it intersects the dry-bulb temperature line.
 3. The relative humidity is determined by the point where the lines of dry-bulb and wet-bulb temperatures intersect, and this gives a relative humidity reading of approximately _____ percent.
- Have your instructor evaluate your calculation.

FIGURE 1

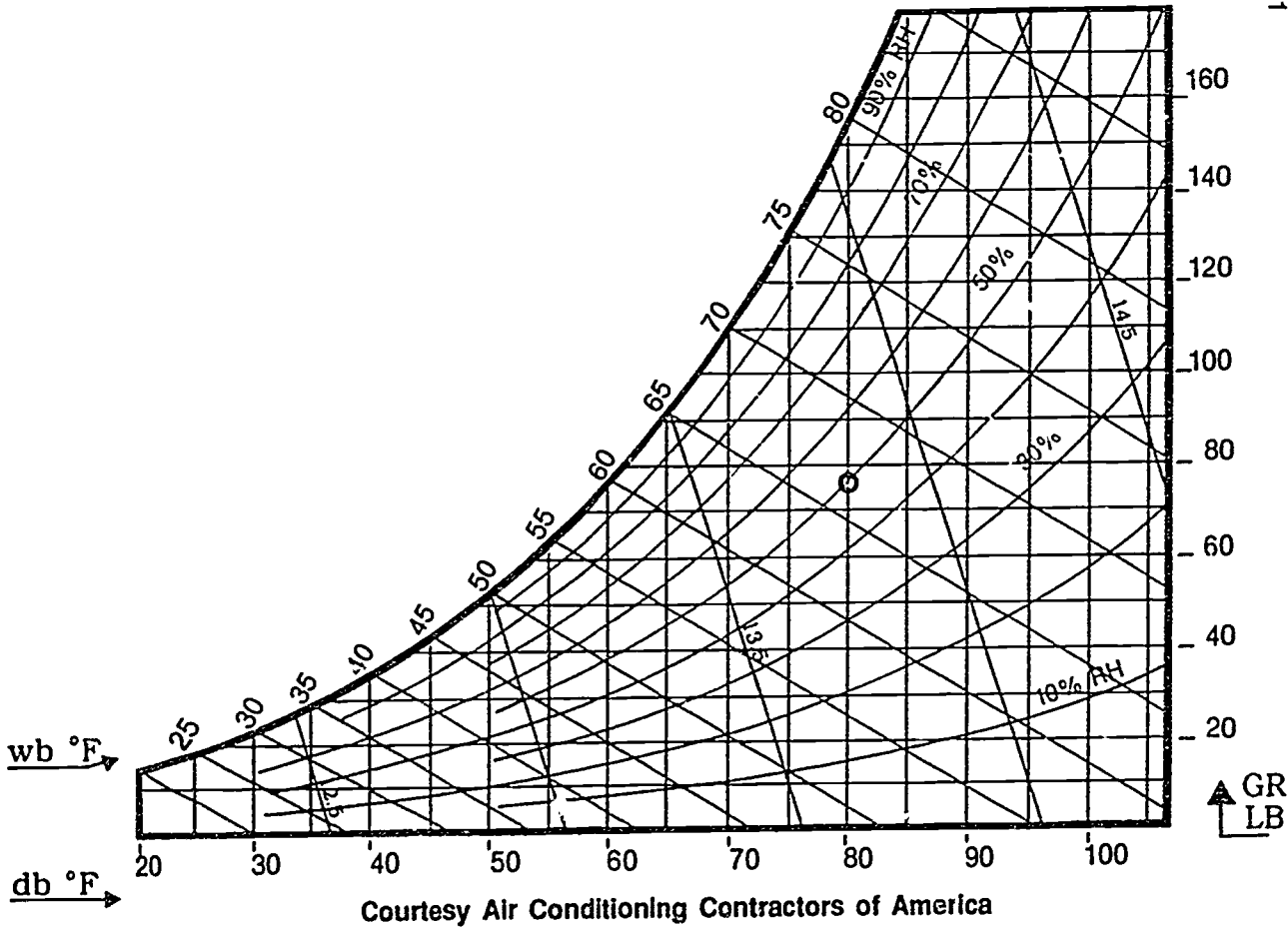

**PSYCHROMETRICS FOR RESIDENTIAL HVAC
UNIT I**

**ASSIGNMENT SHEET #2 — DETERMINE DEW POINT WHEN ONLY
DRY-BULB AND WET-BULB TEMPERATURES ARE KNOWN**

Directions: Use a ruler and pencil to complete the psychrometric chart in Figure 1 by plotting the correct lines to determine dew point.

Procedure:

1. Draw a vertical line up the chart from the point where the dry-bulb temperature reads 75°F.
2. Draw a diagonal line down the chart from the point where the wet-bulb temperature reads 60°F until it intersects the line drawn in item 1.
3. From the point where the two lines in item 2 intersect, draw a horizontal line to the left of the chart.
4. Where the line in item 3 intersects the dew point scale the reading is _____.

Have your instructor evaluate your calculation.

FIGURE 1

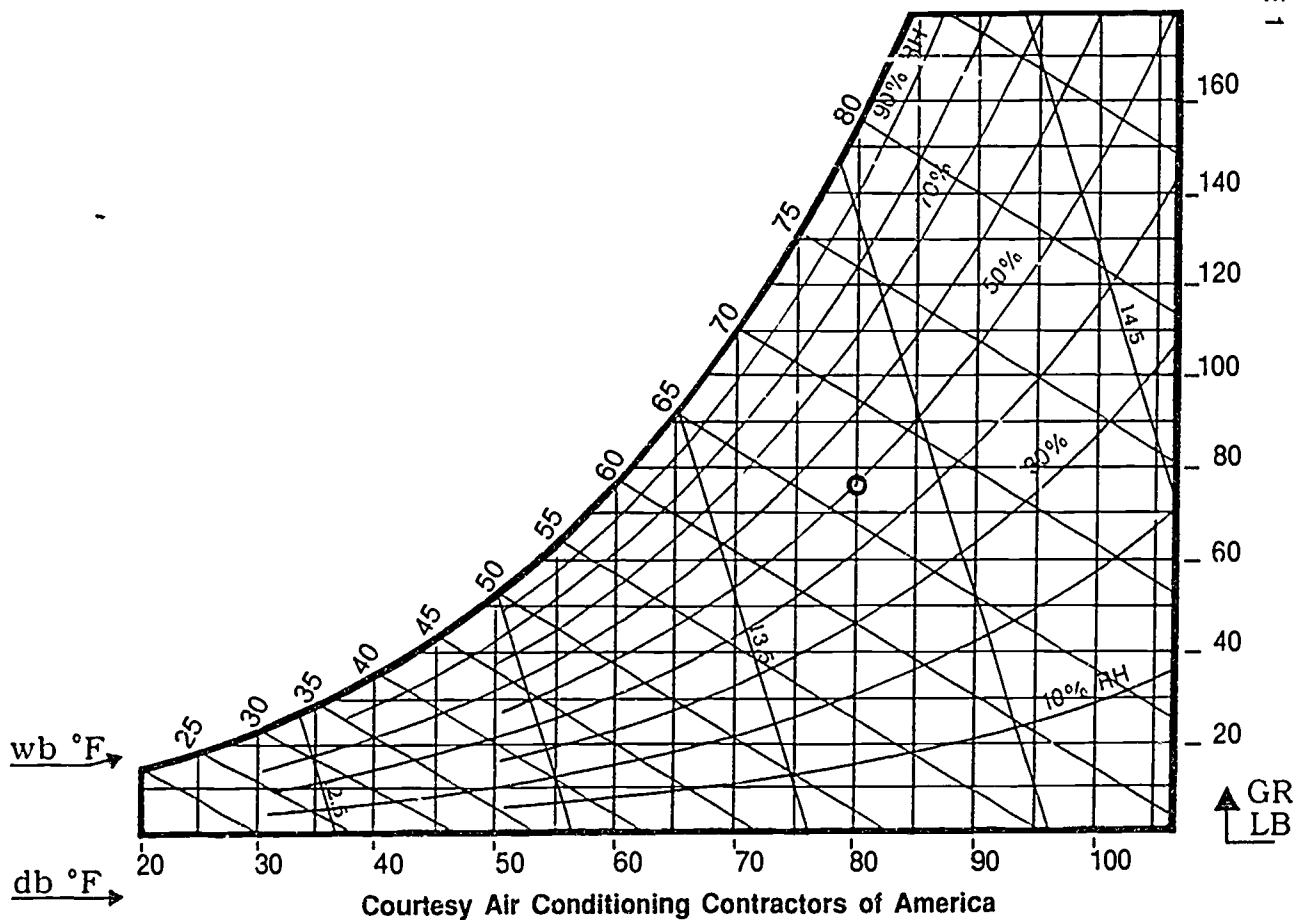

Courtesy Air Conditioning Contractors of America

**PSYCHROMETRICS FOR RESIDENTIAL HVAC
UNIT I**

**ASSIGNMENT SHEET #3 — DETERMINE HOW OUTSIDE AIR SHOULD
BE CONDITIONED TO PROVIDE A COMFORTABLE HUMIDITY AND
TEMPERATURE COMBINATION IN WINTER HEATING**

Directions: Assume that a winter heating situation is present with an outdoor dry-bulb temperature of 35°F and outdoor relative humidity of 25%, and that the indoor comfort conditions should be within the range of 30 to 35% relative humidity and a temperature range of 72 to 75°F.

Procedure:

1. On the psychrometric chart in Figure 1, place a mark where the 35°F dry-bulb temperature and a relative humidity of 25% intersect.
 2. Place a mark where the 75°F dry-bulb temperature and a relative humidity of 35% intersect.
 3. Use a ruler and pencil to draw a line between the marks in items 1 and 2.
 4. Relative humidity (increases) (decreases) and moisture must be (added to) (removed from) the air
 5. Dry-bulb temperature (increases) (decreases) and heat must be (added to) (removed from) the air.
- Have your instructor evaluate your calculations.

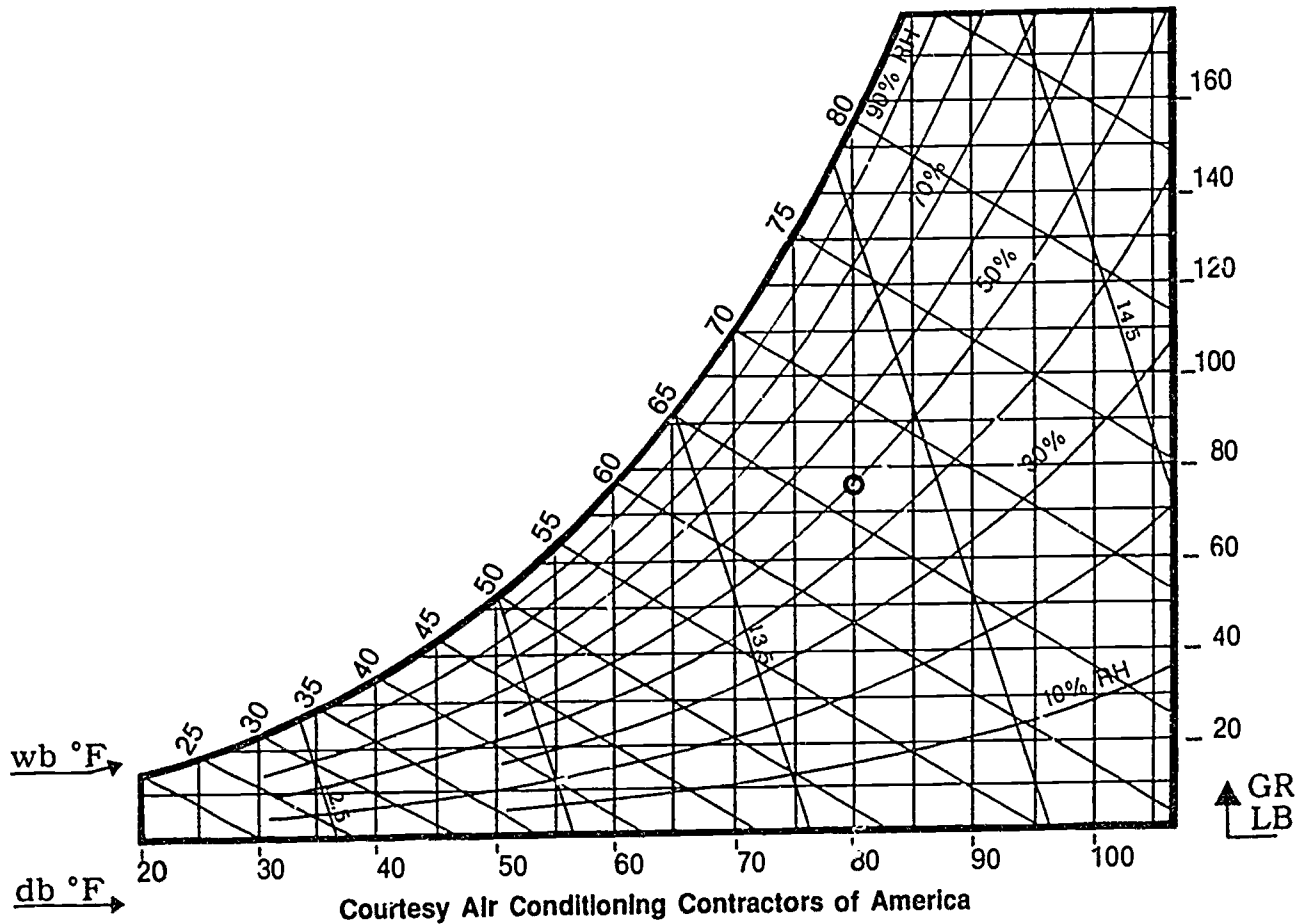

Courtesy Air Conditioning Contractors of America

FIGURE 1

ASSIGNMENT SHEET #3

**PSYCHROMETRICS FOR RESIDENTIAL HVAC
UNIT I**

**ASSIGNMENT SHEET #4 — DETERMINE HOW OUTSIDE AIR SHOULD
BE CONDITIONED TO PROVIDE A COMFORTABLE HUMIDITY AND
TEMPERATURE COMBINATION IN SUMMER COOLING**

Directions: Assume that a summer air condition situation is present with an outdoor dry-bulb temperature of 90°F and an outdoor relative humidity of 70%, and that the indoor comfort conditions should be within the range of 45 to 50% relative humidity and a temperature range of 75 to 78°F.

Procedure:

1. On the psychrometric chart in Figure 1, place a mark where the 90°F dry-bulb temperature and a relative humidity of 70% intersect.
 2. Place a mark where the 78°F dry-bulb temperature and a relative humidity of 50% intersect.
 3. Use a ruler and pencil to draw a line between the marks made in items 1 and 2.
 4. Relative humidity (increases) (decreases) and moisture must be (added to) (removed from) the air
 5. Dry-bulb temperature (increases) (decreases) and heat must be (added to) (removed from) the air.
- Have your instructor evaluate your calculations.

FIGURE 1

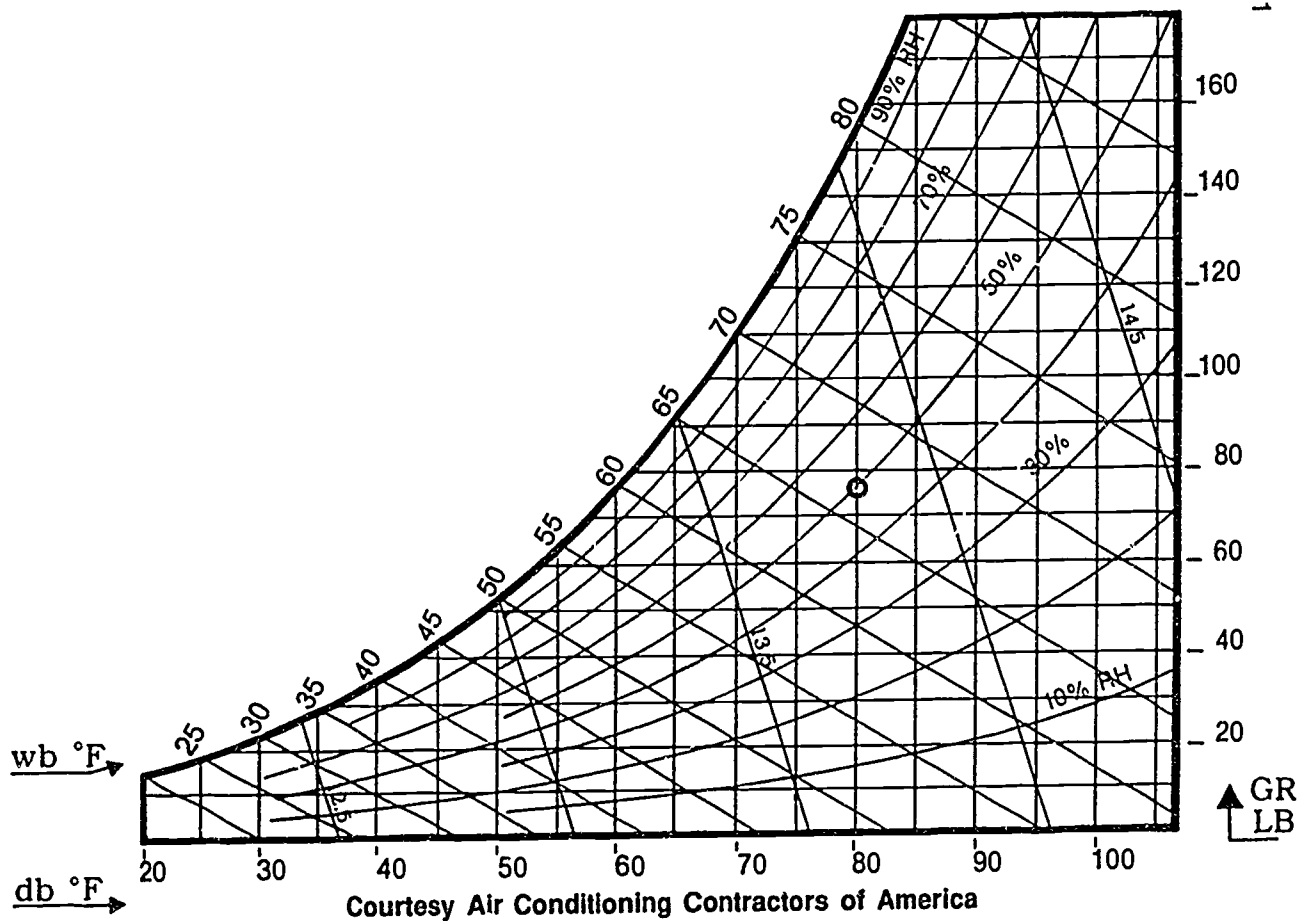

Courtesy Air Conditioning Contractors of America

**PSYCHROMETRICS FOR RESIDENTIAL HVAC
UNIT I**

ANSWERS TO ASSIGNMENT SHEETS

Assignment Sheet #1

3. 30%

Assignment Sheet #2

4. 50°F

Assignment Sheet #3

4. Relative humidity increases and moisture must be added to the air
5. Dry-bulb temperature increases and heat must be added to the air

Assignment Sheet #4

4. Relative humidity decreases and moisture must be removed from the air
5. Dry-bulb temperature decreases and heat must be removed from the air

**PSYCHROMETRICS FOR RESIDENTIAL HVAC
UNIT I**

**JOB SHEET #1 — DETERMINE THE RELATIVE HUMIDITY
OF A CONDITIONED SPACE**

- A. Tools and equipment
1. 1 sling psychrometer
 2. 1 psychrometric chart
 3. 1 clean cotton wick
 4. Distilled water
 5. Conditioned space as selected by instructor
- B. Procedure
1. Examine work space to make sure you have room to use a sling psychrometer.
 2. Saturate the wick thoroughly with distilled water.
 3. Whirl the psychrometer rapidly in the air for at least 30 seconds and take a reading.
 4. Whirl the psychrometer rapidly in the air for another 15 to 30 seconds and take a final reading.

(NOTE: When manufacturer's instructions for psychrometer operation are available, follow them carefully.)
 5. Enter dry-bulb and wet-bulb readings on the psychrometric chart that accompanies this job sheet.
 6. Record the relative humidity of the conditioned space.
 - Check with your instructor for accuracy of your reading.
 7. Clean and return psychrometer to proper storage area.

FIGURE 1

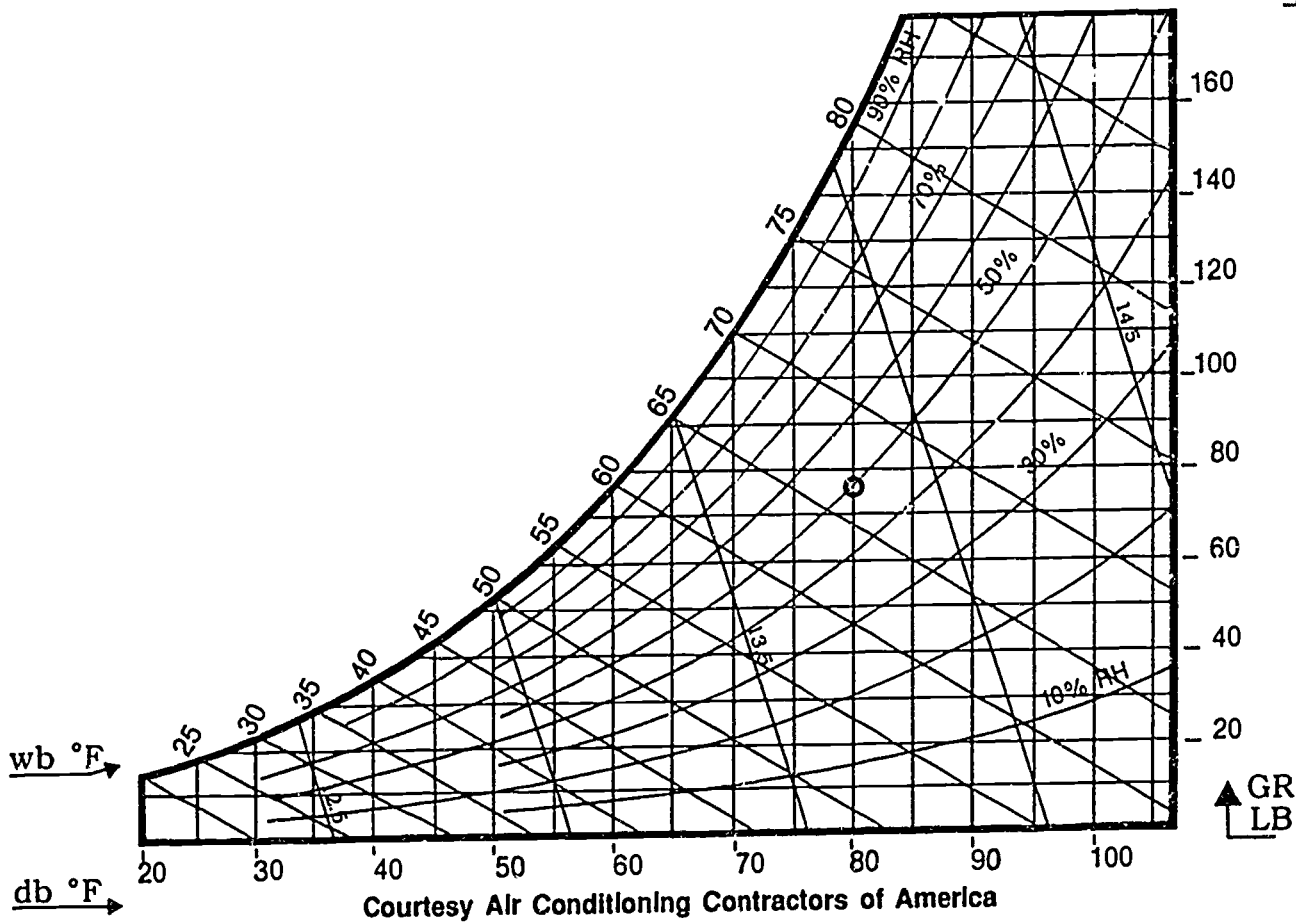

JOB SHEET #1

PSYCHROMETRICS FOR RESIDENTIAL HVAC
UNIT I

JOB SHEET #2 — DETERMINE THE RELATIVE HUMIDITY
OF AN OUTDOOR SPACE

A. Tools and equipment

1. 1 sling psychrometer
2. 1 psychrometric chart
3. 1 clean cotton wick
4. Distilled water
5. Outdoor space as selected by instructor

B. Procedure

1. Examine the area carefully to make sure there is nothing you will strike as you whirl the psychrometer.
2. Saturate the wick thoroughly with distilled water.
3. Whirl the psychrometer rapidly in the air for at least 30 seconds and take a reading.
4. Whirl the psychrometer rapidly in the air for another 15 to 30 seconds and take a final reading.

(NOTE: When manufacturer's instructions for psychrometer operation are available follow them carefully.)

5. Enter dry-bulb and wet-bulb readings on the psychrometric chart that accompanies this job sheet.
6. Record the relative humidity of the outdoor space.
- Check with your instructor for accuracy of your reading.
7. Clean and return psychrometer to proper storage area.

FIGURE 1

JOB SHEET #2

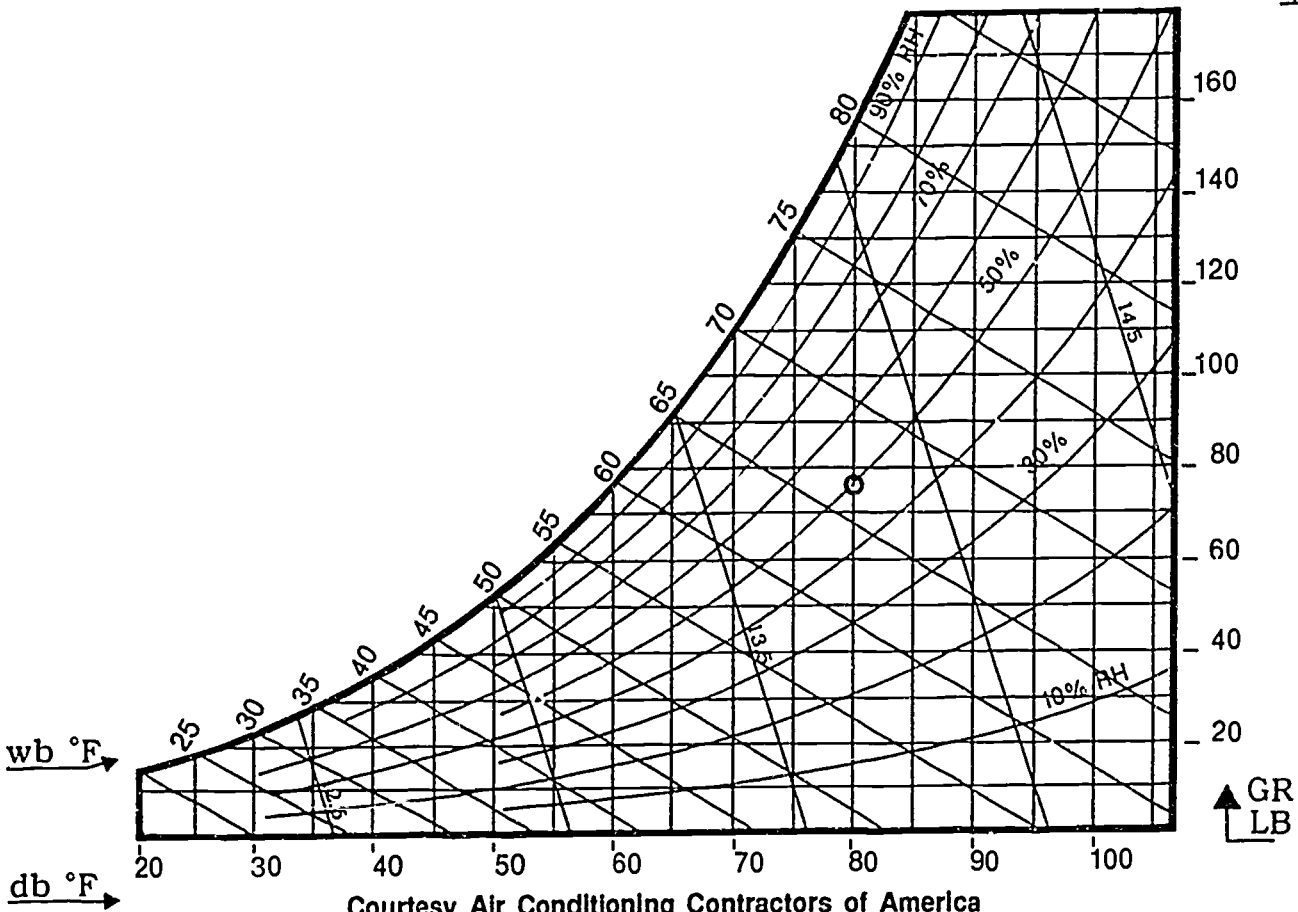

Courtesy Air Conditioning Contractors of America

**PSYCHROMETRICS FOR RESIDENTIAL HVAC
UNIT I**

**JOB SHEET #3 — DETERMINE THE WET-BULB TEMPERATURE
OF THE AIR INSIDE A DUCT**

A. Tools and equipment

1. 1 sling psychrometer
2. Distilled water
3. Awl
4. Left hand aviation snips
5. Duct tape
6. Duct as selected by instructor

B. Procedure

1. Properly prepare psychrometer.
2. Make initial opening in the duct with the awl.
3. Enlarge the opening with aviation snips until it is just large enough to facilitate the psychrometer.
4. Insert the psychrometer carefully.
5. Turn fan on and allow it to run until the wet-bulb reading reaches its maximum depression.
6. Record wet-bulb reading: _____.
7. Remove psychrometer and patch opening with duct tape.
- Check with instructor for accuracy of your reading.
8. Clean psychrometer and return to proper storage area.

**PSYCHROMETRICS FOR RESIDENTIAL HVAC
UNIT I**

**PRACTICAL TEST #1
JOB SHEET #1 — DETERMINE THE RELATIVE HUMIDITY
OF A CONDITIONED SPACE**

Student's name _____ Date _____

Evaluator's name _____ Attempt no. _____

Student instructions: When you are ready to perform this task, ask you instructor to observe the procedure and complete this form. All items listed under "Process Evaluation" must receive a "yes" for you to receive an overall performance evaluation.

PROCESS EVALUATION

(EVALUATOR NOTE: Place a check mark in the "Yes" or "No" blanks to designate whether or not the student has satisfactorily achieved each step in this procedure. If the student is unable to achieve this competency, have the student review the materials and try again.)

The student:	YES	NO
1. Verified a safe work area.	<input type="checkbox"/>	<input type="checkbox"/>
2. Saturated wick with distilled water.	<input type="checkbox"/>	<input type="checkbox"/>
3. Whirled psychrometer and took an initial reading.	<input type="checkbox"/>	<input type="checkbox"/>
4. Whirled psychrometer and took second reading.	<input type="checkbox"/>	<input type="checkbox"/>
5. Used psychrometric chart to enter wet-bulb and dry-bulb readings.	<input type="checkbox"/>	<input type="checkbox"/>
6. Determined relative humidity of conditioned space.	<input type="checkbox"/>	<input type="checkbox"/>
7. Secured area and returned equipment.	<input type="checkbox"/>	<input type="checkbox"/>

Evaluator's comments: _____

JOB SHEET #1 PRACTICAL TEST

PRODUCT EVALUATION

(EVALUATOR NOTE. Rate the student on the following criteria by circling the appropriate numbers. Each item must be rated at least a "3" for mastery to be demonstrated. (See performance evaluation key below.) If the student is unable to demonstrate mastery, student materials should be reviewed and another test procedure must be submitted for evaluation.)

 Criteria:

Safe work area verification	4	3	2	1
Psychrometer preparation	4	3	2	1
Psychrometer use	4	3	2	1
Relative humidity calculation	4	3	2	1

 EVALUATOR'S COMMENTS: _____

PERFORMANCE EVALUATION KEY
4 — Skilled — Can perform job with no additional training. 3 — Moderately skilled — Has performed job during training program; limited additional training may be required. 2 — Limited skill — Has performed job during training program; additional training is required to develop skill. 1 — Unskilled — Is familiar with process, but is unable to perform job.

(EVALUATOR NOTE. If an average score is needed to coincide with a competency profile, total the designated points in "Product Evaluation" and divide by the total number of criteria.)

**PSYCHROMETRICS FOR RESIDENTIAL HVAC
UNIT I**

**PRACTICAL TEST #2
JOB SHEET #2 — DETERMINE THE RELATIVE HUMIDITY
OF AN OUTDOOR SPACE**

Student's name _____ Date _____

Evaluator's name _____ Attempt no. _____

Student instructions: When you are ready to perform this task, ask your instructor to observe the procedure and complete this form. All items listed under "Process Evaluation" must receive a "yes" for you to receive an overall performance evaluation.

PROCESS EVALUATION

(EVALUATOR NOTE: Place a check mark in the "Yes" or "No" blanks to designate whether or not the student has satisfactorily achieved each step in this procedure. If the student is unable to achieve this competency, have the student review the materials and try again.)

The student:	YES	NO
1. Verified safe work area.	<input type="checkbox"/>	<input type="checkbox"/>
2. Saturated wick with distilled water.	<input type="checkbox"/>	<input type="checkbox"/>
3. Whirled psychrometer and took an initial reading.	<input type="checkbox"/>	<input type="checkbox"/>
4. Whirled psychrometer and took a second reading.	<input type="checkbox"/>	<input type="checkbox"/>
5. Used psychrometric chart to enter wet-bulb and dry-bulb readings.	<input type="checkbox"/>	<input type="checkbox"/>
6. Determined relative humidity of an outdoor space.	<input type="checkbox"/>	<input type="checkbox"/>
7. Secured area and returned equipment.	<input type="checkbox"/>	<input type="checkbox"/>

Evaluator's comments: _____

JOB SHEET #2 PRACTICAL TEST

PRODUCT EVALUATION

(EVALUATOR NOTE: Rate the student on the following criteria by circling the appropriate numbers. Each item must be rated at least a "3" for mastery to be demonstrated. (See performance evaluation key below.) If the student is unable to demonstrate mastery, student materials should be reviewed and another test procedure must be submitted for evaluation.)

Criteria:

Safe work area verification	4	3	2	1
Psychrometer preparation	4	3	2	1
Psychrometer use	4	3	2	1
Relative humidity calculation	4	3	2	1

EVALUATOR'S COMMENTS: _____

PERFORMANCE EVALUATION KEY

- 4 — **Skilled** — Can perform job with no additional training.
- 3 — **Moderately skilled** — Has performed job during training program; limited additional training may be required.
- 2 — **Limited skill** — Has performed job during training program; additional training is required to develop skill.
- 1 — **Unskilled** — Is familiar with process, but is unable to perform job.

(EVALUATOR NOTE. If an average score is needed to coincide with a competency profile, total the designated points in "Product Evaluation" and divide by the total number of criteria.)

**PSYCHROMETRICS FOR RESIDENTIAL HVAC
UNIT I**

**PRACTICAL TEST #3
JOB SHEET #3 — DETERMINE THE RELATIVE HUMIDITY
OF AN OUTDOOR SPACE**

Student's name _____ Date _____

Evaluator's name _____ Attempt no. _____

Student instructions: When you are ready to perform this task, ask you instructor to observe the procedure and complete this form. All items listed under "Process Evaluation" must receive a "yes" for you to receive an overall performance evaluation.

PROCESS EVALUATION

(EVALUATOR NOTE: Place a check mark in the "Yes" or "No" blanks to designate whether or not the student has satisfactorily achieved each step in this procedure. If the student is unable to achieve this competency, have the student review the materials and try again.)

The student:	YES	NO
1. Prepared psychrometer.	<input type="checkbox"/>	<input type="checkbox"/>
2. Opened duct safely with an awl.	<input type="checkbox"/>	<input type="checkbox"/>
3. Enlarged opening and inserted psychrometer safely.	<input type="checkbox"/>	<input type="checkbox"/>
4. Turned fan on and waited for maximum wet-bulb reading.	<input type="checkbox"/>	<input type="checkbox"/>
5. Entered wet-bulb reading.	<input type="checkbox"/>	<input type="checkbox"/>
6. Removed psychrometer and patched duct.	<input type="checkbox"/>	<input type="checkbox"/>
7. Check accuracy of wet-bulb reading.	<input type="checkbox"/>	<input type="checkbox"/>
8. Secured area and returned equipment.	<input type="checkbox"/>	<input type="checkbox"/>

Evaluator's comments: _____

JOB SHEET #3 PRACTICAL TEST

PRODUCT EVALUATION

(EVALUATOR NOTE. Rate the student on the following criteria by circling the appropriate numbers. Each item must be rated at least a "3" for mastery to be demonstrated. (See performance evaluation key below.) If the student is unable to demonstrate mastery, student materials should be reviewed and another test procedure must be submitted for evaluation.)

 Criteria:

Safe work area verification	4	3	2	1
Psychrometer preparation	4	3	2	1
Psychrometer use	4	3	2	1
Wet-bulb reacting verification	4	3	2	1

 EVALUATOR'S COMMENTS: _____

PERFORMANCE EVALUATION KEY
4 — Skilled — Can perform job with no additional training. 3 — Moderately skilled — Has performed job during training program; limited additional training may be required. 2 — Limited skill — Has performed job during training program; additional training is required to develop skill. 1 — Unskilled — Is familiar with process, but is unable to perform job.

(EVALUATOR NOTE. If an average score is needed to coincide with a competency profile, total the designated points in "Product Evaluation" and divide by the total number of criteria.)

**PSYCHROMETRICS FOR RESIDENTIAL HVAC
UNIT I**

TEST

Name _____ Score _____

1. Match the terms on the right with their correct definitions.

- | | | | |
|----------|---|-----|----------------------|
| _____ a. | The science of measuring and changing the properties of air | 1. | Air dew point |
| _____ b. | The air temperature as measured by an ordinary thermometer | 2. | Sensible cooling |
| _____ c. | The air temperature as measured by a thermometer whose bulb is covered with a wet wick and moved in air at a velocity of one thousand feet per minute | 3. | Latent heat |
| _____ d. | The percentage of moisture in the air compared to the total amount of moisture the air could hold at the same temperature and barometric pressure | 4. | Dry-bulb temperature |
| _____ e. | The temperature at which moisture condenses as liquid on a surface | 5. | Enthalpy |
| _____ f. | The addition of heat in a situation where moisture content increases but air temperature does not change | 6. | Psychrometrics |
| _____ g. | The removal of heat in a situation where moisture content decreases but air temperature does not change | 7. | Latent cooling |
| _____ h. | The addition of heat in a situation where air temperature increases but moisture content does not change | 8. | Relative humidity |
| _____ i. | The removal of heat in a situation where air temperature decreases but moisture content does not change | 9. | Sensible heat factor |
| _____ j. | The relationship of sensible heat to total heat | 10. | Sensible heat |
| _____ k. | The total sensible and latent heat in air as measured in Btu's per pound of dry air | 11. | Wet-bulb temperature |
| _____ l. | A visual summary of the properties of air, including or relating to temperature, moisture content, density, and heat content | 12. | Specific humidity |
| | | 13. | Psychrometric chart |

TEST

2. Select true statements concerning basic information found on a psychrometric chart by placing an "X" beside each true statement.

- ___ a. Dry-bulb temperature
- ___ b. Dry-bulb depression
- ___ c. Wet-bulb temperature
- ___ d. Boiling point of water
- ___ e. Dew point temperature
- ___ f. Potential heat
- ___ g. Relative humidity

3. Complete the following psychrometric chart to show the location of dry-bulb temperature readings.

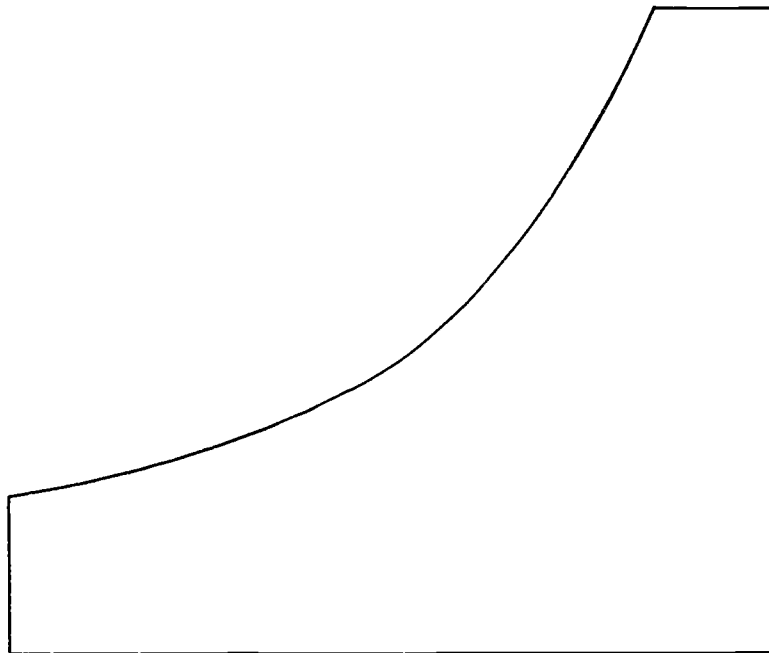

TEST

4. Complete the following psychrometric chart to show the location of wet-bulb temperature readings.

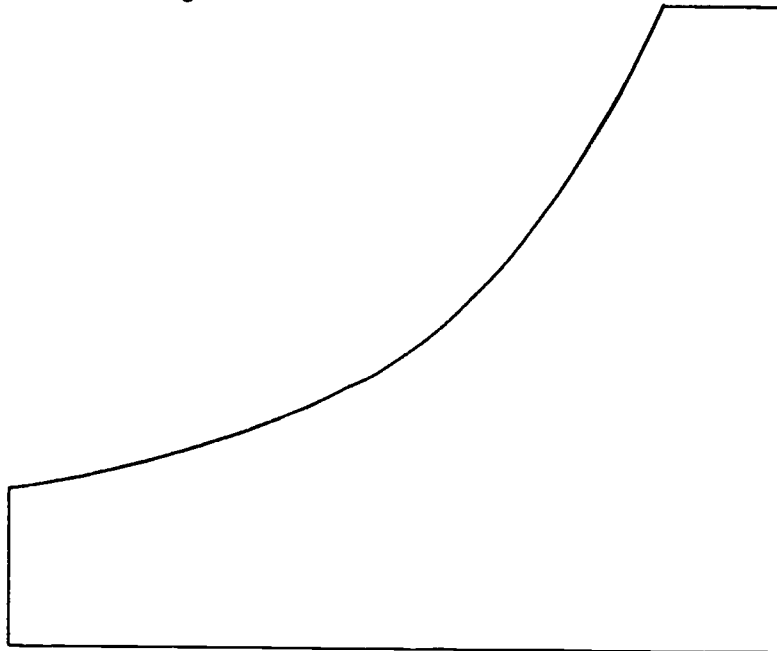

5. Complete the following psychrometric chart to show the location of dew point temperature readings.

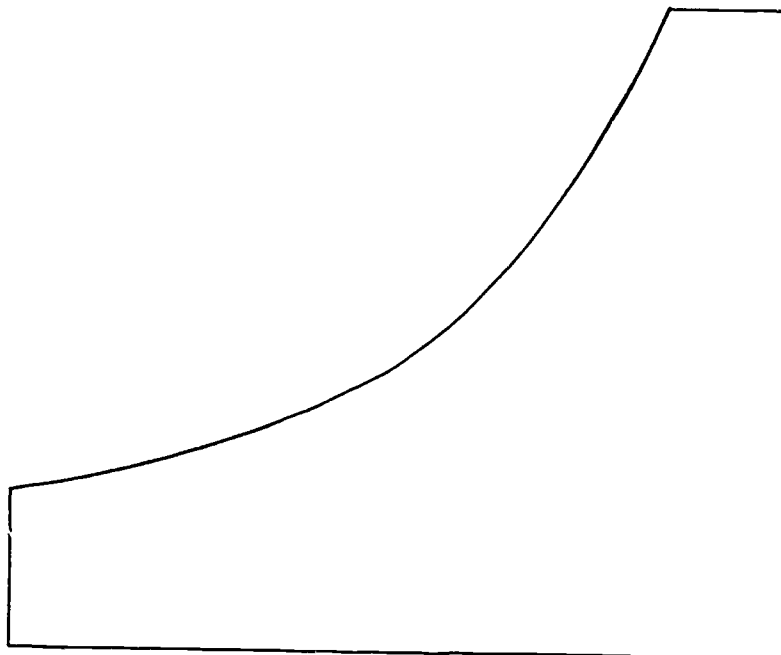

TEST

6. Complete the following psychrometric chart to show the location of relative humidity readings.

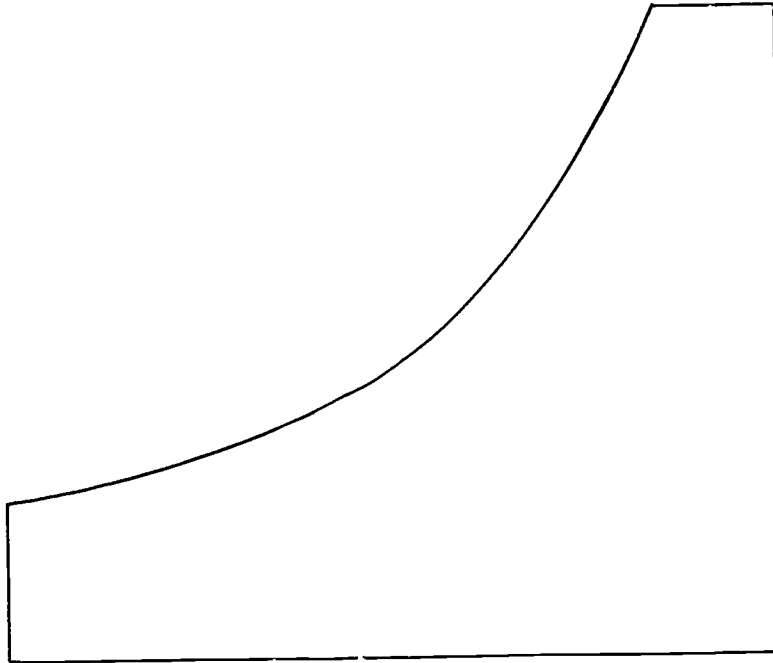

7. Complete statements concerning three basic cumulative psychrometric processes by circling the material that best completes each of the following statements.
- Cooling and (heating) (humidifying)
 - Cooling and (dehumidifying) ((sensible heat)
 - Heating and (humidifying) (dehumidifying)
8. Select true statements concerning typical air-conditioning processes that can be shown on a psychrometric chart. Place an "X" beside each true statement.
- a. That outdoor air subtracts heat and moisture when it is mixed with indoor air
 - b. That heat and moisture are removed as they pass through the air-conditioning apparatus
 - c. That an air mixture of correct temperature and humidity can be determined to maintain a comfort zone in a given area

TEST

9. Complete statements concerning sling psychrometers by circling the materials that best completes each statement.
- Sling psychrometers are devices with (extended) (dual) thermometers and are used to measure (dry-bulb and wet-bulb) (inside and outside) temperatures at the same time.
 - Two standard thermometers are mounted side by side on a sling psychrometer, but one of them is covered with a wet wick that should be saturated with (distilled water) (rubbing alcohol) before it is used.
 - The handle of a sling psychrometer is used to whirl the device rapidly around in the air, fast enough to duplicate a speed of (one thousand feet per second) (one thousand feet per minute) in order to get an accurate wet-bulb reading.
10. Solve the following problems by selecting the best solution to the problem presented.
- Another technician you're working with starts to wet the sock on a sling psychrometer with tap water. You should:
 - Let the technician continue.
 - Recommend the use of distilled water.
 - Recommend the use of rubbing alcohol.
 - A technician friend has just recorded an initial reading with a sling psychrometer and starts to put the device away. You should:
 - Let the technician put the device away.
 - Check the initial reading yourself.
 - Suggest the need for a second reading to verify accuracy.
 - If a sling psychrometer is so equipped, the fastest way to get a relative humidity reading is to:
 - Plot it on a psychrometric chart.
 - Use the dry-bulb and wet-bulb scales on the psychrometer.
 - Make an intelligent guess.

(NOTE: If the following activities have not been accomplished prior to the test, ask you instructor when they should be completed.)

- Determine relative humidity when only dry-bulb and wet-bulb temperatures are known. (Assignment Sheet #1)
- Determine dew point when only dry-bulb and wet-bulb temperatures are known. (Assignment Sheet #2)
- Determine how outside air should be conditioned to provide a comfortable humidity and temperature combination in winter heating. (Assignment Sheet #3)

TEST

14. Determine how outside air should be conditioned to provide a comfortable humidity and temperature combination in summer cooling. (Assignment Sheet #4)
15. Demonstrate the ability to:
 - a. Determine the relative humidity of a conditioned space. (Job Sheet #1)
 - b. Determine the relative humidity of an outdoor space. (Job Sheet #2)
 - c. Determine the wet-bulb temperature of the air inside a duct. (Job Sheet #3)

**PSYCHROMETRICS FOR RESIDENTIAL HVAC
UNIT I**

ANSWERS TO TEST

1.

a. 6	e. 1	i. 2
b. 4	f. 3	j. 9
c. 11	g. 7	k. 5
d. 8	h. 10	l. 13

2. a, c, e, g

3. Chart should show:
 - a. The degree reading is represented by a vertical line
 - b. Degree readings advance from left to right in units of 5 degrees on a straight horizontal line at the bottom of the chart

4. Chart should show:
 - a. The degree reading is represented by a diagonal line
 - b. Degree readings advance from lower left to upper middle in units of 5 degrees on a curved line

5. Chart should show:
 - a. The degree reading is represented by a horizontal line
 - b. Degree readings advance from lower left to upper middle in units of 5 degrees on a curved line

6. Chart should show:
 - a. Percentages are expressed in units of ten ranging from 0 to 100
 - b. Percentage readings advance from bottom left to lower and upper right on curved lines
 - c. Relative humidity is read at the point of intersection of the dry-bulb and wet-bulb lines

7.
 - a. Humidifying
 - b. Dehumidifying
 - c. Humidifying

8. b, c

ANSWERS TO TEST

9.
 - a. Dual dry-bulb and wet-bulb
 - b. Distilled water
 - c. One thousand feet per minute

10.
 - a. 2
 - b. 3
 - c. 2

11. Evaluated to the satisfaction of the instructor

12. Evaluated to the satisfaction of the instructor

13. Evaluated to the satisfaction of the instructor

14. Evaluated to the satisfaction of the instructor

15.
 - a. Evaluated according to criteria in Practical Test #1
 - b. Evaluated according to criteria in Practical Test #2
 - c. Evaluated according to criteria in Practical Test #3

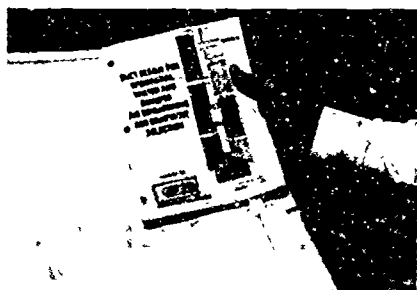

RESIDENTIAL LOAD CALCULATIONS UNIT II

UNIT OBJECTIVE

After completion of this unit, the student should be able to calculate heat loss and heat gain for a specific structure in a given geographical location. These competencies will be demonstrated by completing the assignment sheets and by scoring a minimum of 85 percent on the written test.

SPECIFIC OBJECTIVES

After completion of this unit, the student should be able to:

1. Match terms related to residential load calculations with their definitions.
2. Select true statements concerning the value of standardized load calculations.
3. Complete statements concerning factors in determining heat loss and heat gain.
4. Select true statements concerning the steps in calculating heat transfer multipliers.
5. Select true statements concerning factors to consider when sizing heating equipment.
6. Select true statements concerning factors to consider when sizing cooling equipment.
7. Complete statements concerning ways structural modifications can affect equipment selection.
8. Calculate heat loss and heat gain for a residence using "entire house" for a quick calculation. (Assignment Sheet #1)
9. Determine shaded and unshaded glass areas for use in heat gain calculations. (Assignment Sheet #2)
10. Calculate heat loss for a residence, room by room. (Assignment Sheet #3)
11. Calculate the heat gain for a residence, room by room. (Assignment Sheet #4)

RESIDENTIAL LOAD CALCULATIONS UNIT II

SUGGESTED ACTIVITIES

- A. Obtain additional materials and/or invite resource people to class to supplement/reinforce information provided in this unit of instruction.

(NOTE: This activity should be completed prior to the teaching of this unit.)

- B. Make transparencies from the transparency masters included with this unit.
- C. Provide students with objective sheet.
- D. Discuss unit and specific objectives.
- E. Provide students with information and assignment sheets.

- F. Discuss information and assignment sheets.

(NOTE: Use the transparencies to enhance the information as needed.)

- G. Provide students with job sheets.
- H. Discuss and demonstrate the procedures outlined in the job sheets.
- I. Make sure each student has a J-Sheet (Form J-1 Worksheet) for use with the assignment sheets.

- J. Integrate the following activities throughout the teaching of this unit:

1. Review heating and cooling load calculations from *Manual J*, and show students how to use the J-sheet to record the vital measurements for making proper calculations.
2. Invite a representative from a local utility company to talk to the class about computer load calculations, or use RIGHT-J from ACCA to demonstrate how heating and cooling loads can be quickly estimated on a computer. Check Suggested Supplemental Material for RIGHT-J information.
3. Take a field trip and have students measure and calculate a residence using the "Quick Estimate" procedure.
4. Meet individually with students to evaluate their progress through this unit of instruction, and indicate to them possible areas for improvement.

- K. Give test.

- L. Evaluate test.

- M. Reteach if necessary.

SUGGESTED ACTIVITIES

REFERENCES USED IN WRITING THIS UNIT

- A. Eckes, William, and Dan Fulkerson. *Air Conditioning and Refrigeration Book Three*. Stillwater, OK 74074: Mid-America Vocational Curriculum Consortium, 1981.
- B. Rutkowski, Hank. *Manual J Load Calculation for Residential Winter and Summer Air Conditioning*. (Seventh edition.) Washington, DC 20036: Air Conditioning Contractors of America, 1986.

SUGGESTED SUPPLEMENTAL MATERIAL

- A. *Manual J*.
- B. Form J-1 Worksheet (J-Sheet).

(NOTE. Both Manual J and the J-Sheet are available from The Air Conditioning Contractors of America, 1513 16th Street NW, Washington, DC 20036.)

- C. RIGHT-J is computer software designed especially for ACCA's Seventh Edition of *Manual J*. RIGHT-J is for IBM or IBM compatible computers and is available for both 5¼" or 3½" floppy disk drives. The software can be used as a whole house estimator or a detailed room-by-room analyzer. To order, or for information, call ACCA at 202-483-9370 or write to ACCA, 1513 16th Street NW, Washington, DC 20036.

(NOTE: RIGHT-D for duct estimating is also available from ACCA.)

**RESIDENTIAL LOAD CALCULATIONS
UNIT II****INFORMATION SHEET****I. Terms and definitions**

- A. **Btu (British thermal unit)** — The amount of heat required to raise the temperature of one pound of water one degree Fahrenheit
- B. **Btuh (British thermal units per hour)** — The unit used to express hourly heat flow
- C. **Heat transfer** — The movement of heat from one substance or region to another
- D. **HTM (Heat Transfer Multiplier)** — An index of heat transfer through one square foot of a structural component at specific design conditions
- E. **R-value** — The rating given to a material's ability to resist heat transfer
- F. **U-value** — A heat transmission coefficient arrived at by adding the total resistance of a component to the effects of convection on the inside and outside surfaces of the component and then dividing one by the figure to get the reciprocal

Example: If the R values and surface resistance values totaled 13.82, then 1.0 divided by 13.82 would result in a U value of 0.072 Btu/(hr.sq.ft.°F).

- G. **Gross exposed walls** — The total square footage, including doors and windows, of walls exposed to the outside
- H. **Net exposed walls** — The total square footage, excluding doors and windows, of walls exposed to the outside
- I. **Exposed partition** — A wall separating a conditioned space from an unconditioned space (Transparency 1)
- J. **Knee walls** — Walls of upper rooms exposed to attic temperatures (Transparency 1)
- K. **Internal heat gain** — Sensible heat gain produced by people and appliances
- L. **Duct loss and duct gain** — Heating and cooling lost or gained because of air leakage and heat transfer in ducts
- M. **Ventilation** — Controlled air brought into a structure
- N. **Infiltration** — Uncontrolled air that leaks into a structure

INFORMATION SHEET

- O. **Cfm** — Cubic feet per minute
- P. **Ton of refrigeration** — A refrigerating effect equal to 12,000 Btuh
- Q. **Latent load** — The load associated with the amount of moisture a structure gains or loses from infiltration, ventilation, or from people and machines

II. The value of standardized load calculations

- A. Charts and tables in most load estimating forms reflect years of cumulative technical information through which the air conditioning industry has improved and simplified the load calculation process.
- B. Residential heating and cooling load estimates can be calculated from technically correct charts and tables that can be easily understood and readily applied.

(NOTE: Almost all manufacturers of heating and cooling equipment publish materials for load estimating, but because it reflects a standard in the industry and because of its acceptance by FHA, *Manual J* and its accompanying "Form J-1 Worksheet," have been selected to supplement the objectives and assignment sheets in this unit of instruction, and items from *Manual J* and the "Form J-1 Worksheet" which appear in this unit are reprinted with permission of the Air Conditioning Contractors of America.)

III. Factors in determining heat loss and heat gain

- A. Size of structure, the insulating qualities of its components, and orientation
(NOTE: Floor plans and specifications usually provide this information.)
- B. Outside design temperature for heat loss and gain
- C. Daily temperature range for heat gain
- D. Inside design temperature
- E. Design temperature difference for heat loss and heat gain
- F. HTM heating or HTM cooling

(NOTE: For basement walls 2' or more below grade will have a construction number from 15A through 15D or 15E through 15H, but if part of the basement is above grade, that part should use a construction number from 14A through 14F. Any part of the structure above grade must be included as part of the volume of the house, and a basement floor area that is in a heated space must be counted as part of the total floor area. Reference Table 2 on page 69 of ACCA's *Manual J*.)

INFORMATION SHEET

IV. Steps in calculating heat transfer multipliers

- A. Determine the R-value of the construction component.

(NOTE. For R-values of common building materials see Table 10 of *Manual J*.)

- B. Determine the U-value of the construction component.

(NOTE. In cases where a construction component consists of more than one element, the total R-value must be determined, then 1 divided by the total of the R-values results in the U-value.)

- C. Determine the HTM for heating by multiplying the U-value by the design temperature difference.

Example: A component with a U-value of .08 in a situation where the design temperature difference is 65°F would have an HTM (heating) of 5.2.

- D. Determine the HTM for cooling by multiplying the U-value by the equivalent temperature difference value from Figure 7-4 in Manual J.

Example: A wood frame wall component with a U-value of .08 where the design temperature is 95°F in a situation where the daily temperature range is high would have an HTM (cooling) of 1.5.

V. Factors to consider when sizing heating equipment (Transparency 2)

- A. Type of structure
B. Heat loss determined from design conditions
C. Temperature rise

(NOTE: A heating unit must have an air handling capacity capable of producing an air temperature rise within an approved range; most units list the approved range on the rating plate and the information can also be found in the manufacturer's specifications. If cooling is added the blower must be able to deliver the required CFM for cooling.)

- D. Static Pressure

(NOTE: Heating systems must overcome the resistance from supply and return ducts and other components that contribute to resistance or static pressure.)

INFORMATION SHEET

- E. Output capacity should never be less than the estimated heating load or less than specified by local codes.

(NOTE: Fossil fuel furnaces should provide 100% of heating load requirements plus any margin that occurs because of product line capacity increments, or more than specified by local codes.)

- F. System design should be compatible with cooling load and projected cooling equipment.

VI. Factors to consider when sizing cooling equipment (Transparency 3)

- A. Type of structure
- B. System design should be compatible with heating load and projected heating equipment.
- C. Heat gain determined from design conditions
- D. Cfm correctly related to humidity control

(NOTE: When air volume is decreased to remove more moisture from the air, it affects the capacity of the cooling unit.)

- E. Sensible capacity should not be less than the calculated sensible load or less than specified by local codes.
- F. Sensible capacity should not be more than 15 percent above the calculated sensible cooling load or more than specified by local codes.
- G. Latent capacity of the equipment should not be less than the calculated latent load.

VII. Ways structural modifications affect equipment selection

- A. When equipment will facilitate the cooling load, but not the heating load:
1. Increase the amount of insulation in walls and over ceilings.
 2. Install double pane storm windows.
 3. Weatherstrip doors and windows.
- B. When equipment will facilitate the heating load, but not the cooling load:
1. Shade windows with drapes, shades, solar screens, roof overhangs and awnings.
 2. Select light outside colors, especially for roofs.
 3. Increase the amount of insulation in walls and over ceilings.

INFORMATION SHEET

- C. Structural modifications can improve the compatibility of heating and cooling equipment.
- D. Structural modifications can: conserve vital energy.

Walls and Partitions

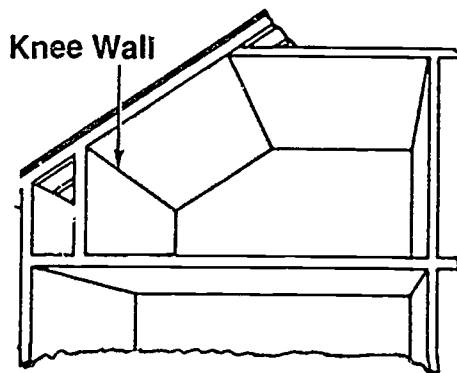
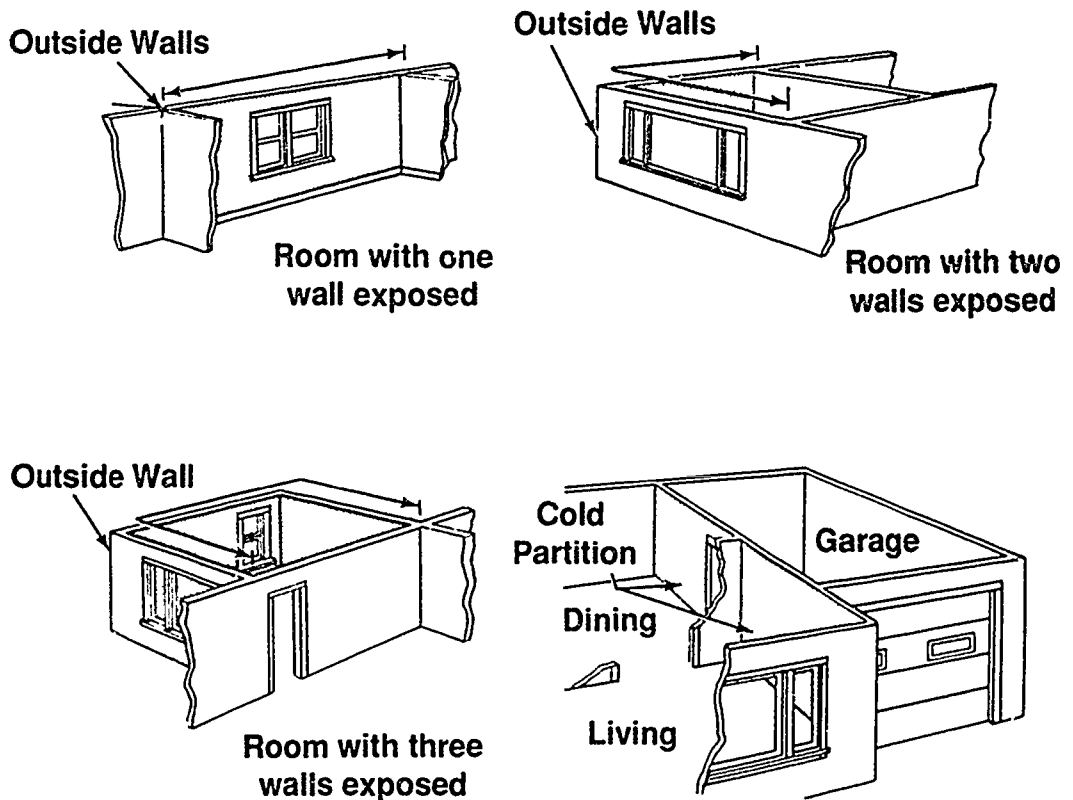

Courtesy Air Conditioning Contractors of America

Winter Heating Loads

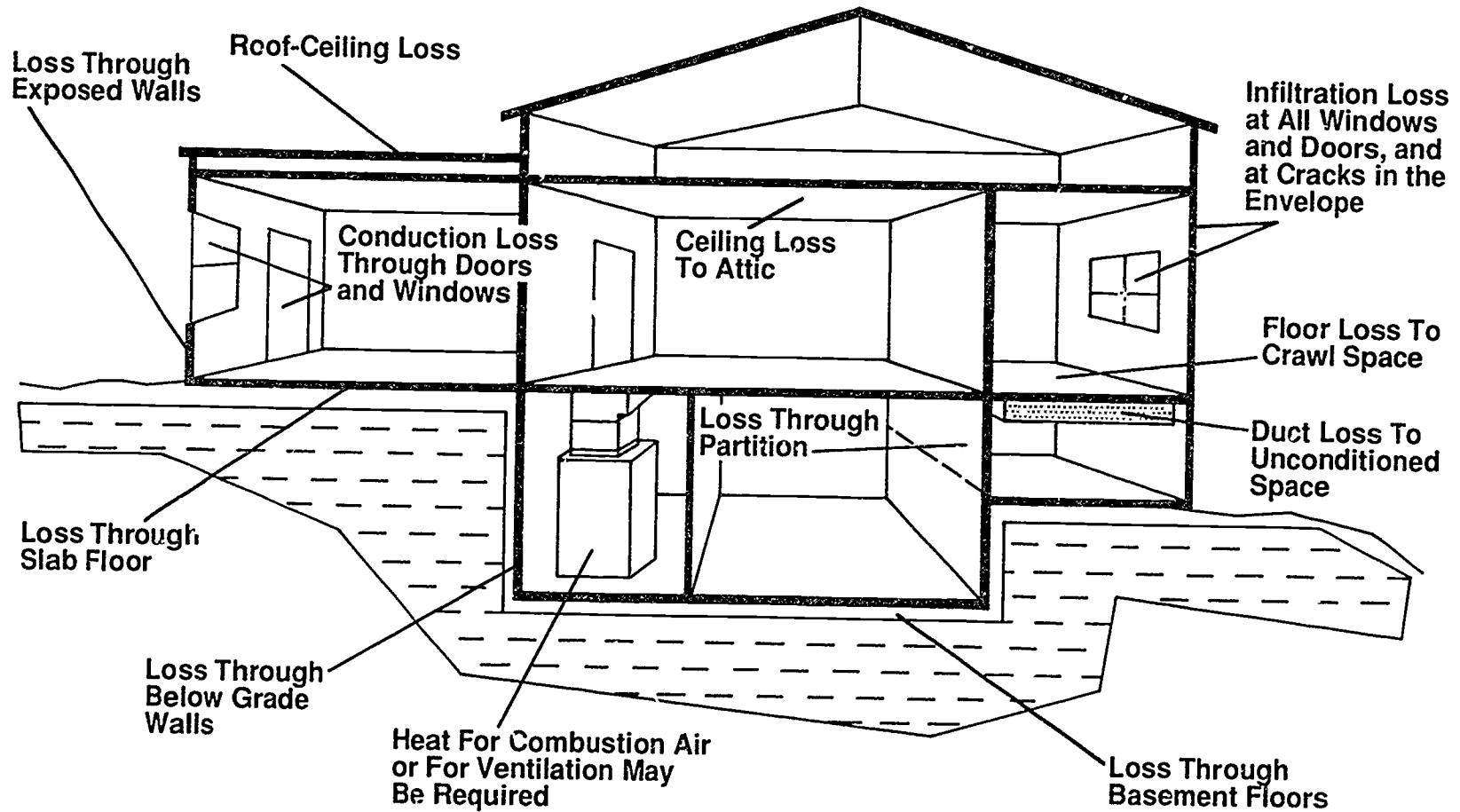

Summer Cooling Loads

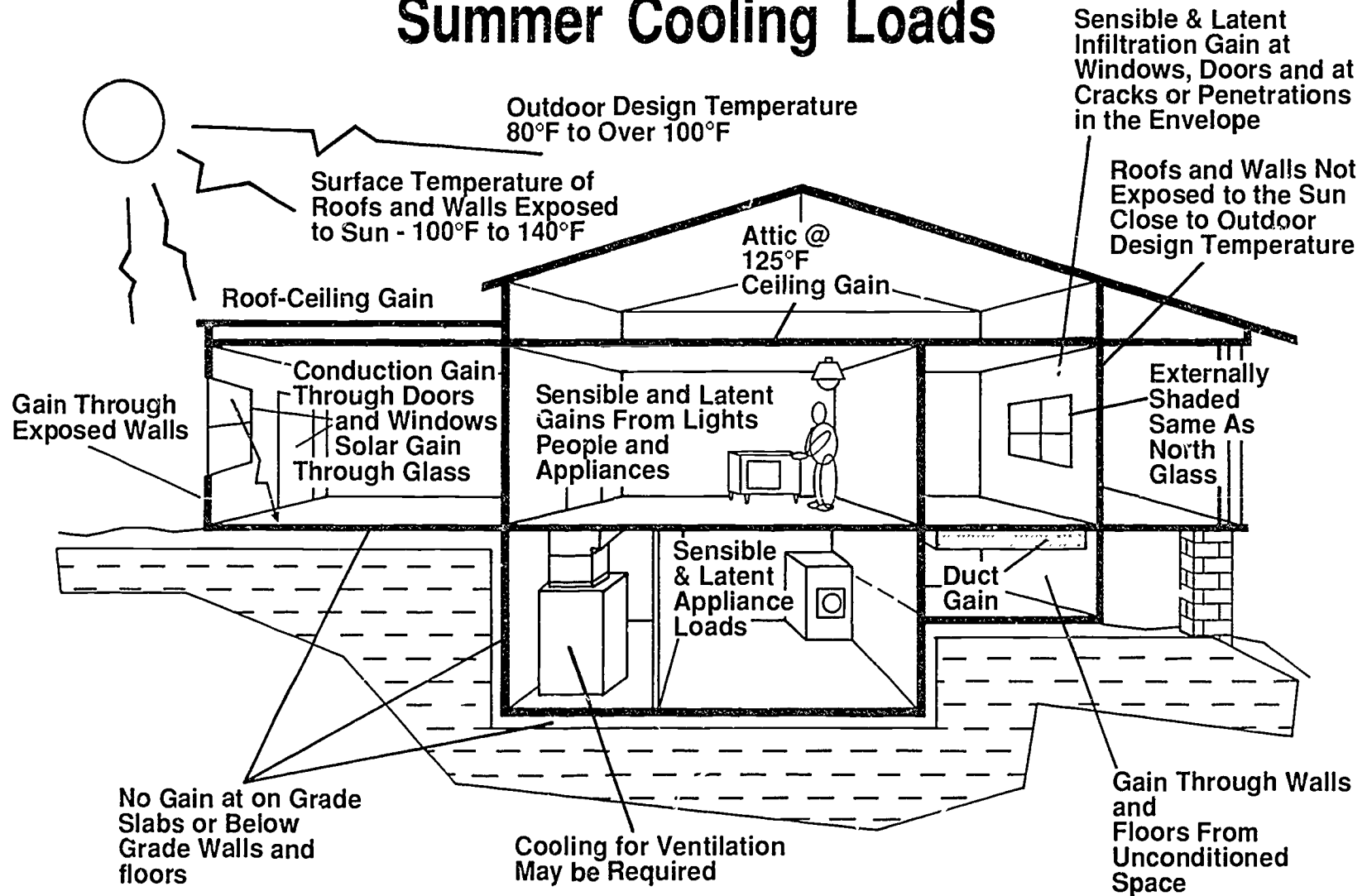

Courtesy Air Conditioning Contractors of America

RESIDENTIAL LOAD CALCULATIONS UNIT II

ASSIGNMENT SHEET #1 — CALCULATE HEAT LOSS AND HEAT GAIN OF A RESIDENCE USING "ENTIRE HOUSE" FOR A QUICK CALCULATION

Directions: Your supervisor has assigned you the job of determining the capacity of the furnace and cooling unit for a residence the company is bidding on. The floor plan and specifications are shown in Figure 1. Using tables in Manual J, and a J-sheet, calculate the heat loss and heat gain using the entire house column.

Procedure: Use the "Entire House" column in Form J-1 which will be referred to as the J-Sheet.

1. Complete winter and summer design conditions on the front of the J-Sheet from table 1 in Manual J. (See Figure 1)
2. Fill in the construction data on the J-Sheet from specifications of the residence to be calculated.
3. Enter the running feet of exposed wall found by measuring distance around the outside of the conditioned area and enter in line 2.
4. Enter the dimensions of the house in line 3.
5. Enter the ceiling height and direction the glass faces in line 4.

(NOTE. Glass direction is used for reference mainly when the calculations are done room by room since you may have glass on all four directions.)
6. Calculate the gross exposed wall (distance around the house times wall height) and enter in block 5A in area or length column.

(NOTE. Measuring with a 100-foot tape makes measuring long stretches of walls easier and more accurate.)
7. Use lines B, C, & D if there are additional types of wall construction.

(NOTE. Since this is gross wall area do not subtract window and door openings.)
8. Calculate the area of windows and enter in block 6A under the area or length column.
9. Use additional lines if there are more types of window construction.
10. Glass doors also go in block 6 on a line by themselves if used.
11. Enter in block 7 the area of the windows and glass doors by the direction they face.
12. Calculate the area of the exterior doors and enter in block 8 under the area or length column.

ASSIGNMENT SHEET #1

13. Subtract window and door area from gross exposed wall area (5A) and enter net wall in 9A area or length column.

(NOTE. Be careful to subtract window areas only once since they are listed twice in blocks 6 and 7.)

14. Calculate the exposed ceiling area and enter in 10A under the area or length column.
15. Enter exposed floor in 11A, using square footage for wood floors and running feet of exposed edge for slab floors.
16. Enter the total area of windows plus exterior doors in block 12 area or length column.
17. Enter the number of people for the residence in left half of block 16 area or length column and number of sets of kitchen appliances in the right half.

(NOTE. It is customary to figure the number of bedrooms times two for the number of people, but using a busy room such as a family room where numbers of people congregates is another method. 1200 Btuh is the customary figure for a set of kitchen appliances, but if a washer and dryer are located in a conditioned space, as opposed to a utility room, add another 200 to 300 Btuh.)

18. From Table 2, manual J find the construction number that describes the windows, and enter in block 6 line a in the construction number column.

EXAMPLE. A double pane window, clear glass and metal frame would have a "const. no." of 3C.

19. In Table 2, are also found the heat transfer multiplier (HTM) for heating to be entered on the J sheet in the heating HTM column.

EXAMPLE: From table 2 we find that a 3C type window has an HTM of 50.8 at a 70° winter temperature difference.

20. From Table 2 find the construction numbers and winter HTM for the rest of the house, doors, net wall, ceilings and floor.

(NOTE: Block 6 will not have cooling HTMs and block 7 will be used for cooling HTM.)

21. Turn to Table 3 to find the cooling HTM for windows and glass doors, enter the proper HTM in the column next to the direction the glass faces.

22. Cooling HTM may be found from Table 4 for the doors, wall, ceiling and floor.

23. The heating and cooling HTM's for infiltration are entered in block 12 and found by completing the calculations in procedure "A" & "B" on the J-sheet.

(NOTE: See Table 5 for air changes per hour.)

ASSIGNMENT SHEET #1

24. Your J-sheet should have a construction number, a cooling and heating HTM on the same line that you have a number in the area or length column.
25. You are now ready to begin finding the heating and cooling BTUH.
26. Work blocks 6 through 12 by multiplying the area or length column times the heating and cooling HTM and entering under the BTUH column.

(NOTE: You may find it helpful to use 3 different color Hi-Lighter felt-tip markers to keep numbers in the proper column. You could make the area or length column yellow, heating HTM and heating BTUH column red, and the cooling HTM and cooling BTUH column blue.)

27. Find the heating subtotal by adding the heating BTUH column and enter in line 13.
 28. From Table 7A find the duct loss multiplier and enter under the HTM column.
 29. Calculate and enter results under the BTUH heating column, line 14.
 30. Add lines 13 and 14 and enter the total BTUH loss in line 15 in the heating BTUH column.
 31. Work the cooling BTUH column in the same manner entering the sensible BTUH gain in line 17.
 32. Using Table 7B enter and calculate the duct BTUH gain in line 18.
 33. Enter the total sensible gain in line 19.
 34. Complete procedure C to find latent infiltration gain.
 35. Complete procedure D to find equipment sizing loads.
 36. Fill in the heating and cooling summary on the front of the J-sheet.
 37. Equipment summary may be filled in when the units are selected.
- Have you instructor evaluate your calculations.

ASSIGNMENT SHEET #1

FIGURE 1

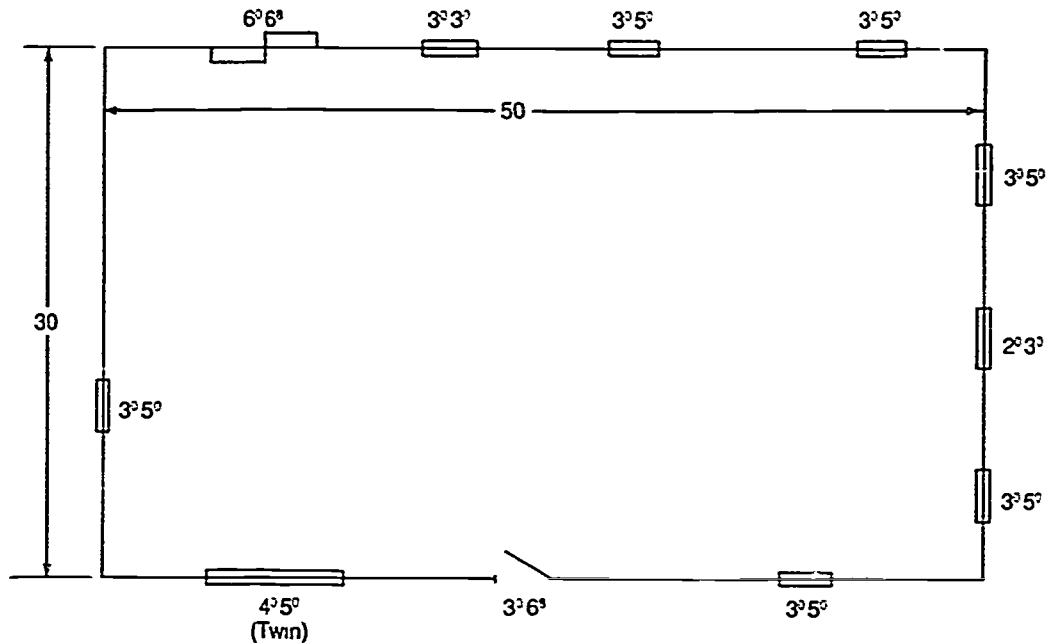
**Specifications:**

Windows — Clear, double pane, metal frame (half-drawn shades)

Glass Doors — Clear, double pane, metal frame

Doors — Solid wood with metal storm door

Walls — Wood frame, brick veneer, R-11 Batt, R-3.6 1" Bead board sheathing, 8' height

Roof — Dark color, vented attic, R-30 insulation over ceiling

Floor — Concrete slab, R-5 edge insulation

Ducts — Located in the attic R-4 insulation

Location — Tulsa, Oklahoma

Inside design temperature — 75° (requested) winter, summer 75°, 50 percent RH

Outside Design temperature — Winter 5°F (used by utility company) Summer 100°

Orientation — Front door faces East

Heating equipment — Gas-fired furnace

Type of construction — Average

**RESIDENTIAL LOAD CALCULATIONS
UNIT II****ASSIGNMENT SHEET #2 — DETERMINE SHADED AND UNSHADED GLASS
AREAS FOR USE IN HEAT GAIN CALCULATIONS**

Directions: Using Table 8 in *Manual J* calculate the shaded and unshaded areas of a window 3 feet wide by 5 feet high facing: 1. South, 2. East, and 3. West. The house has an overhang of 18 inches, the top of the window is 6 inches below the overhang and the property is located in Austin, Texas.

(NOTE. For your convenience, a Table 8 is included on the next page of this assignment sheet.)

1. Enter each window in the proper column, line A.
2. Enter overhang dimension in feet, line B.
3. Enter shade line multiplier, line C.
4. Enter distance between overhang and shade line in feet, line D.
5. Enter distance between overhang and top of window in feet, line E.
6. Enter shaded height of glass in feet, line F.
7. Enter height of window in feet, line G.
8. Enter unshaded height of glass in feet, line H.
9. Enter width of window in feet, line I.
10. Calculate and enter area of shaded glass, line J.
11. Calculate and enter area of unshaded glass, line K.

(NOTE. For heat gain calculations, areas of shaded glass may be considered as facing North, and areas of unshaded glass should be calculated according to the direction they face.)

- Have your instructor evaluate your calculations.

ASSIGNMENT SHEET #2

Courtesy Air Conditioning Contractors of America

Table 8
Shaded Glass Area

	Window Exposure	#1	#2	#3	#4
A. Direction Wall Faces	Exposure	_____	_____	_____	_____
B. Overhang Dimension	in Ft.	_____	_____	_____	_____
C. Shade Line Multiplier	See Table	_____	_____	_____	_____
D. Distance Between Overhang & Shade Line (Z in Ft.)	(BXC) =	_____	_____	_____	_____
E. Distance Between Overhang & Top of Window	Y in Ft.	_____	_____	_____	_____
F. Shaded Height of Glass (FL)	(D-E) =	_____	_____	_____	_____
G. Height of Window	W in Ft.	_____	_____	_____	_____
H. Unshaded Height of Glass (FL)	(G-F) =	_____	_____	_____	_____
I. Width of Window	(Feet)	_____	_____	_____	_____
J. Area, Shaded Glass (Sq. Ft.)	(FXI) =	_____	_____	_____	_____
K. Area, Unshaded Glass (Sq. Ft.)	(HXI) =	_____	_____	_____	_____

Direction Window Faces	Shade Line Multipliers					
	Degrees North Latitude					
	25	30	35	40	45	50
E or W	0.83	0.83	0.82	0.81	0.80	0.79
SE or SW	1.89	1.63	1.41	1.25	1.13	1.01
South	10.1	5.40	3.55	2.60	2.05	1.70

Use Table 8 to determine the square feet of shaded and unshaded glass areas beneath permanent external shading devices such as roof overhangs. A separate calculation is required for each window.

The total heat gain for a window that is partially shaded is equal to the sum of the heat gain through the shaded and unshaded areas. The heat gain through the shaded area is equal to the shaded area multiplied by the Table 3 heat transfer multiplier (HTM) for north (or external shading) glass. The heat gain through the unshaded area is equal to the unshaded area multiplied by the Table 3 heat transfer multiplier (HTM) for glass that has the same exposure as the window that is under consideration.

Shaded areas are not calculated for windows that face north, north-east or north-west because these exposures are not subjected to direct sunlight.

**RESIDENTIAL LOAD CALCULATIONS
UNIT II****ASSIGNMENT SHEET #3 — CALCULATE HEAT LOSS FOR
A RESIDENCE, ROOM BY ROOM**

Directions: Construction data, a floor plan and a basement plan for a residence accompany this assignment sheet. Refer to the construction data and to Figures 1 and 2 as required to calculate room by room heat loss for the sample residence. Use the room by room heat loss procedure outlined in *Manual J*, and complete entries on the J-sheet.

Procedure:

- 1 Complete winter design conditions on the front of the J-sheet from information found in *Manual J*, Table 1.
- 2 Complete the construction data on the front of the J-sheet from specifications of the residence to be calculated.
3. Enter the name of each area to be heated on line 1 of the J-sheet.
4. Enter the running ft. (linear) of exposed wall and enter on line 2.
5. Enter room dimensions on line 3.
6. Enter ceiling height and direction glass faces for each area on line 4.
- 7 Calculate gross exposed wall areas for each room and enter in block 5A in the area or length column (lines B, C, D may be used if there are other types of wall construction).
- 8 Calculate area of windows and enter in block 6A in the area or length column (use additional lines if more types of window construction).
- 9 Calculate areas of glass doors and enter in block 6B in the area or length column (use additional lines if more types of glass door construction).
10. Block 7 is not used for heating calculations.
- 11 Calculate the area of exterior doors for each room and enter in the area or length column in block 8.
- 12 Subtract window and door area from the gross exposed wall area and enter in block 9A.
13. Calculate the exposed ceiling area and enter in block 10A.

ASSIGNMENT SHEET #3

14. Enter exposed floor in block 11A.
(NOTE: For wood floors find the exposed area in square feet, for slab floors use the running foot of exposed slab edge.)
 15. Enter the construction number and heating HTM in the information column (located left of the entire house column) being sure they are on the same line where the area or length is entered (refer to Table 2 in manual J for construction numbers and HTM for heating).
 16. You should have a construction number and HTM for windows, glass doors, other doors, net wall, ceiling and floor.
 17. Enter the area of windows and doors in block 12 (use Table 5 in *Manual J* and procedure A on the back of the J-sheet to calculate the heating HTM that is to be entered on line 12 also).
 18. Multiply the heating HTM by the area and enter in the heating BTUH column (this is to be done for all the areas on the J-sheet).
 19. Find the subtotal by adding lines 6, 8, 9, 10, 11, 12 and entering on line 13.
 20. Calculate duct heat loss and enter on line 14 (refer to *Manual J* Table 7A).
 21. Add the duct loss to the subtotal and enter total heat loss on line 15.
 22. If ventilation air is not introduced through the equipment, the sum for the entire house column may be used to size the heating equipment.
 23. Transfer this heat loss information to the Heating Summary on the front of the J-sheet.
- Have your instructor evaluate your calculations.

ASSIGNMENT SHEET #3

Construction Data for a Residence

Windows — Clear, single pane, metal frame with storm windows (half-drawn shades)

Doors — Solid wood, metal frame storm door

Walls — Wood frame, brick veneer, R-11 Batt, R 3.6-1 inch beadboard sheathing, 8 foot wall height

Basement walls — 8 inch plus R-5 insulation

Roof — Dark color, vented attic

Ceiling — R-30

Floor — Concrete slab with R-5 perimeter insulation

Orientation — Front door faces west

Duct System — Attic location, R-4 insulation on duct

Location — Tulsa, Oklahoma

Design Conditions — (Utility)

Winter	+5°F	Outdoor temperature
	75°F	Indoor temperature
Summer	100°F	Outdoor temperature
	75°F	Indoor temperature
	50%	relative humidity

Heating Equipment — Gas-fired furnace

Type of Construction — Average

(NOTE: Because of the partition wall in the basement, there is a lesser temperature difference than for design conditions. The HTM for heating should be 13.1 and the HTM for cooling should be .9.)

ASSIGNMENT SHEET #3

FIGURE 1

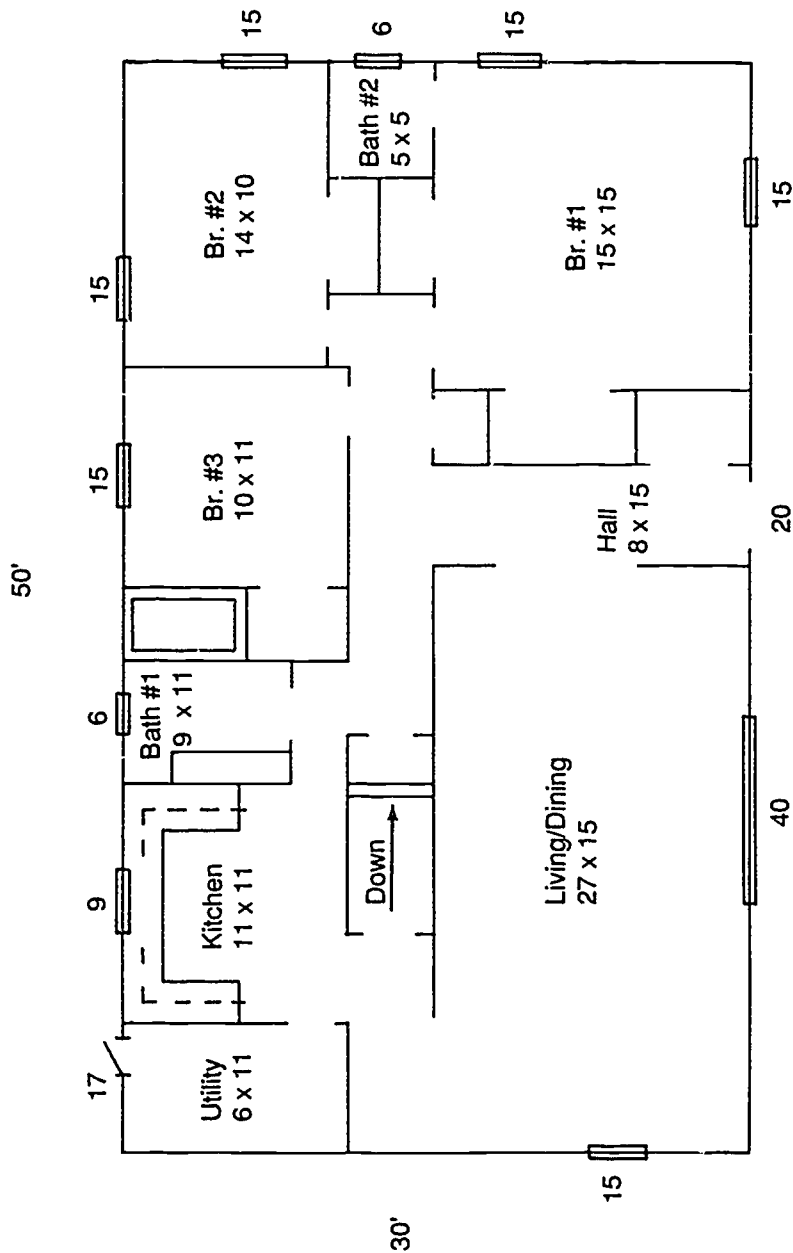

NOTE: See Figure 3 for blocking guidelines.

ASSIGNMENT SHEET #3

FIGURE 2

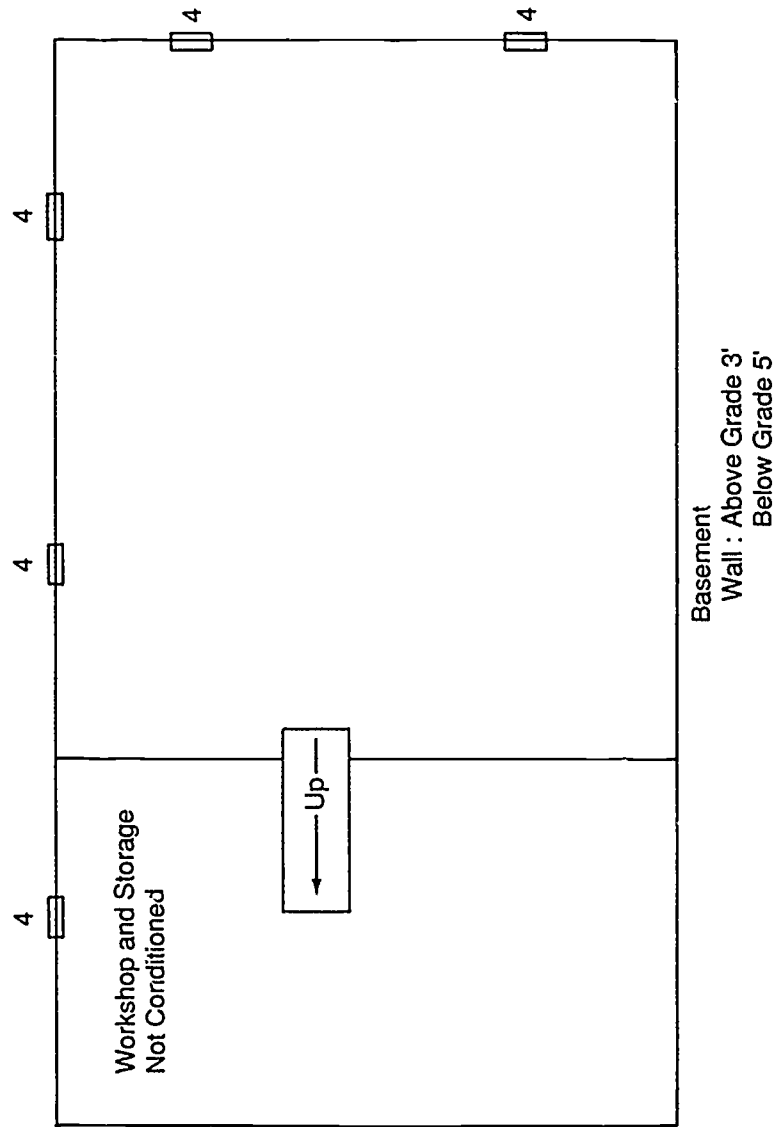

ASSIGNMENT SHEET #3

FIGURE 3

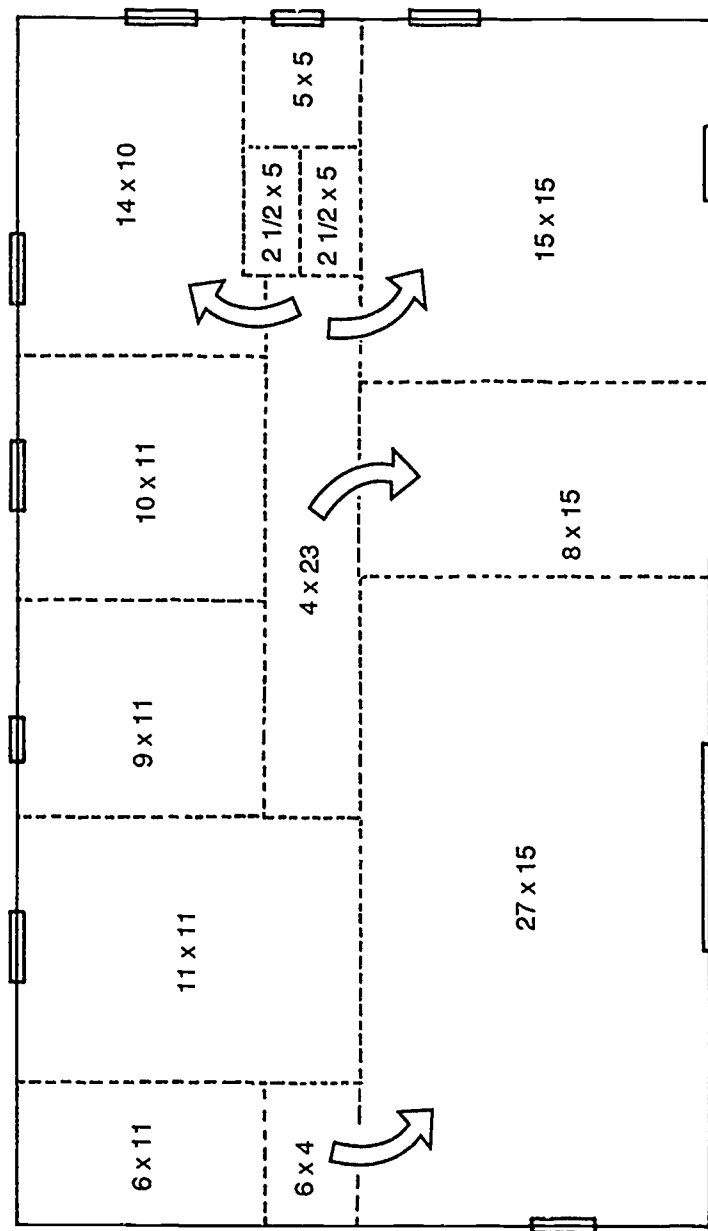

**RESIDENTIAL LOAD CALCULATIONS
UNIT II****ASSIGNMENT SHEET #4 — CALCULATE HEAT GAIN
FOR A RESIDENCE, ROOM BY ROOM**

Directions: Use the construction data and floor and basement plans from Assignment Sheet #3 to complete a room by room heat gain for a sample residence. Use the room by room heat gain procedure outlined in *Manual J* and complete entries on a J-sheet.

Procedure:

1. Complete the summer design conditions on the front of the J-sheet from information found in Table 1 (use 50% RH column for this assignment).
2. Enter the summer HTM for windows and glass doors found in Table 3A in block 7.

(NOTE: Notice that glass facing different directions does not have the same HTM as it did in heating calculation.)
3. Enter the summer HTM for doors (other than glass doors) found in Table 4 in block 8.
4. Enter the summer HTM for walls found in Table 4 in block 9A.
5. Enter the summer HTM for ceilings found in Table 4 in block 10A.
6. Enter the summer HTM for floors found in Table 4 in block 11A.
7. Use Table 5 and procedure B (on the back of the J-sheet) to determine the cooling HTM and enter in block 12.
8. Enter sensible internal loads due to appliances and people in line 16 (enter appliance in kitchen column, and people in living areas).
9. Multiply summer HTM times the area or length column and enter under the BTUH for cooling columns.
10. Add the cooling BTUH for each area and enter on line 17.
11. If the duct system is located in an unconditioned area, enter a duct gain allowance for each room on line 18 (duct gain multipliers are found in Table 7-B).
12. Add line 17 to line 18 for each room and the entire house column and enter on line 19 (if ventilation is used, the sensible loads must be calculated).
13. Use procedure C (on the back of form J-1) to calculate the infiltration load for the entire house.
14. Complete procedure D (on back of form J-1) to estimate total sensible and total latent loads to be satisfied by the cooling equipment (RSM may be found in Table 6).

ASSIGNMENT SHEET #4

15. Enter heat gain information in the cooling summary on the front of the J-sheet.
 16. The equipment summary may be filled after the equipment is chosen that meets the recommendations made in *Manual J* or by local codes.
- Have your instructor evaluate your calculations.

RESIDENTIAL LOAD CALCULATIONS
UNIT II

ANSWERS TO ASSIGNMENT SHEETS

Worksheet forms are courtesy of Air Conditioning Contractors of America

Assignment Sheet #1

WORKSHEET FOR MANUAL J
LOAD CALCULATIONS FOR RESIDENTIAL AIR CONDITIONING

For Name			
Address			
City and State or Province			
By Contractor			
Address			
City			

Design Conditions			
Winter		Summer	
Outside db	+5 F	Inside db	75 F
Winter Design Temperature Difference	70 F	Outside db	100 F
		Inside db	75 F
		Summer Design Temperature Difference	25 F
		Room RH	50%
		Daily Range	MED (30GR)

Heating Summary			
Total Heat Loss for Entire House (Line 15) =	46,267	Btuh	
Ventilation CFM =	—	Winter Design Temperature Difference =	70 F
Heat Required for Ventilation Air = 1.1 X	—	CFM X	—
Design Heating Load Requirement =	46,267	(house)	—
		F =	—
		(Vent) =	46,267
		Btuh	

Cooling Summary			
Total Sensible Gain	23,480	Btuh (Calculation Procedure D)	Design Temperature Swings
Total Latent Gain +	3,420	Btuh (Calculation Procedure D)	Normal 3 (✓) 4.5 ()
Total = Sens + Lat =	26,900	Btuh	Ventilation CFM =
			-0-

Equipment Summary			
Make	Model	Type	
Heating Input (Btuh)		Heating Output (Btuh)	Efficiency
Sensible Cooling (Btuh)		Latent Cooling (Btuh)	Total (Btuh)
COP EER SEER HSPF		Cooling CFM	Heating CFM
Space Thermostat	Heat ()	Cool ()	Heat Cool ()
			Night Setback ()

Construction Data	
Windows CLEAR, DOUBLE PANE, METAL FRAME	Floor CONCRETE SLAB, R-5 SLAB INSULATION AROUND PERIMETER
Doors SOLID WOOD WITH METAL STORM DOOR	Partitions
Walls WOOD FRAME, BRICK VENEER, R-11 BATT, R-36 1" BEAD BOARD SHEATHING, (8' HEIGHT)	Basement Walls
Roof DARK COLOR, VENTED ATTIC	Ground Slab
Ceiling R-30	* DUCT SYSTEM LOCATED IN ATTIC R-4 INSUL. ON DUCT - GAS FURNACE AVERAGE CONST.

File

ANSWERS TO ASSIGNMENT SHEETS

Assignment Sheet #1 (continued)

Procedure A - Winter Infiltration HTM Calculation

1	Winter Infiltration CFM				
	1	AC/HR x 12000	Cu FT x 0.0167 =	200	CFM
			Volume		
2	Winter Infiltration Btuh				
	11 x 200	CFM x 70	Winter TO =	$15,400$	Btuh
3	Winter Infiltration HTM				
	$15,400$	Btuh - 205	Total Window =	75.12	HTM
			& Door Area		

Procedure B - Summer Infiltration HTM Calculation

1	Summer Infiltration CFM				
	$.5$	AC/HR x 12000	Cu FT x 0.0167 =	100	CFM
			Volume		
2	Summer Infiltration Btuh				
	11 x 100	CFM x 25	Summer TO =	2750	Btuh
3	Summer Infiltration HTM				
	2750	Btuh - 205	Total Window =	13.41	HTM
			& Door Area		

Procedure C - Latent Infiltration Gain

	0.68 x 30	gr diff x 100	Summer CFM =	$2,040$	Btuh
--	---------------	-----------------	--------------	---------	------

Procedure D - Equipment Sizing Loads

1	Sensible Sizing Load				
	Sensible Ventilation Load				
	11 x	Vent CFM x	Summer TO =	$—$	Btuh
	Sensible Load for Structure (Line 19)		+	$22,362$	Btuh
	Sum of Ventilation and Structure Loads		=	$22,362$	Btuh
	Rating & Temperature Swing Multiplier*		x	1.05	RSM
	Equipment Sizing Load - Sensible		=	$23,480$	Btuh
2	Latent Sizing Load				
	Latent Ventilation Load				
	0.68 x	Vent CFM x	gr diff =	$—$	Btuh
	Internal Loads = 230 x 6	No People	+	1380	Btuh
	Infiltration Load from Procedure C		+	2040	Btuh
	Equipment Sizing Load - Latent		=	3420	Btuh

* Refer to Table 6

ANSWERS TO ASSIGNMENT SHEETS

Assignment Sheet #1 (continued)

1 Name of Room		Furnace Room													
2 Running Ft Exposed Wall		160													
3 Room Dimensions Ft		50x30													
4 Ceiling Ht Ft		8 N-S-E-W													
TYPE OF EXPOSURE	Const No	HIM		Area or Length	Brub		Area or Length	Brub		Area or Length	Brub		Area or Length	Brub	
		Htg	Cig		Htg	Cig		Htg	Cig		Htg	Cig			
5 Gross	a			1280											
Exposed	b														
Walls and	c														
Partitions	d														
6 Windows and Glass Doors Heating	a	30	50.8	145	7366										
	b														
	c														
	d	80	50.8	40	2032										
7 Windows and Glass Doors Heating	North			22	36	792									
	E & W or NE & NW			61	134	8174									
	South or SE & SW			33	15	495									
	Other														
8 Other Doors	a	10F	22.4	9.2	20	448	184								
	b														
	c														
	d														
9 Net Exposed Walls and Partitions	a	12F	49	2.0	1075	5268	2150								
	b														
10 Ceilings	a	16G	2.3	1.6	1500	3450	2400								
	b														
11 Floors	a	22B	28.7	-0-	160	4592	-0-								
	b														
12 Exposed HIM		75	12	13.4	205	15400	2750								
13 Sub Tot Brub Loss						38556									
14 Duct Brub Loss		20				7,711									
15 Total Brub Loss						46,267									
16 People and Appliances					6/1	3,000									
17 Sensible Brub Gain						19,445									
18 Duct Brub Gain			15			2,917									
19 Total Sensible Gain						22,362									

ANSWERS TO ASSIGNMENT SHEETS

Assignment Sheet #2

		#1	#2	#3
1.	A.	So	E	W
2.	B.	1.5	1.5	1.5
3.	C.	5.40	.83	.83
4.	D.	8.1	1.2	1.2
5.	E.	.5	.5	.5
6.	F.	7.6	.7	.7
7.	G.	5	5	5
8.	H.	-2.6	4.3	4.3
9.	I.	3	3	3
10.	J.	22.8	2.1	2.1
11.	K.	-7.8	12.9	12.9

(NOTE: Negative figures indicate that glass is totally shaded.)

ANSWERS TO ASSIGNMENT SHEETS

Assignment Sheets #3 and #4

WORKSHEET FOR MANUAL J

LOAD CALCULATIONS FOR RESIDENTIAL AIR CONDITIONING

For Name _____		Address _____		City and State or Province _____	
By Contractor _____		Address _____		City _____	
Design Conditions					
Winter			Summer		
Outside db	5 (13) °F	Inside db	75 °F	Outside db	100 (98) °F
Winter Design Temperature Difference	70 °F	Summer Design Temperature Difference	25 °F	Room RH	50%
				Daily Range	MED. (30-60°)
Heating Summary					
Total Heat Loss for Entire House (Line 15) =	39637				Btuh
Ventilation CFM =	—	Winter Design Temperature Difference =	70		°F
Heat Required for Ventilation Air = 1.1 X	—	CFM X	—		Btuh
Design Heating Load Requirement =	39637	(house)	—	(Vent) =	39637 Btuh
Cooling Summary					
Total Sensible Gain	21,276	Btuh (Calculation Procedure D)	Design Temperature Swings		
Total Latent Gain +	3420	Btuh (Calculation Procedure D)	Normal 3° (✓) 14.5° ()		
Total = Sens + Lat =	24,696	Btuh	Ventilation CFM =	-0-	
Equipment Summary					
Make	Model	Type			
Heating Input (Btuh)		Heating Output (Btuh)		Efficiency	
Sensible Cooling (Btuh)		Latent Cooling (Btuh)		Total (Btuh)	
COP/EER/SEER/HSPF		Cooling CFM		Heating CFM	
Space Thermostat	Heat ()	Cool ()	Heat/Cool ()	Night Setback ()	
Construction Data					
Windows	CLEAR SINGLE PANE METAL FRAME w/STORM WINDOWS, HALF-DRAWN SHADES. (NONE IN BASEMENT)	Floor	CARPETED WOOD FLOOR WITH R-11 INSULATION IN UNHEATED AREA	Partitions	R-11 WITH 1/2" GYPSUM BOARD (R-0.5)
Doors	SOLID WOOD, WITH METAL STORM DOOR	Basement Walls	8" MASONRY + R-5 3' ABOVE GRADE, 5' BELOW GRADE		
Walls	WOOD FRAME WITH BRICK VENEER, R-11 CAVITY INSULATION, 1" R-3.6 BEAD BOARD SHEATHING	Ground Slab	* FRONT DOOR FACES WEST		
Roof	VENTED ATTIC, DARK ROOF		* DUCTS LOCATED IN CONDITIONED SPACE		
Ceiling	R-30		* AVERAGE CONSTRUCTION		

File



ANSWERS TO ASSIGNMENT SHEETS

Assignment Sheets #3 and #4 (Continued)

Procedure A - Winter Infiltration HTM Calculation

1. Winter Infiltration CFM	<u>0.7</u> AC/HR x <u>14,970</u> Cu. FT x 0.0167 = <u>175</u> CFM
	Volume
2. Winter Infiltration Btuh	1.1 x <u>175</u> CFM x <u>70</u> Winter TD = <u>13,475</u> Btuh
3. Winter Infiltration HTM	<u>13,475</u> Btuh - <u>204</u> Total Window = <u>66</u> HTM
	& Door Area

Procedure B - Summer Infiltration HTM Calculation

1. Summer Infiltration CFM	<u>0.4</u> AC/HR x <u>14,970</u> Cu. FT x 0.0167 = <u>100</u> CFM
	Volume
2. Summer Infiltration Btuh	1.1 x <u>100</u> CFM x <u>25</u> Summer TD = <u>2,750</u> Btuh
3. Summer Infiltration HTM	<u>2,750</u> Btuh - <u>204</u> Total Window = <u>13.5</u> HTM
	& Door Area

Procedure C - Latent Infiltration Gain

0.68 x <u>30</u> gr. diff. x <u>100</u>	Summer CFM = <u>2,040</u> Btuh
---	--------------------------------

Procedure D - Equipment Sizing Loads

1. Sensible Sizing Load	
Sensible Ventilation Load	
1.1 x Vent. CFM x Summer TD =	<u>—</u> Btuh
Sensible Load for Structure (Line 19)	+ <u>20,263</u> Btuh
Sum of Ventilation and Structure Loads	= <u>20,263</u> Btuh
Rating & Temperature Swing Multiplier *	x <u>1.05</u> RSM
Equipment Sizing Load - Sensible	= <u>21,276</u> Btuh
2. Latent Sizing Load	
Latent Ventilation Load	
0.68 x Vent CFM x gr diff =	<u>—</u> Btuh
Internal Loads = 230 x <u>6</u> No People	+ <u>1380</u> Btuh
Infiltration Load From Procedure C	+ <u>2040</u> Btuh
Equipment Sizing Load - Latent	= <u>3420</u> Btuh

* Refer to Table 6

ANSWERS TO ASSIGNMENT SHEETS

Assignment Sheets #3 and #4 (Continued)

NOTE: USE CALCULATION PROCEDURE D TO CALCULATE THE EQUIPMENT DESIGN LOADS

DO NOT WRITE IN SHAD BLOCKS

1 Name of Room				2 Heating Ft Exposed Wall		3 Cooling Ft Exposed Wall		4 Ceiling Height		5 Direction of Wind Faces		6 TYPE OF EXPOSURE		7		8		9		10		11		12		13		14							
LIVING/DINING				UTILITY		KITCHEN		BATH #1		BR #3		BR #2		BATH #2		BR #1		ENTRY HALL		REG. ROOM															
46 CORNER 27X15+OPENING				17		11		9		10		24		5		30		8 CENTRAL		126															
B' NEW				6X11		11X11 + STAIRS		9X11		10X11		4X10+CLO		5X5		15X15+CLO		8X15+HALL 4X23		30X33															
TYPE OF EXPOSURE	Area	Height	HM	Area	Height	HM	Area	Height	HM	Area	Height	HM	Area	Height	HM	Area	Height	HM	Area	Height	HM	Area	Height	HM	Area	Height	HM	Area	Height	HM					
Walls - Exposed	148	10.1	3.1	272	2747	843																													
Walls - Insulated	158	5.2	-0-	480	2496	-0-																													
Partitions	130	3.1	0.9	240	744	216																													
Windows	20	4.5	1.6	7598	55	2503																													
Windows and Glass	22	15		330	15	330																													
Doors	61	100		6100	40	2440																													
Other	33	36		1182																															
Basement	74/40	8/D		592																															
Other Doors	10F	22.4	9.2	37	829	340																													
Net	12F	4.9	2.0	1092	5351	2184	313	1534	626	119	503	238	79	307	158	66	323	132	65	319	13062	794	324	34	167	68	210	1029	420	44	216	88			
Exposed	148	10.1	3.1	272	2747	843																													
Insulated	158	5.2	-0-	480	2496	-0-																													
Partitions	130	3.1	0.9	240	744	216																													
Windows	164	2.3	1.6	1500	3450	2400	429	907	686	66	152	106	165	380	264	99	228	158	110	253	17452	350	243	25	58	40	237	545	379	212	488	339			
Other	196	2.5	-0-	510	1275	-0-	279	698	-0-	66	165	-0-	165	413	-0-	-0-	-0-	-0-	-0-	-0-	-0-	-0-	-0-	-0-	-0-	-0-	-0-	-0-	-0-	-0-	-0-				
Basement	21A	1.7	-0-	990	1683	-0-																													
Infiltration	HM	16	13.5	204	13464	2750	55	3630	743	17	112	230	9	594	122	6	396	81	15	990	2030	1980	405	6	396	81	30	1980	405	20	1320	270	16	1056	216
Soil Heat Loss																																			
Duct Heat Loss																																			
Total Heat Loss																																			
People	6/1																																		
Sensible Heat Gain																																			
Duct Heat Gain																																			
Total Sensible Gain																																			

**RESIDENTIAL LOAD CALCULATIONS
UNIT II**

TEST

Name _____ Score _____

1. Match the terms on the right with their correct definitions.

- | | | |
|---------|---|-----------------------------|
| _____a. | The amount of heat required to raise the temperature of one pound of water one degree Fahrenheit | 1. Ventilation |
| _____b. | The unit used to express hourly heat flow | 2. Gross exposed walls |
| _____c. | The movement of heat from one substance or region to another | 3. Ton of refrigeration |
| _____d. | An index of heat transfer through one square foot of a structural component at specific design conditions | 4. Btu |
| _____e. | The rating given to a material's ability to resist heat transfer | 5. Infiltration |
| _____f. | A heat transmission coefficient arrived at by adding the total resistance of a component to the effects of convection on inside and outside surfaces of the component and then dividing one by the figure to get the reciprocal | 6. ITM |
| _____g. | The total square footage, including doors and windows, of walls exposed to the outside | 7. Internal heat gain |
| _____h. | The total square footage, excluding doors and windows, of walls exposed to the outside | 8. Cfm |
| _____i. | A wall separating a conditioned space from an unconditioned space | 9. Btuh |
| _____j. | Walls of upper rooms exposed to attic temperatures | 10. Heat transfer |
| _____k. | Sensible heat gain produced by people and appliances | 11. U-value |
| _____l. | Heating and cooling lost or gained because of air leakage and heat transfer in ducts | 12. Net exposed walls |
| | | 13. Duct loss and duct gain |
| | | 14. Knee walls |
| | | 15. R-value |
| | | 16. Exposed partition |
| | | 17. Latent load |

TEST

- ___m. Controlled air brought into a structure
- ___n. Uncontrolled air that leaks into a structure
- ___o. The load associated with the amount of moisture a structure gains or loses from infiltration, ventilation, or from people and machines
- ___p. Cubic feet per minute
- ___q. A refrigerating effect equal to 12,000 Btuh
2. Select true statements concerning the value of standardized load calculations. Place an "X" beside each true statement.
- ___a. Charts and tables in most load estimating forms reflect years of cumulative technical information through which the air conditioning industry has improved and simplified the load calculation process.
- ___b. Residential heating and cooling load estimates can be calculated only by engineers or scientists because the forms are filled with sophisticated mathematical formulas.
3. Complete statements concerning factors in determining heat loss and heat gain. Circle the material that best completes each statement.
- a. Size of structure, the (transmission) (insulating) quality of its components, and orientation
- b. Outside design temperature for (heat loss only) (heat loss and heat gain)
- c. Daily temperature (range) (difference) for heat gain
- d. Inside (air) (design) temperature
- e. Design (temperature difference) (conditions) for heat loss and heat gain
- f. HTM for (heating or HTM cooling) (cooling only)
4. Select true statements concerning the steps in calculating heat transfer multipliers. Place an "X" beside each true statement.
- ___a. Determine the R-value of the construction component.
- ___b. Determine the U-value of the construction component.
- ___c. Determine the HTM for heating by multiplying the U-value by the design temperature difference.

TEST

- ____d. Determine the HTM for cooling the same way as the HTM for heating.
5. Select true statements concerning factors to consider when sizing heating equipment. Place an "X" beside each true statement.
- ____a. Type of structure
- ____b. Heat loss determined from design conditions
- ____c. Temperature rise
- ____d. Static pressure
- ____e. Output capacity should never be less than the estimated heating load or less than specified by local codes.
- ____f. Output capacity should never be more than 15 percent above the estimated heating load or more than specified by local codes.
- ____g. Since the heating system design is most important, it should be completed before sizing cooling equipment.
6. Select true statements concerning factors to consider when sizing cooling equipment. Place an "X" beside each true statement.
- ____a. Type of structure
- ____b. System design should be compatible with heating load and projected heating equipment.
- ____c. Heat gain determined from design conditions
- ____d. Cfm correctly related to humidity control
- ____e. Output capacity should never be less than ten percent below the estimated cooling load or less than specified by local codes.
- ____f. Output capacity should never be more than 20 percent above the estimated cooling load or more than specified by local codes.
7. Complete statements concerning ways structural modifications affect equipment selection. Circle the material that best completes each statement.
- a. When equipment will facilitate the cooling load, but not the heating load:
- 1) (Decrease) (Increase) the amount of insulation in walls and over ceilings.
 - 2) Install double pane (storm windows) (entry doors)
 - 3) (Tighten) (Weatherstrip) doors and windows

TEST

- b. When equipment will facilitate the heating load, but not the cooling load:
 - 1) Shade windows with (large roof overhangs) (drapes, shades, solar screens, roof overhangs, and awnings).
 - 2) Select (dark) (light) outside colors, especially for (walls) (roofs).
 - 3) (Decrease) (increase) the amount of insulation in walls and over ceilings.
- c. Structural modifications can: improve the (selection) (compatibility) of heating and cooling equipment.
- d. Structural modifications can: (manage) (conserve) vital energy.

(NOTE: If the following activities have not been accomplished prior to the test, ask your instructor when they should be completed.)

- 8. Calculate heat loss and heat gain for a residence using "entire house" for a quick calculation. (Assignment Sheet #1)
- 9. Determine shaded and unshaded glass areas for use in heat gain calculations. (Assignment Sheet #2)
- 10. Calculate heat loss for a residence, room by room. (Assignment Sheet #3)
- 11. Calculate heat gain for a residence, room by room. (Assignment Sheet #4)

RESIDENTIAL LOAD CALCULATIONS UNIT II

ANSWERS TO TEST

1. a. 4 f. 11 k. 7 p. 8
 b. 9 g. 2 l. 13 q. 3
 c. 10 h. 12 m. 1
 d. 6 i. 16 n. 5
 e. 15 j. 14 o. 17

2. a

3. a. Insulating
 b. Heat loss and heat gain
 c. Range
 d. Design
 e. Temperature difference
 f. Heating or HTM cooling

4. a, b, c

5. a, b, c, d, e

6. a, b, c, d

7. a. 1) Increase
 2) Storm windows
 3) Weatherstrip
 b. 1) Drapes, shades, solar screens, roof overhangs or awnings
 2) Light roofs
 3) Increase
 c. Compatibility
 d. Conserve

8. Evaluated to the satisfaction of the instructor

9. Evaluated to the satisfaction of the instructor

10. Evaluated to the satisfaction of the instructor

11. Evaluated to the satisfaction of the instructor



RESIDENTIAL DUCT DESIGN AND SIZING UNIT III

UNIT OBJECTIVE

After completion of this unit, the student should be able to design and size a duct system and design an air distribution system from a drawing. These competencies will be demonstrated by completing the assignment and job sheets, and by scoring a minimum score of 85 percent on the written test.

SPECIFIC OBJECTIVES

After completion of this unit, the student should be able to:

1. Match terms related to residential duct design and sizing with their correct definitions.
2. Identify types of supply duct systems.
3. Solve problems concerning factors affecting system design with the effects they have on the system.
4. Match major steps in air system design with their procedures.
5. Select factors affecting return air duct design.
6. List four locations of registers and grilles.
7. Solve problems concerning advantages and disadvantages for locations of registers and grilles.
8. Complete statements concerning climatic zone conditions.
9. Match air control devices with their applications.
10. Complete statements concerning factors to consider in the distribution of conditioned air.
11. Match grille design factors with their meanings.
12. Match outlet placement with recommended velocities.
13. Select true statements concerning air duct calculators.

SPECIFIC OBJECTIVES

14. Solve problems using the friction loss per 100 feet chart. (Assignment Sheet #1)
15. Solve problems using the friction chart for flex duct. (Assignment Sheet #2)
16. Design an air distribution system from a drawing. (Assignment Sheet #3)
17. Demonstrate the ability to:
 - a. Determine the pressure drop across an evaporator coil. (Job Sheet #1)
 - b. Determine the CFM being delivered by a selected forced air system. (Job Sheet #2)

**RESIDENTIAL DUCT DESIGN AND SIZING
UNIT III**

SUGGESTED ACTIVITIES

- A. Obtain additional materials and/or invite resource people to class to supplement/reinforce information provided in this unit of instruction.

(NOTE: This activity should be completed prior to the teaching of this unit.)

- B. Make transparencies from the transparency masters included with this unit.
- C. Provide students with objective sheet.
- D. Discuss unit and specific objectives.
- E. Provide students with information and assignment sheets.
- F. Discuss information and assignment sheets.

(NOTE: Use the transparencies as needed to enhance the information.)

- G. Provide students with job sheets.
- H. Discuss and demonstrate the procedures outlined in the job sheets.
- I. Review and demonstrate the use of measuring instruments, especially an inclined manometer and a velometer or anemometer.
- J. Integrate the following activities throughout the teaching of this unit:
1. Arrange a field trip to a residence under construction so the students can see the duct system being installed.
 2. Secure duct calculators for student use.
 3. Secure grille manufacturer's engineering catalog for use in grille selection.
 4. Meet individually with students to evaluate their progress through this unit of instruction, and indicate to them possible areas for improvement.

- K. Give test.
- L. Evaluate test.
- M. Reteach if necessary.

REFERENCES USED IN DEVELOPING THIS UNIT

- A. Rutkowski, Hank. *Manual D, Duct Design for Residential Winter and Summer Air Conditioning and Equipment Selection*. Washington, DC 20036: Air Conditioning Contractors of America.

SUGGESTED ACTIVITIES

- B. *Manual E., Room Air Distribution Considerations.* Washington, DC 20036: Air Conditioning Contractors of America, 1965.
- C. *Manual G, Selection of Distribution System.* Washington, DC: 20036: Air Conditioning Contractors of America, 1965.
- D. *Manual L., Installation Practices for Warm Air Heating and Cooling Systems.* Washington, DC 20036: Air Conditioning Contractors of America, 1969.
- E. *Understanding the Friction Chart.* Washington, DC 20036: Air Conditioning Contractors of America, 1967.

SUGGESTED SUPPLEMENTAL MATERIAL

- A. *Manual A, What is Comfort Air Conditioning?* Washington, DC 20036: Air Conditioning Contractors of America, 1961.
- B. *Manual B, Principles of Air Conditioning.* Washington, DC 20036: Air Conditioning Contractors of America, 1970.
- C. *Manual C, What Makes a Good Air Conditioning System.* Washington, DC 20036: Air Conditioning Contractors of America, 1966.
- D. "The Total Comfort Story" (Customer Education Pamphlet). Washington, DC 20036: Air Conditioning Contractors of America, n.d.
- E. Just as with RIGHT-J for load calculations, ACCA offers the RIGHT-D computer software for residential duct sizing. The program is versatile and effective for branches, trunks, and systems of various design. RIGHT-D is available for both 5¼" and 3½" floppy drives for IBM or IBM compatible computers. Write ACCA at 1513 16th Street NW, Washington, DC 20036, or telephone 202-483-9370.
- F. Hand-held air duct calculators may be available from a local AC dealer or distributor. If not they can be ordered for students. Two sources for inexpensive hand-held calculators are:

The Lima Register Company
 P.O. Box 28
 Lima, Ohio 45802
 For information call (419)228-1411

Lennox International, Inc.
 P.O. Box 799900
 Dallas, TX 75379-9900
 For information call (214)497-5281

**RESIDENTIAL DUCT DESIGN AND SIZING
UNIT III**

INFORMATION SHEET

I. Terms and definitions

- A. **Proprietary systems** — Commercially designed "Total" air conditioning systems including mechanical equipment, ducts, fittings, registers and grilles
- B. **Static pressure** — The force per unit area, perpendicular to the direction of flow in a duct

(NOTE: the pressure within the duct work is positive if a supply duct, and negative if a return duct)
- C. **Plenum** — A box-like fitting that the air handler either discharges air into (supply) or receives air from (return)
- D. **Duct** — Tube or channel used to convey air
- E. **Boot** — A duct fitting that adapts the duct to a wall stack, a register or grille
- F. **Take-off** — The point of departure from a duct to which a duct fitting is attached to accomplish branching of ductwork
- G. **Equivalent length** — A method of expressing the friction loss of duct fittings by comparing the fitting loss to the loss in a straight duct
- H. **Actual length** — The length of a duct expressed in feet and inches
- I. **Effective length** — Expressed in feet is the sum of actual and equivalent length (the design parameter for calculating the friction loss for a duct run)
- J. **Branch** — A section of duct that services one outlet, sometimes called a runout
- K. **Trunk** — A section of duct that handles more than one outlet
- L. **Diffuser** — A supply air outlet composed of deflecting elements discharging air in various directions and patterns to accomplish mixing of supply and room air
- M. **Equal friction method** — Sizes the duct system so that the friction loss for the supply duct runs are approximately equal and the friction loss for all the return runs are approximately the same

(NOTE: This commonly used basis for duct design means areas requiring more air, or distance areas requiring the same air volume, require larger ducts to overcome or "equalize" the increased friction.)

- N. **System pressure** — The sum of the negative and positive static pressures being exerted by a blower

INFORMATION SHEET

- O. **Convection currents** — Air currents set in motion by cooling and warming of air brought in contact with hot or cold surfaces such as walls or windows
- P. **Stratification of air** — Condition in which there is little (15 fpm) or no air movement in a room; air lies in temperature layers

(NOTE: In the summer this is identified as the region near the ceiling where a layer of smoke will hang for some time; in the winter it is identified as a cold layer of air near the floor.)
- Q. **Temperature gradient** — Temperature change from one level or stratum to the next as in the change from floor to ceiling
- R. **Cascade (waterfall) effect** — The transfer of large masses of air due to convection currents in a structure often caused by warm air rising and cooler air falling through building accesses such as stairs
- S. **Wall stack** — A thin, rectangular duct which runs vertically inside a wall
- T. **Ceiling or wall effect** — A peculiar ability of moving air to cling to a ceiling or a wall
- U. **Fpm** — Feet per minute, a measurement of velocity
- V. **Floor warming** — Floor heating by burying ducts in concrete slab floors or by running supply ducts under floors
- W. **Pressure drop** — The phenomenon of static pressure diminishing from maximum at the blower to zero after passing through an outlet regardless of duct length
- X. **IWG** — Inches of water gauge
- Y. **Heating air flow factor (HF)** — Amount of air flow rate required to deliver 1.0 BTUH of heat to any outlet in the structure
- Z. **Cooling air flow factor (CF)** — Amount of airflow rate required to deliver 1.0 BTUH of sensible cooling to any outlet in the structure
- AA. **Sensible heat ratio (SHR)** — Ratio of calculated sensible load to the calculated total load

(NOTE: This is a step in arriving at the estimated design CFM.)

II. Types of supply duct systems (Transparency 1)

- A. Radial or spider
- B. Trunk and branch
 - 1. Reducing plenum

INFORMATION SHEET

2. Extended plenum

C. Perimeter loop

(NOTE: *Manual D* no longer covers this type system)

1. Trunk duct

2. Radial duct

III. Factors affecting system design and the effects that they have on the system

A. Duct length

1. Volume — Greater duct length reduces volume of air to be delivered
2. Pressure — Greater duct length increases static pressure and resistance to air flow
3. Duct gain or loss — Greater duct length increases temperature of cold air (gain), or reduces temperature of warm air passing through the duct (loss)

B. Equivalent length — Changes in shape or direction of ducts will reduce volume of air flow because of increased resistance caused by air flow friction (Transparency 2)

C. Effective length (Transparency #2)

1. Prime factor used to determine duct diameter for a given pressure in the system
2. Determined by adding the actual duct work length plus the equivalent length of fittings

D. System pressure

1. Prime factor used to determine duct diameter for a given air volume in a system
2. Selection is made after determining capability of equipment blower
3. Apportioned between supply ducts and return ducts

E. Design air volume

1. Transmits the total heat available from the heat source proportional to the amount of air delivered
2. Moves the proper CFM of air over the evaporator during cooling

INFORMATION SHEET

- F. Pressure drop per 100 feet — Affects the selection of the duct diameter; if the factor is too small, the duct diameter will be too large
- G. Temperature rise
 - 1. A decrease in air volume will result in an increase in temperature rise
 - 2. An increase in air volume will result in a decrease in temperature rise
- H. Duct wrap (insulation) — Reduces heat loss or heat gain in duct and eliminates condensation if there is a vapor barrier
- I. Supply outlets — Size, design, and location affect the efficiency of the system and degree of comfort

IV. Major steps in air system design and their procedures

- A. Select air distribution region.
 - 1. Determine climatic region.
 - 2. Determine design of structure.
 - 3. Determine location of ducts.
 - 4. Determine best type of distribution system.
- B. Select heating and cooling equipment.
 - 1. Calculate total system load.
 - 2. Determine type of equipment to be used.
 - 3. Calculate heating and cooling CFM.
 - 4. Select proper sized unit for heating.
 - 5. Select proper sized unit for cooling.
 - 6. Determine location of condensing unit, heating equipment, and thermostat.
- C. Lay out and size duct work (Transparencies 3, 4, 5, 6, 7, 8, 9, 10, 11, 12 and 13).
 - 1. Determine appropriate location of duct work.
 - 2. Calculate number of outlet and inlet openings.
 - 3. Calculate the CFM required for each outlet.
 - 4. Determine the type of duct to be used and draw the runs.

INFORMATION SHEET

5. Obtain the equivalent length of fittings.
 6. Determine the total effective length of ducts.
 7. Determine branch duct design static.
 8. Size duct using appropriate charts.
 9. Size trunk ducts.
- D. Select registers and grilles for supply and return air.
1. Examine floor plan to determine appropriate outlet register.
 2. Select appropriate registers based on correct distribution patterns.
 3. Select the proper return air grille size.
- V. **Factors affecting return air duct design**
- A. Return air inlets are not normally placed in a kitchen or bathroom.
 - B. An optimum system has a return air inlet in each bedroom.
 - C. Return air inlets are normally placed so that air from one room is not moved through another before entering the return inlet.
 - D. Return air duct systems must be designed for a design air volume equal to or greater than the supply air volume.
 - E. Return air inlets should be placed on every level of a split level residence.

(NOTE: In two story residences and split level houses with only one system, the upstairs return air system should be oversized by at least 10%; in small ranch houses, 1600 sq. ft. or less, a simple one return trunk duct is sometimes adequate, depending on room layout.)
 - F. Combined return air pressure and supply pressure must not exceed total available static pressure of the blower.
 - G. Return air inlets are usually placed near inside walls which allows shorter duct work.
 - H. Doors over add-on carpet need to be trimmed at the bottom so air can flow to the return.
- VI. **Locations of registers and grilles**
- A. Perimeter (radial, loop, or trunk and branch)
 - B. High inside wall

INFORMATION SHEET

C. Low inside wall

D. Ceiling

VII. Advantages and disadvantages for locations of registers and grilles**A. Advantages of perimeter systems**

1. Delivers conditioned air at point of greatest heat loss and heat gain, which is the outside of the structure

(NOTE: These are points such as doors, windows, and exposed walls where heat loss and heat gain are greatest.)

2. Allows fewer air returns which are generally located in inner areas of structure
3. Delivers the highest level of heating comfort

B. Disadvantages of perimeter systems

1. More costly than many other systems
2. May be subject to water problems if ducts are buried under the slab

(NOTE: Floor level should be high enough that ducts are not below grade. PVC ducts are sometimes used to help avoid moisture problems.)

C. Advantages of high inside wall system

1. Supply outlets are located central to main trunk duct, so shorter ducts can be used
2. Pressure is less so smaller blower may be used
3. Doesn't interfere with furniture placement
4. Permits longer periods of blower operation
5. Well suited for cooling in areas where heating is of less importance
6. Less costly installation

D. Disadvantages of high inside wall systems

1. Heating is more difficult because of stratification
2. Areas of greatest heat loss and gain such as windows are difficult to condition unless special attention is paid to selection of registers

INFORMATION SHEET

- E. Advantages of low inside wall systems
 - 1. Supply outlets are located close to the blower
 - 2. Installation is less costly
 - F. Disadvantages of low inside wall systems
 - 1. Proper air distribution is difficult
 - 2. High air velocities must be avoided
 - 3. Furniture placement is difficult
 - 4. Difficult to use as a cooling system
 - 5. Diffuser vanes must be adjusted seasonally
 - G. Advantages of ceiling systems
 - 1. Doesn't interfere with furniture placement
 - 2. Can be located in center of room or near outside wall
 - 3. Well suited for summer cooling
 - 4. Return air can be located on either inside or outside wall, near the floor
 - H. Disadvantages of ceiling systems
 - 1. Proper selection of supply registers is critical
 - 2. May experience cold floors in cold climates
 - 3. Can cause room air stratification and large air temperature gradients
- VIII. Climatic zone conditions (Transparency 10)**
- A. Zone A
 - 1. Cold weather is more severe and more prolonged
 - 2. Summers are relatively mild
 - B. Zone B
 - 1. Less severe winters than zone A
 - 2. Hotter days for extended periods

INFORMATION SHEET

- C. Zone C
 - 1. Has mild winters
 - 2. Has hot summers
- D. Zone A1 — Has the characteristics of zone A except that summer temperatures are, on the average, higher than zone A

(NOTE: The Air Conditioning Contractors of America (ACCA) have three comfort ratings for air conditioning systems; the recommended level will provide occupants basic comfort requirements, the next lowest rating is acceptable, but the lowest rating is not acceptable.)

Example: A high inside wall supply is recommended in zone C, acceptable in zone B, but not acceptable in zones A-1 or A

IX. Air control devices and their applications

- A. **Damper** — Device used to vary the airflow rate through a duct, diffuser or register
- B. **Vane** — A fixed or adjustable device used to direct air flow
- C. **Grille** — A louvered or perforated covering of an inlet/outlet opening through which air flows
- D. **Register** — A combination grille and damper device covering an air inlet or outlet opening

X. Factors to consider in distribution of conditioned air

- A. Velocity of primary air
- B. Desired temperature of room air
- C. Proper sizing and location of grilles and registers to minimize noise and discomfort from drafts
- D. Velocity of air in duct system
 - 1. Trunk ducts 700-900 fpm
 - 2. Branch ducts 600-700 fpm

(NOTE: Because the sensation of drafts is greater with cold air, velocities of 25 to 35 fpm are recommended for an occupied space, but velocities from 20 to 50 fpm are acceptable; velocities lower than 15 fpm create stagnant air, and velocities over 65 fpm create uncomfortable drafts.)

INFORMATION SHEET

XI. Grille design factors and their meanings

- A. **Terminal velocity** — An arbitrary maximum velocity of an air stream which spreads or drops into a living area, usually considered comfortable at 50 fpm
- B. **Throw** — The distance an airstream travels after leaving a supply outlet before the velocity is reduced to the terminal velocity
- C. **Drop** — The distance air falls vertically below a high sidewall supply outlet before slowing to terminal velocity
- D. **Spread** — The maximum width of the total airstream at the point of terminal velocity
- E. **Primary air** — A mixture of supply air from an outlet and room air at velocities about 150 fpm
- F. **Entrained air** — Room air which is dragged into the primary air and raised to higher velocities inside the primary air envelope
- G. **Floor warming** — Floor heating by burying ducts in concrete slab floors or by running supply ducts under floors

XII. Outlet placement and their recommended velocities

- A. Floor diffusers — 450 fpm
- B. Baseboard diffusers — 700 fpm
- C. High sidewall registers — 350-500 fpm
- D. Low sidewall registers — 500 fpm

(NOTE: Inadequate velocity from any diffuser or register will cause primary cold air to drop into occupied space)

XIII. Air duct calculators

- A. Hand-held air duct calculators are handy for sizing ducts and for checking calculations. (Figure 1)

INFORMATION SHEET

FIGURE 1



- B. Air duct calculators can be used to size duct with the equal-friction method or the velocity reduction method.
- C. Air duct calculators are frequently stocked by dealers and distributors and may be available locally.
- D. The flip side of some calculators presents valuable information related to duct sizing and sometimes grille and register selection. (Figure 2)

FIGURE 2



Types of Supply Duct Systems

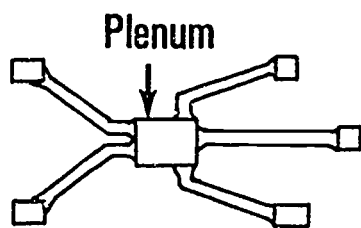

Radial or Spider

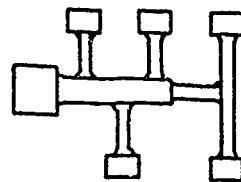

Trunk and Branch
Reducing Plenum

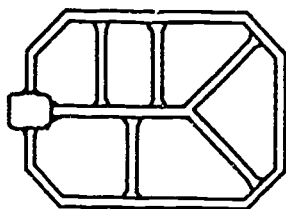

Perimeter Loop
Trunk Duct

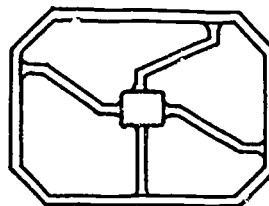

Perimeter Loop
Radial Duct

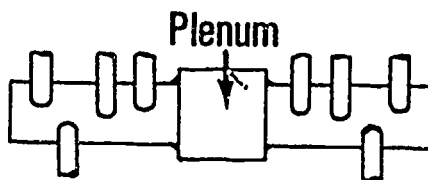

Trunk and Branch
Extended Plenum

Courtesy Air Conditioning Contractors of America

Equivalent Length and Effective Length of Fittings and Ducts

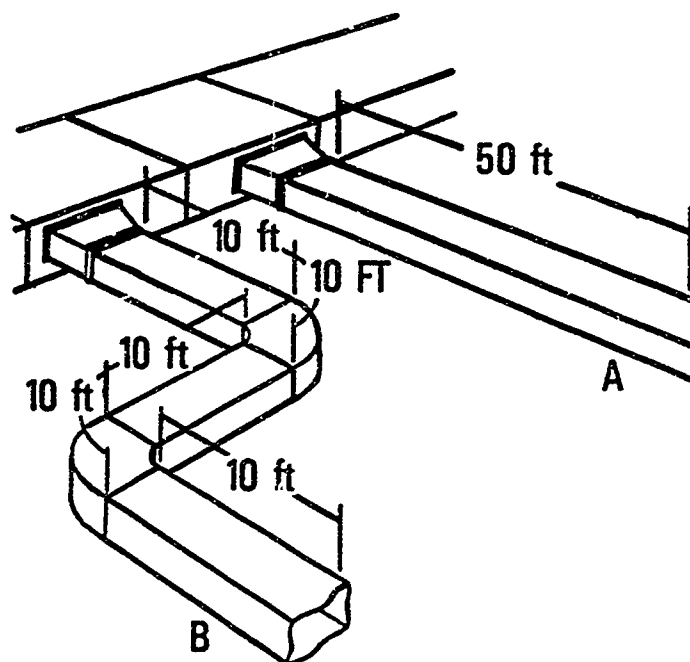

The effective length of Duct B is equal to the effective length of Duct A. The effective length of Duct B is obtained by adding equivalent length of fittings to actual measured duct length.

Courtesy Air Conditioning Contractors of America

Duct Fittings and Equivalent Lengths (Group 1)

Supply and Return Air Take-Off plenum Fittings (These Fittings May Also be Installed on Plenums for Counter Flow Units.)

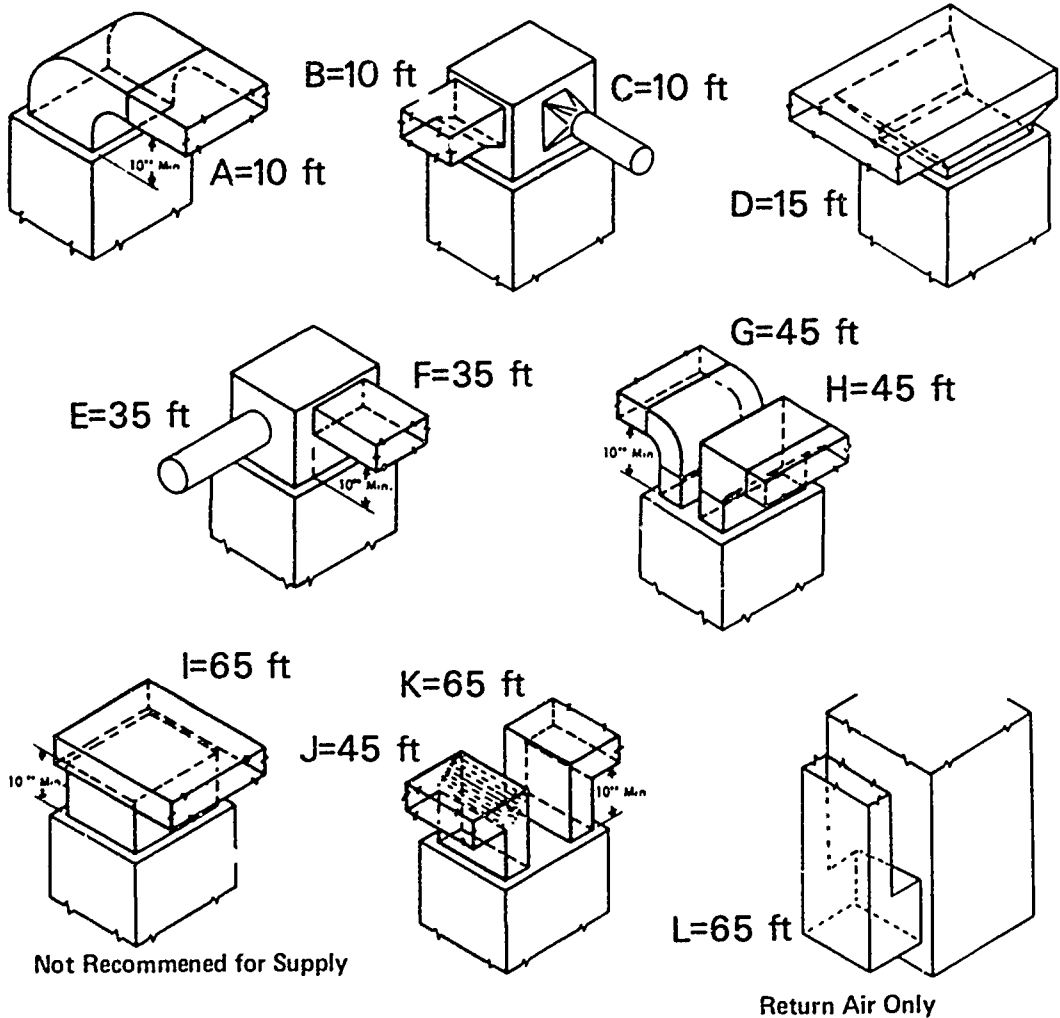

Courtesy Air Conditioning Contractors of America

Equivalent Lengths of Branch Take-off Fittings

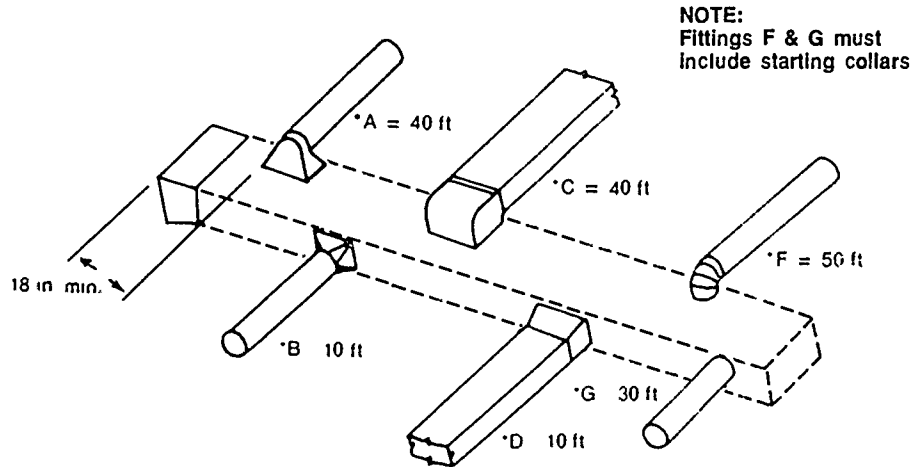

Example: given the system shown above, find the equivalent length for each branch takeoff fitting.
 Solution: see schedule below.

Branch	Basic Equiv. Length of Takeoff Fitting	No. of Branches Downstream	Added Equiv. Length	Final Equiv. Length
G	30	0	0	30
F	50	1	10	60
D	10	2	20	30
C	40	3	30	70
B	10	4	40	50
A	40	5	50	90

* Values shown above apply only when the branch is at the end of the trunk duct (ex., G above). For all other branches, add to the equivalent length shown ten feet (10 ft) times the number of branches downstream between the takeoff being evaluated and the end of the trunk duct.

Courtesy Air Conditioning Contractors of America

Duct Fittings and Equivalent Lengths

(Group 4)

Round Trunk Duct Fittings

(Add 25 equivalent feet to each of the 3 fittings nearest the unit in each truck duct)

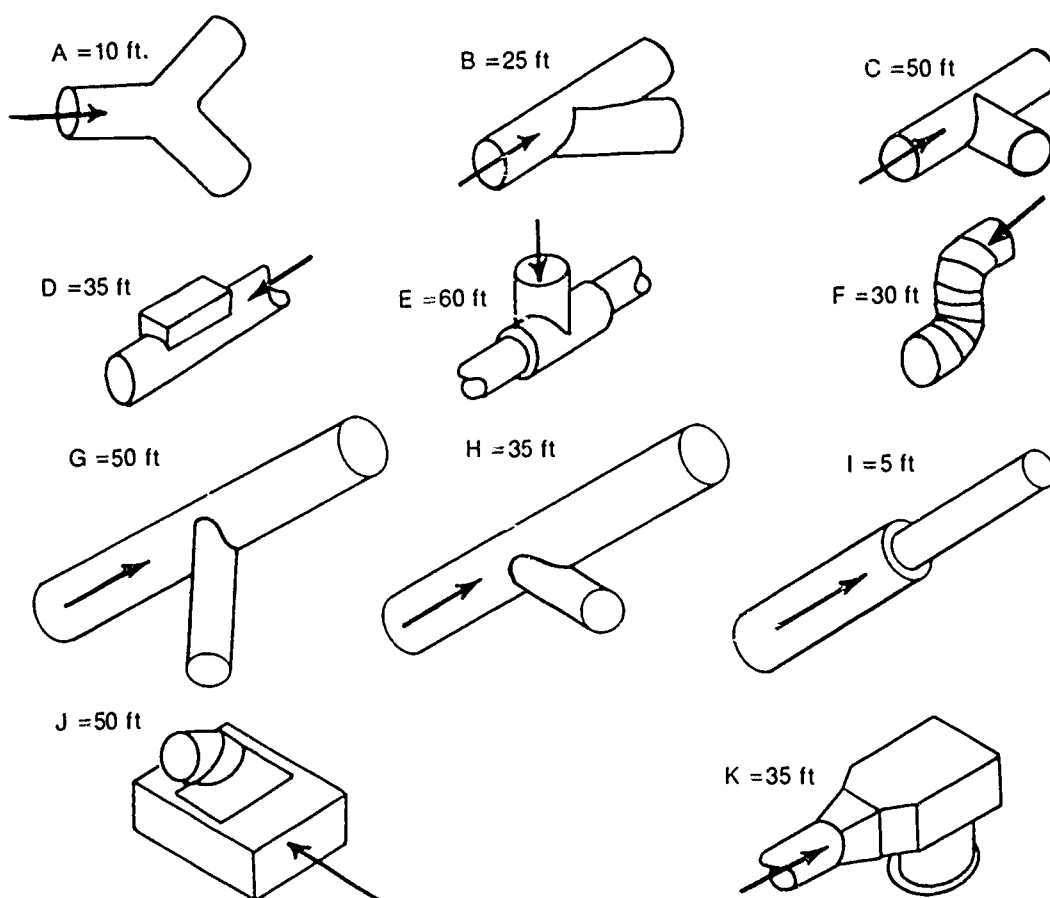

Drawings of Various Fittings with Equivalent Lengths Shown

Courtesy Air Conditioning Contractors of America

Duct Fittings and Equivalent Lengths

(Group 5)

Angles and Elbows for Trunk Ducts
(Inside Radius = 1/2 Width of Duct)



A Trunk Width Inches

4 to 15=5 ft
16 to 27=10 ft
28 to 41=15 ft
42 to 52=20 ft
53 to 64=25 ft

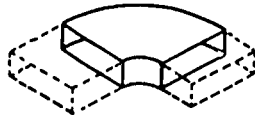

B Trunk Width Inches

4 to 11=10 ft
12 to 21=15 ft
22 to 27=20 ft
28 to 33=25 ft
34 to 42=30 ft
43 to 51=40 ft
52 to 64=50 ft

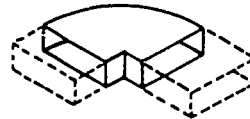

C Trunk Width Inches

4 to 6=20 ft
7 to 11=40 ft
12 to 15=55 ft
16 to 21=75 ft
22 to 27=100 ft
28 to 33=125 ft
34 to 42=150 ft

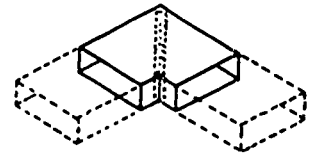

D Trunk Width Inches

4 to 11=15 ft
12 to 21=20 ft
22 to 27=25 ft
28 to 42=40 ft



E=5 ft



F=10 ft



G= 30 ft



H=15 ft



I=30 ft

Courtesy Air Conditioning Contractors of America

Duct Fittings and Equivalent Lengths

(Group 6)

Angles and Elbows For Individual and Branch Ducts
 Inside Radius for "A" and "B" = 3 in.
 and for "F" and "G" = 5 in.



A=5 ft



B=10 ft



C=25 ft



D=5 ft



E=10 ft



F=5 ft



G

10 in. wide=10 ft
 12 =15 ft
 14 =15 ft

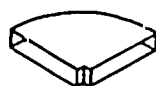

H

10 in. wide=40 ft
 12 =55 ft
 14 =55 ft



I

3/4 x 10 in.=60 ft
 1 1/2 =75 ft
 14 =75 ft



J

3/4 x 10 in.=75 ft
 12 =90 ft
 14 =90 ft

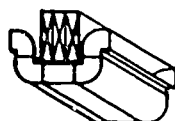

K=125 ft

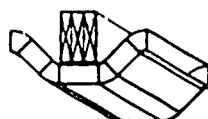

L=35 ft

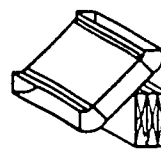

M=10 ft

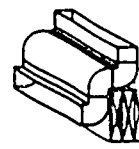

N=95 ft

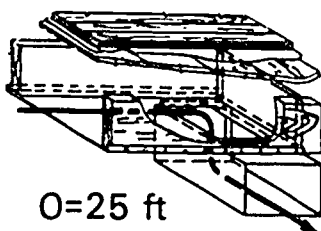

O=25 ft

Return Air Liner To Duct

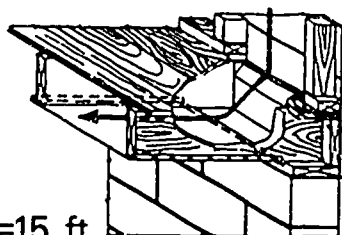

P=15 ft

Stud Spacer to Liner

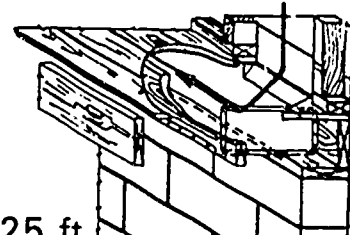

Q=25 ft

Stud Spacer To Liner

Drawings of Various Fittings with Equivalent Lengths Shown

Courtesy Air Conditioning Contractors of America

Duct Fittings and Equivalent Lengths

(Group 7)

Boot Fittings

(These values may also be used for floor diffuser boxes)

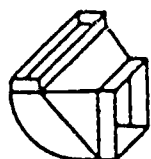

A=30 ft

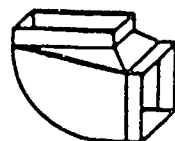

B=35 ft

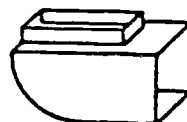

C=60 ft

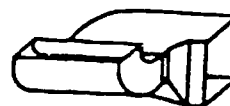

D=55 ft

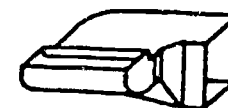

E=70 ft

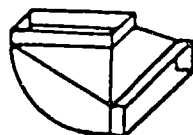

F=45 ft

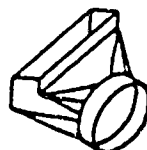

G=30 ft

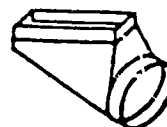

H=50 ft



I=5 ft

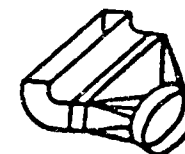

J=15 ft

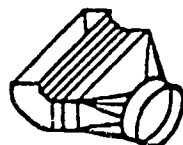

K=30 ft

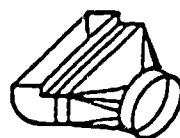

L=30 ft

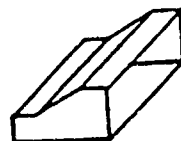

M=5 ft



N=15 ft

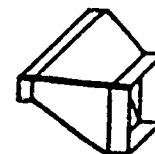

O=5 ft

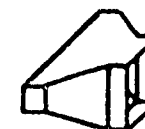

P=5 ft

Drawings of Various Fittings with Equivalent Lengths Shown

Courtesy Air Conditioning Contractors of America

Rectangular Duct Equivalents

Duct Diameter, In.	Equivalent Rectangular Stack and Duct Sizes, In.												
4.0													
4.5	8x2.25	4.5x3											
5.0	10x2.25	6x3											
			8x3.25	5x4	4x5					3x8			
5.5	12x2.25		10x3.25	7x4	5x5					4x8			
6.0	14x2.25		10x3.25	8x4	6x5					4x8			
6.5			12x3.25	9x4	7x5	6x6				5x8			
7.0			14x3.25	11x4	8x5	7x6				5x8			
7.5				13x4	10x5	8x6	7x7			6x8			
8.0				15x4	11x5	9x6	8x7			7x8			
8.5				17x4	13x5	10x6	9x7			8x8			
9.0				20x4	15x5	12x6	10x7			8x8			
9.5				22x4	17x5	13x6	11x7			9x8	8x9		
10.0				25x4	19x5	15x6	12x7	11x8	9x9				
10.5					21x5	16x6	14x7	12x8	10x9	9x10			
11.0					23x5	18x6	15x7	13x8	11x9	10x10			
11.5					26x5	20x6	17x7	14x8	12x9	11x10			
12.0					29x5	22x6	18x7	16x8	14x9	12x10			
12.5					32x5	24x6	20x7	17x8	15x9	13x10	11x12		
13.0					35x5	27x6	22x7	18x8	16x9	14x10	12x12		
13.5						30x6	24x7	20x8	17x9	16x10	13x12		
14.0						32x6	26x7	22x8	19x9	17x10	14x12		
14.5						35x6	28x7	24x8	20x9	18x10	15x12		
15.0						38x6	31x7	26x8	22x9	19x10	16x12	14x14	
15.5						41x6	33x7	28x8	24x9	21x10	17x12	14x14	
16.0						45x6	36x7	30x8	25x9	22x10	18x12	15x14	
16.5							38x7	32x8	27x9	24x10	19x12	16x14	
17.0							41x7	34x8	29x9	25x10	21x12	17x14	15x16
17.5							44x7	37x8	31x9	27x10	22x12	18x14	16x16
18.0								39x8	33x9	29x10	23x12	20x14	17x16
18.5								42x8	36x9	31x10	25x12	21x14	18x16
19.0								45x8	38x9	33x10	26x12	22x14	19x16
19.5								47x8	41x9	35x10	28x12	23x14	20x16
20.0								51x8	43x9	37x10	29x12	25x14	21x16

Courtesy Air Conditioning Contractors of America

Climatic Zone Map for System Selection

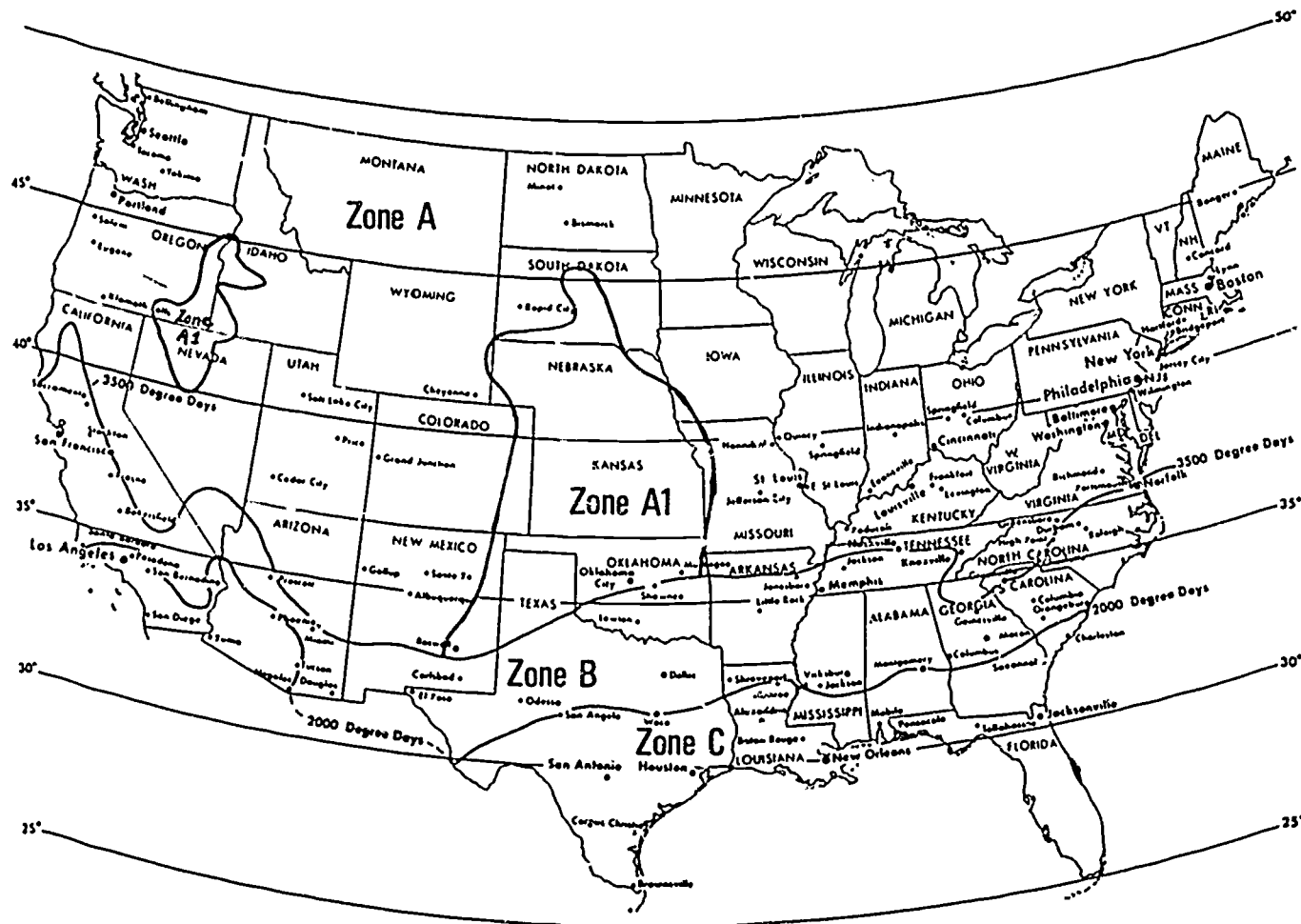

Courtesy Air Conditioning Contractors of America

Supply and Return Air System Characteristics

SYSTEM CHARACTERISTICS	SUPPLY	RETURN
Returns at equipment	90%	10%
Single return near equipment	80%	20%
Single return with appreciable return duct run	70%	30%
Multiple return with moderate return duct system	60%	40%
Multiple return with extensive return duct system	50%	50%

Courtesy Air Conditioning Contractors of America

Friction Chart

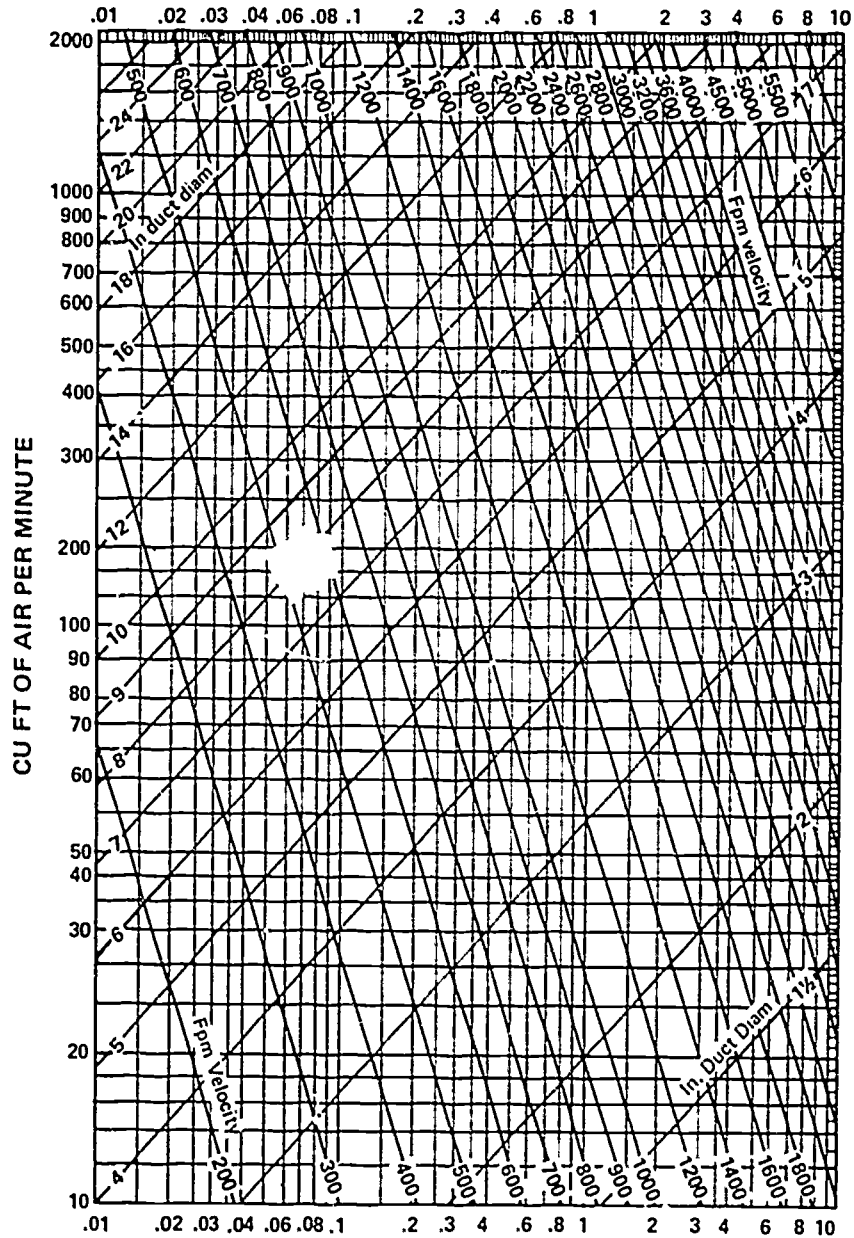

Friction Loss in Inches of Water Per 100 Ft

(Based on Standard Air of 0.075 lb per cu ft density flowing through average, clean round, galvanized metal ducts having approximately 40 joints per 100 ft.)

Caution: Do not extrapolate below chart.

Courtesy Air Conditioning Contractors of America

Friction Chart — Flexible, Vinyl Coated Helix Core Ducts

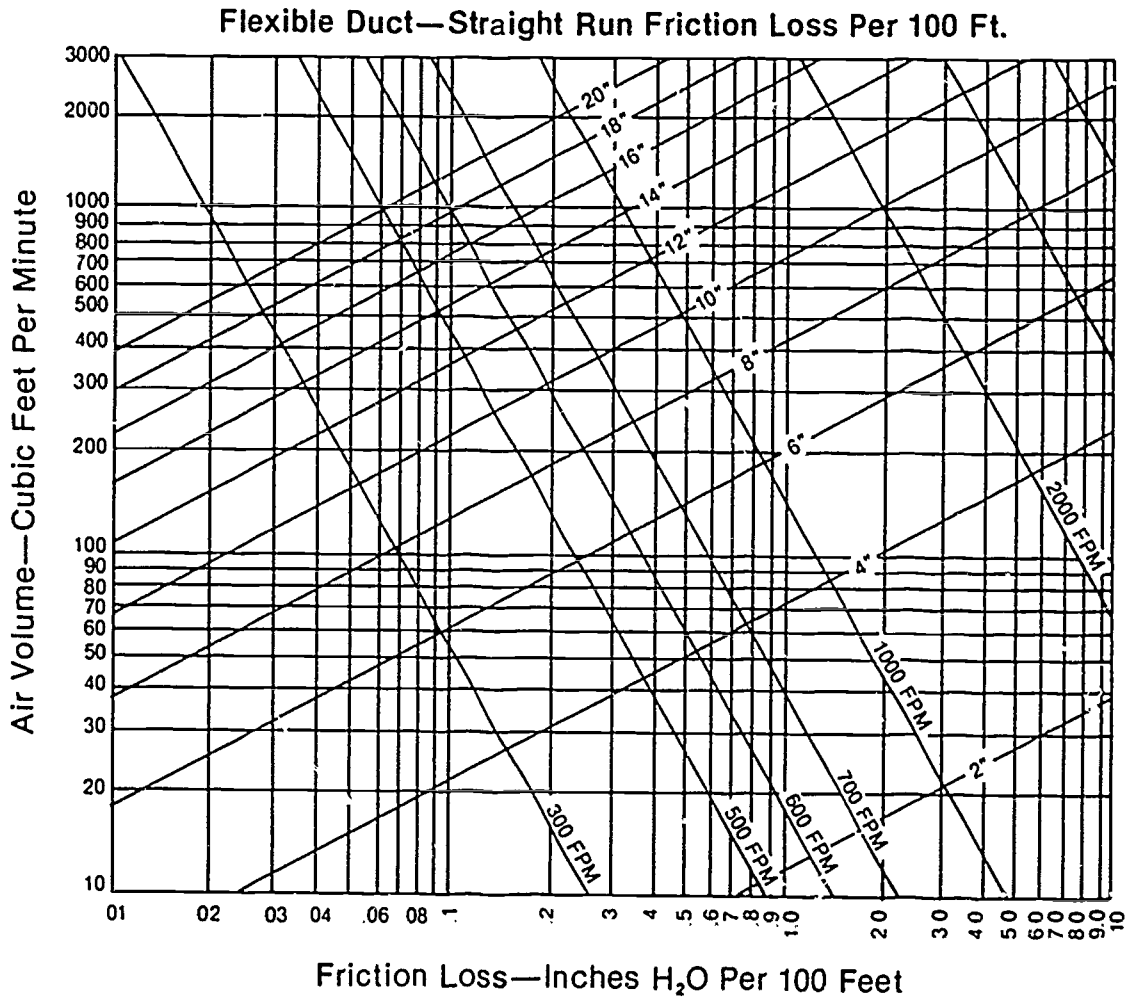

Courtesy Air Conditioning Contractors of America

**RESIDENTIAL DUCT DESIGN AND SIZING
UNIT III**

**ASSIGNMENT SHEET #1 — SOLVE PROBLEMS USING THE
FRICTION CHART FOR SHEET METAL DUCT**

Directions: Use the Friction Chart in TM 12 to calculate duct size and air velocity for the conditions given.

	CFM	Friction Loss per 100 ft	Duct Diameter	Velocity Ft/Mn
1.	98	.02	_____	_____
2.	210	.03	_____	_____
3.	125	.08	_____	_____
4.	400	.20	_____	_____
5.	500	.20	_____	_____
6.	55	.07	_____	_____
7.	80	.15	_____	_____
8.	500	5.00	_____	_____
9.	100	.6	_____	_____
10.	1400	.015	_____	_____
11.	1000	.02	_____	_____
12.	500	.03	_____	_____
13.	200	.05	_____	_____
14.	2000	3.5	_____	_____

**RESIDENTIAL DUCT DESIGN AND SIZING
UNIT III**

**ASSIGNMENT SHEET #2 — SOLVE PROBLEMS USING
THE FRICTION CHART FOR FLEX DUCT**

Directions: Use the Friction Chart in TM 13 to calculate duct size and air velocity for the flex duct conditions given.

	CFM	Friction Loss per 100 ft	Duct Diameter	Velocity Ft/Mn
1.	98	.02	_____	_____
2.	210	.03	_____	_____
3.	125	.08	_____	_____
4.	400	.20	_____	_____
5.	500	.20	_____	_____
6.	55	.07	_____	_____
7.	80	.15	_____	_____
8.	500	5.00	_____	_____
9.	100	.6	_____	_____
10.	1400	.015	_____	_____
11.	1000	.02	_____	_____
12.	500	.03	_____	_____
13.	200	.05	_____	_____
14.	2000	3.5	_____	_____

RESIDENTIAL DUCT DESIGN AND SIZING UNIT III

ASSIGNMENT SHEET #3 — DESIGN AN AIR DISTRIBUTION SYSTEM FROM A DRAWING

Directions: Use your load calculations made for the residence in Unit II to get started with your air distribution design. Figures 1 and 2 that accompany this assignment sheet provide you with the supply and return duct systems for the same residence you worked with in Unit II. Reference both figures as needed as you complete the attached Form D-1 Worksheet, the Form D-2 duct sizing form, and the equivalent length form. Check with your instructor if you run into problems or have questions about designing an air distribution system. Be sure to reference Figure 3 to see what installed ducts will look like.

1. Select the proper size heating and cooling equipment for the residence used in Unit II.
2. On the right hand side of Form D-1, record the total SENSIBLE gain on line A and the total heat loss on line B.
3. Enter the blower CFM on line C

(NOTE: Some manufacturers do not publish performance data which specifies both sensible and latent capacity at various design conditions. In this case the approximate design CFM can be estimated by using the following table)

<p style="text-align: center;">Very Humid Climates Low Daily Temperature Range-Less than 15 Degrees (Min.) 360 CFM per 12,000 BTUH total cooling capacity</p>
<p style="text-align: center;">Moderately Humid Climates Medium Daily Temperature Range-15 to 25 degrees (Min.) 440 CFM per 12,000 BTUH total cooling capacity</p>
<p style="text-align: center;">Dry Climates High Daily Temperature Range-More than 25 degrees (Min.) 530 CFM per 12,000 BTUH total cooling capacity</p>

4. Enter the available static pressure on line D.
5. Calculate and enter the heating air flow factor (HF) in block E, and also in block 8 on the left hand side of the page.
6. Calculate and enter the cooling air flow factor (CF) in block F, and also in block 10 on the left hand side of the page.

ASSIGNMENT SHEET #3

7. Calculate and enter the temperature rise through the furnace in block 5.
(NOTE: If it is not within the manufacturer's specifications you will have to use a different blower speed.)
8. In block H enter the pressure loss of each item listed to arrive at the total loss.
(NOTE: Usually a value of .03 IWG pressure drop for both the supply registers and return grilles can be assumed.)
9. In block I enter the available static pressure (D) and subtract the total loss (H) arriving at the duct system design static.
10. In block J enter the duct system design static and assign the proper amount to the supply, and also, enter in line 12 on the left hand side of the page.
11. In block K enter the duct design static (I) and assign the proper amount to the return, and also, enter in line 24 on the left hand side of the page.
12. Using the room by room load "J-Sheet" from unit II, locate the supply air outlets.
(NOTE: Use at least one outlet for each 8,000 BTUH of room heat loss or 4,000 BTUH of room SENSIBLE heat gain.)
13. On form D-1 enter the trunk duct identification letter in line 1 showing the outlet number it serves.
14. In line 2 enter the name of the area the outlet supplies.
15. In line 3, enter the measured length of run-out (branch) in feet.
16. In line 4, enter the measured length of trunk duct in feet.
17. In line 5, enter the equivalent length of fittings (use form D-2).
18. By adding lines 3, 4, and 5 enter the total effective length in line 6.
19. Enter total heat loss for each area in line 7.
(NOTE: If more than one outlet serves the same area the amount is divided between them.)
20. Calculate and enter the heating CFM in line 8.
21. Enter the SENSIBLE cooling for each area in line 9.
22. Calculate and enter the cooling CFM in line 10.
23. Enter the larger CFM of the two in line 11.
24. Calculate the branch design static and enter in line 12.

ASSIGNMENT SHEET #3

25. Using the "friction loss chart" for straight sheetmetal ducts, find the velocity (enter in line 13) and the calculated duct size (enter in line 14).

(NOTE: If the velocity is too high, the duct size should be increased.)
 26. Enter the recommended standard size in line 15 (Grilles and registers will be selected later).
 27. Use the same procedures to size the return ducts working lines 20 through 27 (Divide the return CFM equally between the two).
 28. Use Form D-2 to determine the supply trunk duct and the supply plenum riser sizes.
 29. Enter the trunk identifying letter "A" in the designated space.
 30. Record the identification numbers of the outlets served by that trunk in column "A".
 31. Transfer the information asked for each outlet from D-1, to form D-2 (Heating CFM, cooling CFM, and adjusted static).
 32. Total the heat and cool CFM columns, draw a line through the smaller, using the larger CFM to determine the trunk duct size.
 33. Examine the adjusted static loss (column C) and select the smallest value, entering it in the "trunk duct design static" line. This is the static pressure used for the trunk duct sizing.
 34. Use the friction loss chart to determine the proper size return duct.
 35. Repeat the above for trunk "B" and the supply riser ("C").
 36. Use the grille manufacturer specifications to select supply and return grilles.

(NOTE: Refer to manual D for recommended procedures for selection being careful to keep face velocity at a quiet level)
- Have your instructor evaluate your air distribution design.

ASSIGNMENT SHEET #3

FIGURE 1

Supply Duct System

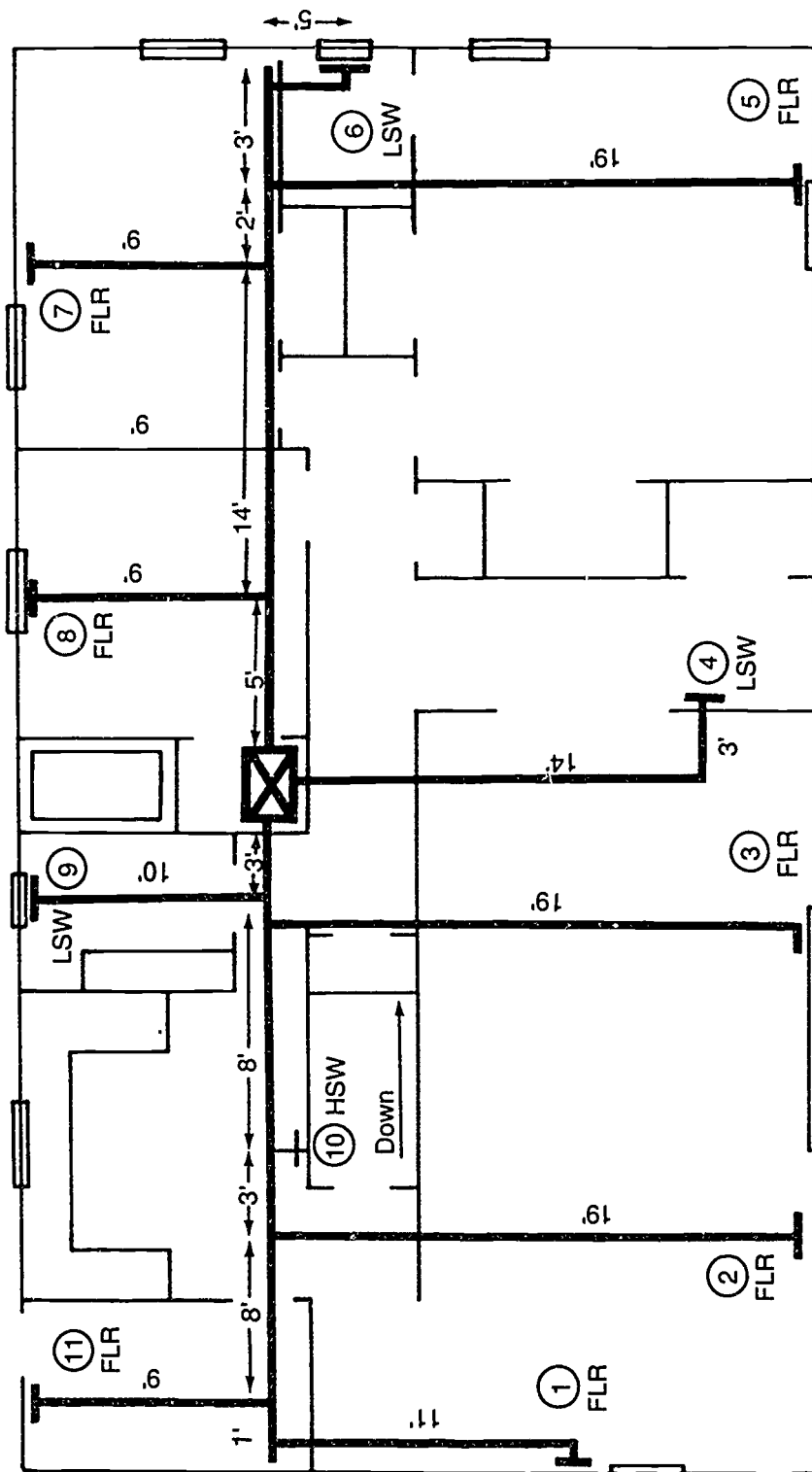

ASSIGNMENT SHEET #3

FIGURE 2 Return Duct System

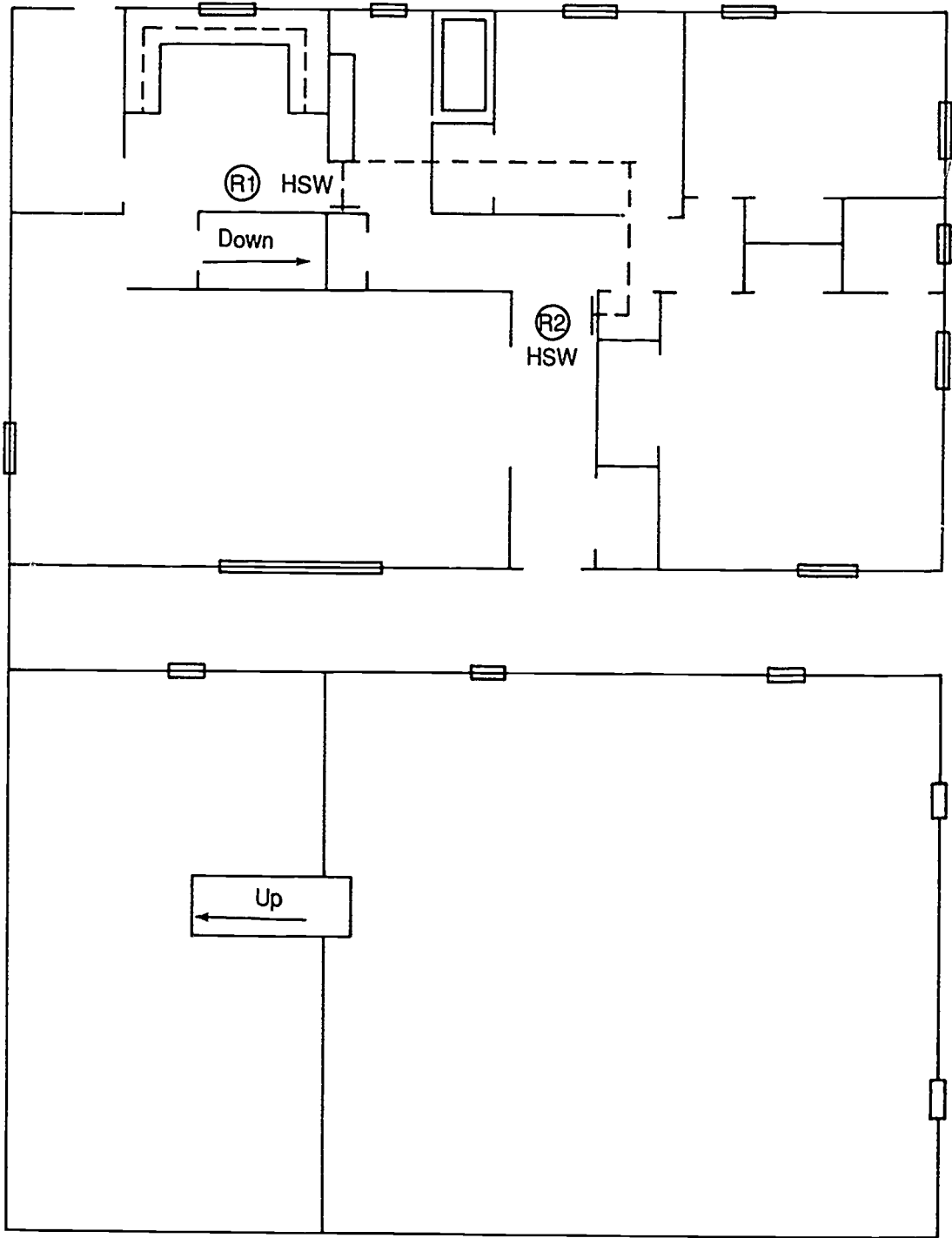

ASSIGNMENT SHEET #3

FIGURE 3 Duct Run Examples

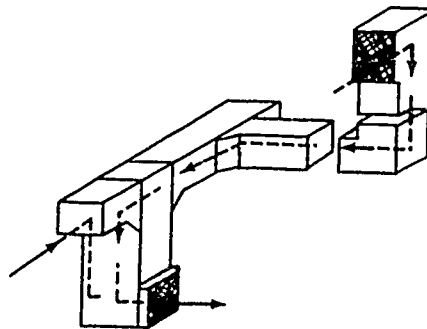
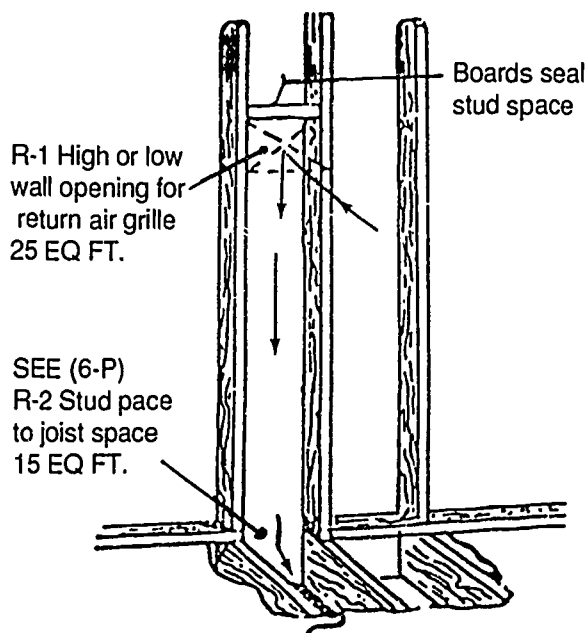
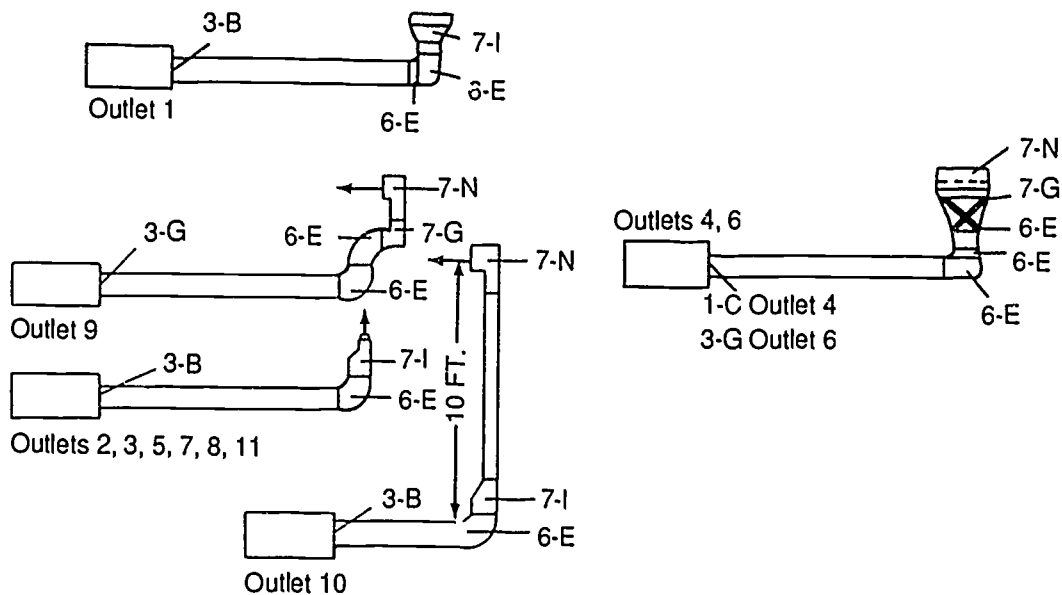

Courtesy Air Conditioning Contractors of America

ASSIGNMENT SHEET #3

**FORM D-1
WORKSHEET FOR MANUAL D**

Trunk and/or Branch Duct Sizing for:
 Extended Plenum Systems
 Reducing Trunk Systems
 Radial Systems
 Flexible Duct Systems
 Stack and Register or Diffuser Sizing,
 Return-Branch, Stack and Intake Grille Sizing

For: Name _____
 Address _____
 City _____

By: Contractor _____
 Address _____
 City _____

Heating Information

(Insert data below only after all heat loss calculations have been completed)

Total Heat Loss (BTUh) _____ (From Manual J, J1 Form Model No. _____
 Line No. 15.)
 Serial No. _____ Manufactured by _____
 Rating Data: Input _____ BTUh Output at Bonnet _____ BTUh
 Description of Controls _____

Cooling Information

(Insert data below only after all heat gain calculations have been completed)

Total Sensible Gain (BTUh) _____ (From Calculation Procedure D, Manual J, J1 Form.)
 Equipment Type _____ Model No. _____
 Serial No. _____ Manufactured by _____
 Rating Data: Cooling Capacity _____ BTUh Air Volume _____ Cfm
 Description of Controls _____

FILE _____

Courtesy Air Conditioning Contractors of America

ASSIGNMENT SHEET #3

FORM D-1		SUPPLY - BRANCH, STACK, and REGISTER SIZING														RETURN - BRANCH, STACK, and INTAKE SIZING													
1	2	3	4	5	6	7	8	9	10	11	12	13	14	15	16	17	18	19	20	21	22	23	24	25	26	27	28	29	
Outlet Number	Trunk Serving Outlet																												
2	Name of Area																												
3	Measured Length of RUN-OUT (FT)																												
4	Measured Length of Trunk Duct (FT)																												
5	Equivalent Length of Fittings (From Form D-2)																												
6	Total Effective Length of Run (3 + 4 + 5)																												
7	Total Heating BTUH (From Form J-1)																												
8	Heating CFM (HP) (See E)																												
9	Total Branch Cooling BTUH (From Form J-1)																												
10	Cooling CFM (CP) (See F)																												
11	Higher CFM (Hig or Cld)																												
12	Branch Design TRS (TD) (See J)																												
13	Required Air Flow (CFM) (See J)																												
14	Round Duct Size - (Consult Duct Chart or Ductcalc)																												
15	Round Duct Size - Recommended (Use Standard Sizes)																												
16	Rectangular Duct Size (Use Table A-11 or Ductcalc)																												
17	Location of Duct (Required)																												
18	Notes (Check for load drop)																												
Special Instructions																													
19	Inlet Number	R1	R2	R3	R4	R5	R6	R7	R8	R9	R10	R11	R12	R13	R14														
20	Measured Length of Duct Run (FT) (From Return to Inlet)																												
21	Approved Length of Fittings (From Form D-2)																												
22	Total Effective Length of Run (20 + 21)																												
23	Return CFM																												
24	Return Design TRS (TD) (See K)																												
25	Velocity of the Return Air (Should not exceed 1500 FPM for 100 ft. or less)																												
26	Required Air Flow (CFM) (See K)																												
27	Standard Round Duct Size or Rectangular Duct Size																												
28	Return Grille Free Area																												
29	Return Grille Size (See Manufacturer's Data)																												

FORM D-1 INFORMATION

A. Total Branch Heat Gain
 B. Total Heat Loss
 C. Return CFM
 D. Avoid Excessive Bal. Press.
 E. Heating Air Flow Factor
 HP = Branch CFM (C)
 Total Heat Loss (B)
 HP = _____ (enter on Item 8)
 (enter on Item 8)

F. Cooling Air Flow Factor
 CP = Branch CFM (C)
 Total Branch Heat Gain (A)
 CP = _____ (enter on Item 10)
 (enter on Item 10)

G. Temperature Rise
 TD = Furnace and/or BTUH
 11% Blower CFM
 TD = _____

H. Duct System Design Factors
 Supply Register
 Return Grille
 Cooling Coil
 FC or
 Other Components
TOTAL LOSSES
 I. Duct System Design Loads
 Avoid Short Press (D)
 Avoid Short Press (E)
DUCT SYSTEM STAT
 J. Supply System Design Loads
 Duct System Stat (I)
 (Round % to Supply)
TOTAL SUPPLY STAT
 (Round on Item 12)
 K. Return System Design Loads
 Duct System Stat (I)
 (Round % to Return)
TOTAL RETURN STAT
 (Round on Item 21)

Courtesy Air Conditioning Contractors of America



ASSIGNMENT SHEET #3

Trunk Duct Sizing
Form D-2

Outlet or Inlet No. or Trunk Letter	Supply CFM or Return CFM			Adjusted Static Press. Loss in wg. (in/f)	
	Trunk _____				
	A	B			C
		Heat	Cool		
Total CFM					
Trunk Design Static Use Lowest in Col. C					
Round Duct Size in					
Rectangular Duct Size					
Trunk Velocity *					

Outlet or Inlet No. or Trunk Letter	Supply CFM or Return CFM			Adjusted Static Press. Loss in wg. (in/f)	
	Trunk _____				
	A	B			C
		Heat	Cool		
Total CFM					
Trunk Design Static Use Lowest in Col. C					
Round Duct Size in					
Rectangular Duct Size					
Trunk Velocity *					

Outlet or Inlet No. or Trunk Letter	Supply CFM or Return CFM			Adjusted Static Press. Loss in wg. (in/f)	
	Trunk _____				
	A	B			C
		Heat	Cool		
Total CFM					
Trunk Design Static Use Lowest in Col. C					
Round Duct Size in					
Rectangular Duct Size					
Trunk Velocity *					

Outlet or Inlet No. or Trunk Letter	Supply CFM or Return CFM			Adjusted Static Press. Loss in wg. (in/f)	
	Trunk _____				
	A	B			C
		Heat	Cool		
Total CFM					
Trunk Design Static Use Lowest in Col. C					
Round Duct Size in					
Rectangular Duct Size					
Trunk Velocity *					

Courtesy Air Conditioning Contractors of America

ASSIGNMENT SHEET #3

EQUIVALENT LENGTHS OF FITTINGS

FTG.	E.L.	FTG.	E.L.	FTG.	E.L.	FTG.	E.L.	FTG.	E.L.	FTG.	E.L.	FTG.	E.L.	FTG.	E.L.	FTG.	E.L.
Total		Total		Total		Total		Total		Total		Total		Total		Total	

*NOTE: Branch/Plenum Velocity Factor, Add to each take-off,
10 times the number of down stream take-offs (See Chart A6, Group 3)

FTG.	E.L.	FTG.	E.L.	FTG.	E.L.	FTG.	E.L.	FTG.	E.L.	FTG.	E.L.	FTG.	E.L.	FTG.	E.L.	FTG.	E.L.
Total		Total		Total		Total		Total		Total		Total		Total		Total	

Identify fitting by Group Number and Letter shown in Fig. 6.8 Manual D.

Courtesy Air Conditioning Contractors of America

**RESIDENTIAL DUCT DESIGN AND SIZING
UNIT III**

ANSWERS TO ASSIGNMENT SHEETS

Assignment Sheet #1

	CFM	Friction Loss per 100 ft	Duct Diameter	Velocity Ft/Mn
1.	98	.02	<u>9</u>	<u>300</u>
2.	210	.03	<u>10</u>	<u>400</u>
3.	125	.08	<u>7</u>	<u>550</u>
4.	400	.20	<u>8.5</u>	<u>1000</u>
5.	500	.20	<u>9.3</u>	<u>1075</u>
6.	55	.07	<u>5.3</u>	<u>400</u>
7.	80	.15	<u>5.5</u>	<u>630</u>
8.	500	5.00	<u>4.9</u>	<u>3800</u>
9.	100	.6	<u>4.8</u>	<u>1200</u>
10.	1400	.015	<u>23</u>	<u>500</u>
11.	1000	.02	<u>19</u>	<u>500</u>
12.	500	.03	<u>13.5</u>	<u>500</u>
13.	200	.05	<u>8.9</u>	<u>490</u>
14.	2000	3.5	<u>8.9</u>	<u>4750</u>

ANSWERS TO ASSIGNMENT SHEETS

Assignment Sheet #2

	CFM	Friction Loss per 100 ft	Duct Diameter	Velocity Ft/Mn
1.	98	.02	<u>11.5</u>	<u>200 est</u>
2.	210	.03	<u>12.5</u>	<u>280 est</u>
3.	125	.08	<u>8.1</u>	<u>320</u>
4.	400	.20	<u>11</u>	<u>650</u>
5.	500	.20	<u>12</u>	<u>675</u>
6.	55	.07	<u>6.1</u>	<u>290 est</u>
7.	80	.15	<u>6.1</u>	<u>400</u>
8.	500	5.00	<u>6.1</u>	<u>2500 est</u>
9.	100	.6	<u>5.25</u>	<u>700</u>
10.	1400	.015	<u>20+</u>	<u>290</u>
11.	1000	.02	<u>20+</u>	<u>300</u>
12.	500	.03	<u>17.5</u>	<u>310</u>
13.	200	.05	<u>11</u>	<u>310</u>
14.	2000	3.5	<u>11.25</u>	<u>2000+ est</u>

ANSWERS TO ASSIGNMENT SHEETS

Assignment Sheet #3

**FORM D-1
WORKSHEET FOR MANUAL D**

Trunk and/or Branch Duct Sizing for:
 Extruded Plenum Systems
 Reducing Trunk Systems
 Radial Systems
 Flexible Duct Systems
 Stack and Register or Diffuser Sizing,
 Return-Branch, Stack and Intake Grille Sizing

For: Name _____
 Address _____
 City _____
 By: Contractor _____
 Address _____
 City _____

Heating Information

(Insert data below only after all heat loss calculations have been completed)

Total Heat Loss (BTUh) 39,637 (From Manual J, J1 Form Model No. _____
 Line No. 15.)
 Serial No. _____ Manufactured by _____
 Rating Data. Input 60,000 BTUh Output at Bonnet 48,000 BTUh
 Description of Controls _____

Cooling Information

(Insert data below only after all heat gain calculations have been completed)

Total Sensible Gain (BTUh) 21,276 (From Calculation Procedure D, Manual J, J1 Form.)
 Equipment Type _____ Model No. _____
 Serial No. _____ Manufactured by _____
 Rating Data. Cooling Capacity 28,500 BTUh Air Volume (MED-HI) 1000 Cfm
 Description of Controls _____

FILE _____

Assignment Sheet #3 (Continued)

ANSWERS TO ASSIGNMENT SHEETS

FORM D-1 SUPPLY - BRANCH, STACK, and REGISTER SIZING																	FORM D-1 INFORMATION		
1	Outlet Number	Trunk Serving Outlet	1 A	2 A	3 A	4 C	5 B	6 B	7 B	8 B	9 A	10 A	11 A	12 C	13	14	A	B	C
2	Name of Area		LIVING	AND DINING	HALL	BR #1	BATH #2	BR #2	BR #3	BATH #1	KIT	UTILITY	REC.				Total Sensible Heat Gain	30262	
3	Measured Length of RUN OUT (FT)		11	19	19	17	19	5	9	9	10	10	9				Total Heat Loss	3163.7	
4	Measured Length of Trunk Inlet (FT)		24	15	4	-	21	24	19	5	3	12	23				Blower CFM	1000	
5	Equivalent Length of Fittings (from Form D-2)		45	55	75	85	70	140	80	90	155	80	45				Aval External Stat Pres	50	
6	Total Effective Length of Run (L = L + Σ)		80	89	98	102	110	169	108	104	168	94	77				F Heating Air Flow Factor		
7	Total Heating BTU/h (from Form J-1)		3117	3117	3117	2472	4919	894	4489	2245	1220	2184	2403	9454			H Blower CFM (C)		
8	Heating CFM (HF X Line #)	HF 0.28 (See P. 2)	80	80	80	62	123	22	112	56	31	55	60	236			Total Heat Loss (B)		
9	Total Sensible Cooling BTU/h (from Form J-1)		2208	2208	2208	881	2614	387	2382	1424	737	2293	730	2187			I Blower CFM (C)		
10	Cooling CFM (CF X Line #)	CF 0.24 (See P. 2)	108	108	108	43	128	19	117	70	36	112	36	107			Total Sensible Heat Gain (A)		
11	Higher CFM (Htg or C) Line # or 1		108	108	108	62	128	22	117	70	36	112	60	236			C Blower CFM (C)	1000	019
12	Branch Design Temp (T _{stat}) Line #		14	12	11	11	10	07	10	11	07	12	14				20265		
13	Velocity of the Air FPM (should not exceed 900 FPM 400 Rec.)		675	675	675	580	600	330	385	530	360	360	375	440			G Temperature Rise		
14	Round Duct Size (calculated) (Use Chart on Ductwork)		6.4	6.7	6.8	5.1	7	3.7	6.9	5.5	4.6	6.6	4.8				T Blower output BTU/h (1.1 x Blower CFM)		
15	Round Duct Size (Recommended) (Use Standard Sizes)		7	7	7	5	7	4	7	6	5	7	5				T Blower output BTU/h (1.1 x 1000)	48000	43
16	Rectangular Duct Size (Use Table A II of Handbook)																H Duct System Pressure Losses		
17	Location of Outlet	Required Throw	FLR 6	FLR 6	FLR 6	LSW 6	FLR 6	LSW 6	FLR 6	FLR 6	LSW 6	HSN 8	FLR 6				Supply Registers	03	
18	Register or Diffuser Size (Check throw and drop)																Return Grilles	03	
19	Special Instructions																Cooling Coils	25	
RETURN - BRANCH, STACK, and INTAKE SIZING																			
19	Inlet Number	Return Trunk Letter	R1	R2	R3	R4	R5	R6	R7	R8	R9	R10	R11	R12	R13	R14			
20	Measured Length of Duct Run (FT) (from Blower to Inlet)		17	25															
21	Equivalent Length of Fittings (from Form D-2)		140	140															
22	Total Effective Length of Run (L = L + Σ)		157	165															
23	Return CFM		500	500															
24	Return Design Temp. (T _{stat}) Line #	DB (See P. 2)	05	05															
25	Velocity of the Return Air (should not exceed 700 fpm - 500 fpm recommended)		625	625															
26	Round Duct Size (calculated) (Use Chart on Ductwork)		12.1	12.1															
27	Standard Round Duct Size (Use Manufacturer's Data)		12	12															
28	Return to Free Area																		
29	Return to Return (Use Manufacturer's Data)																		
			Supply Outlet Model No.	CFR FJR	HSW LSW	Return Inlet Model No.	CFR FJR	HSW LSW	Manufacturer								J Supply System Design Static Duct System Static (return to Supply) TOTAL SUPPLY STATIC (round on line 2) K Return System Design Static Duct System Static (return to Return) TOTAL RETURN STATIC (round on line 2)		

166

167

ANSWERS TO ASSIGNMENT SHEETS

Assignment Sheet #3 (Continued)

Trunk Duct Sizing
Form D-2

Outlet or Inlet No. or Trunk Letter	Supply CFM or Return CFM		Adjusted Static Press. Loss in wg. (in ft)
	Heat	Cool	
<u>Trunk A</u>			
A	80	108	.14
2	80	108	.12
3	80	108	.11
9	31	36	.07
10	55	112	.12
11	60	36	.14
Total CFM			386 (508)
Trunk Design Static Use Lowest in Col. °C			.07
Round Duct Size in			11.8 12
Rectangular Duct Size			16x8
Trunk Velocity *			700 640

Outlet or Inlet No. or Trunk Letter	Supply CFM or Return CFM		Adjusted Static Press. Loss in wg. (in ft)
	Heat	Cool	
<u>Trunk B</u>			
5	123	128	.10
6	22	19	.07
7	112	117	.10
8	56	70	.11
Total CFM			313 (334)
Trunk Design Static Use Lowest in Col. °C			.07
Round Duct Size in			9.8 10
Rectangular Duct Size			11x8
Trunk Velocity *			675 600

Outlet or Inlet No. or Trunk Letter	Supply CFM or Return CFM		Adjusted Static Press. Loss in wg. (in ft)
	Heat	Cool	
<u>Trunk C SUPPLY RISER</u>			
A	386	508	.07
B	313	334	.07
4	62	43	.11
12	236	107	
Total CFM			997 (992)
Trunk Design Static Use Lowest in Col. °C			.07
Round Duct Size in			15 16
Rectangular Duct Size			15x14
Trunk Velocity *			630 600

Outlet or Inlet No. or Trunk Letter	Supply CFM or Return CFM		Adjusted Static Press. Loss in wg. (in ft)
	Heat	Cool	
<u>Trunk RA</u>			
R1	500	500	.05
R2	500	500	.05
Total CFM			1000 (1000)
Trunk Design Static Use Lowest in Col. °C			.05
Round Duct Size in			16
Rectangular Duct Size			15x14
Trunk Velocity *			725

ANSWERS TO ASSIGNMENT SHEETS

Assignment Sheet #3 (Continued)

EQUIVALENT LENGTHS OF FITTINGS

1		2		3		4		5		6		7		8		9	
FTG.	E.L.	FTG.	E.L.	FTG.	E.L.	FTG.	E.L.	FTG.	E.L.	FTG.	E.L.	FTG.	E.L.	FTG.	E.L.	FTG.	E.L.
1-B	10	1-B	10	1-B	10	1-C	10	1-F	35	1-F	35	1-F	35	1-F	35	1-B	10
3-B	10	3-B	10	3-B	10	6-E	10	3-B	10	3-G	30	3-B	10	3-B	10	3-G	30
6-E	10	6-E	10	6-E	10	6-E	10	6-E	10	6-E	10	6-E	10	6-E	10	6-E	10
6-E	10	7-I	5	7-I	5	6-E	10	7-I	5	6-E	10	7-I	5	7-I	5	6-E	10
7-I	5					7-G	30			6-E	10					7-G	30
						7-N	15			7-G	30					7-N	15
		VEL. FACTOR	20	VEL. FACTOR	40			VEL. FACTOR	10	7-N	15	VEL. FACTOR	20	VEL. FACTOR	30	VEL. FACTOR	50
Total	45	Total	55	Total	75	Total	85	Total	70	Total	140	Total	80	Total	90	Total	155

*NOTE: Branch/Plenum Velocity Factor, Add to each take-off.
10 times the number of down stream take-offs (See Chart A6, Group 3)

10		11						R#1		R#2							
FTG.	E.L.	FTG.	E.L.	FTG.	E.L.	FTG.	E.L.	FTG.	E.L.	FTG.	E.L.	FTG.	E.L.	FTG.	E.L.	FTG.	E.L.
1-B	10	1-B	10					1-L	65	1-L	65						
3-B	10	3-B	10					1-B	10	1-B	10						
6-E	10	6-E	10					3-D	10	3-D	10						
7-I	5	7-I	5					5-I	30	5-I	30						
7-N	15							8-R1	25	8-R1	25						
VEL. FACTOR	30	VEL. FACTOR	10														
Total	80	Total	45	Total		Total		Total	140	Total	140	Total		Total		Total	

Identify fitting by Group Number and Letter shown in Fig. 6.8 Manual D.

**RESIDENTIAL DUCT DESIGN AND SIZING
UNIT III**

**JOB SHEET #1 — DETERMINE STATIC PRESSURE
DROP ACROSS AN EVAPORATOR COIL**

A. Tools and equipment

1. Forced air system selected by instructor
2. Inclined manometer
3. Drill
4. Duct tape
5. Pencil and paper
6. Safety glasses

B. Procedure

1. Put on safety glasses.
2. Examine the area around the system to make sure you have a safe working environment.
3. Drill into the supply air duct at a point just before the A coil a hole large enough to insert one end of the inclined manometer hose. (Figure 1)

FIGURE 1

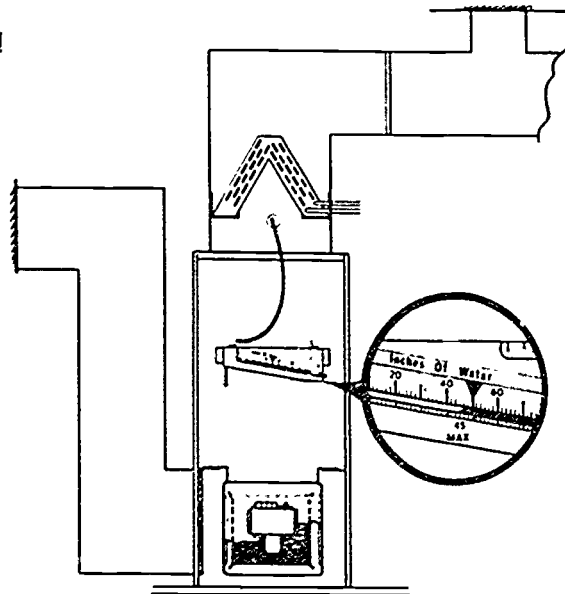

Courtesy Inter-City Products Corporation (USA)

4. Drill a second hole into the supply air duct at a point about 6 inches to the right (or left) of the top of the A coil. (Figure 2)

JOB SHEET #1

5. Open both ends of the manometer and attach the hoses.
6. Insert the hose from the high pressure side of the manometer into the hole before the A coil. (Figure 1)

FIGURE 2

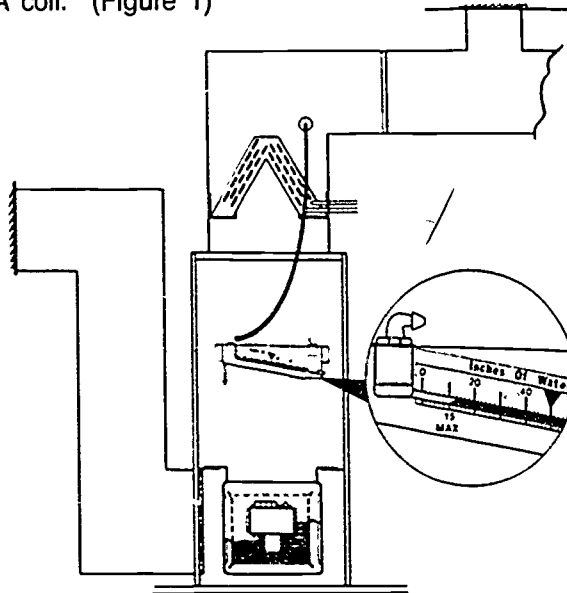

Courtesy Inter-City Products Corporation (USA)

7. Insert the hose from the low pressure side of the manometer into the hole to the upper right of the A coil. (Figure 2)
8. Read and record the static pressure drop across the coil:
_____.
9. Compare the reading with manufacturer's specifications for static pressure drop across the coil.
10. Check with your instructor if your reading is not in agreement with specifications because this indicates the system is not performing at peak efficiency.

(NOTE: An improper reading could mean something as simple as a coil that needs to be cleaned or a needed blower fan speed adjustment. It could also mean a system problem or a duct design problem. Discuss your finding with your instructor.)

- Have your instructor evaluate your work.
11. Remove manometer, tape holes with duct tape, and return equipment to proper storage.

**RESIDENTIAL DUCT DESIGN AND SIZING
UNIT III**

**JOB SHEET #2 — DETERMINE THE CFM BEING
DELIVERED BY A SELECTED FORCED AIR SYSTEM**

- A. Tools and equipment
1. Velometer or anemometer
 2. Forced air system as selected by instructor
 3. Safety glasses
- B. Procedure
1. Put on safety glasses
 2. Number the registers and grilles in order so you can keep track of all readings.

(NOTE: You may have to take more than one reading, so careful numbering will help you keep things straight.)
 3. Take a velocity reading at the face of all supply air registers with the velometer or anemometer.
 4. Record the readings: _____.
 5. Take a velocity reading at the face of the return air grille or grilles with the velometer or anemometer.
 6. Record the readings: _____.
 7. Compare the recorded readings to determine if the forced air system is producing the design air quantities in CFM.
 - Have you instructor evaluate your work.
 8. Discuss your findings with your instructor.
 9. Return velometer or anemometer to proper storage area.

**RESIDENTIAL DUCT DESIGN AND SIZING
UNIT III**

**PRACTICAL TEST #1
JOB SHEET #1 — DETERMINE THE PRESSURE DROP ACROSS
AN EVAPORATOR COIL**

Student's name _____ Date _____

Evaluator's name _____ Attempt no. _____

Student instructions: When you are ready to perform this task, ask you instructor to observe the procedure and complete this form. All items listed under "Process Evaluation" must receive a "yes" for you to receive an overall performance evaluation.

PROCESS EVALUATION

(EVALUATOR NOTE: Place a check mark in the "Yes" or "No" blanks to designate whether or not the student has satisfactorily achieved each step in this procedure. If the student is unable to achieve this competency, have the student review the materials and try again.)

The student:	YES	NO
1. Wore safety glasses.	<input type="checkbox"/>	<input type="checkbox"/>
2. Drilled holes in supply/return ducts.	<input type="checkbox"/>	<input type="checkbox"/>
3. Used manometer properly.	<input type="checkbox"/>	<input type="checkbox"/>
4. Recorded static pressure before coil.	<input type="checkbox"/>	<input type="checkbox"/>
5. Recorded static pressure after coil.	<input type="checkbox"/>	<input type="checkbox"/>
6. Determined total pressure drop across evaporator coil.	<input type="checkbox"/>	<input type="checkbox"/>
7. Patched holes in ducts and secured equipment.	<input type="checkbox"/>	<input type="checkbox"/>

Evaluator's comments: _____

JOB SHEET #1 PRACTICAL TEST

PRODUCT EVALUATION

(EVALUATOR NOTE: Rate the student on the following criteria by circling the appropriate numbers. Each item must be rated at least a "3" for mastery to be demonstrated. (See performance evaluation key below.) If the student is unable to demonstrate mastery, student materials should be reviewed and another test procedure must be submitted for evaluation.)

 Criteria:

 Equipment
Use

	4	3	2	1
--	---	---	---	---

 Site
Preparation

	4	3	2	1
--	---	---	---	---

 Static Pressure
Measurements

	4	3	2	1
--	---	---	---	---

 Safe Working
Practices

	4	3	2	1
--	---	---	---	---

 EVALUATOR'S COMMENTS: _____

PERFORMANCE EVALUATION KEY
<p>4 — Skilled — Can perform job with no additional training.</p> <p>3 — Moderately skilled — Has performed job during training program; limited additional training may be required.</p> <p>2 — Limited skill — Has performed job during training program; additional training is required to develop skill.</p> <p>1 — Unskilled — Is familiar with process, but is unable to perform i b.</p>

(EVALUATOR NOTE: If an average score is needed to coincide with a competency profile, total the designated points in "Product Evaluation" and divide by the total number of criteria.)

**RESIDENTIAL DUCT DESIGN AND SIZING
UNIT III**

**PRACTICAL TEST #2
JOB SHEET #2 — DETERMINE THE CFM BEING DELIVERED
BY A SELECTED FORCE AIR SYSTEM**

Student's name _____ Date _____

Evaluator's name _____ Attempt no. _____

Student instructions: When you are ready to perform this task, ask you instructor to observe the procedure and complete this form. All items listed under "Process Evaluation" must receive a "yes" for you to receive an overall performance evaluation.

PROCESS EVALUATION

(EVALUATOR NOTE: Place a check mark in the "Yes" or "No" blanks to designate whether or not the student has satisfactorily achieved each step in this procedure. If the student is unable to achieve this competency, have the student review the materials and try again.)

The student:	YES	NO
1. Took velocity readings at supply air registers.	<input type="checkbox"/>	<input type="checkbox"/>
2. Took velocity readings are return air grilles.	<input type="checkbox"/>	<input type="checkbox"/>
3. Compared readings to determine CFM being delivered by system.	<input type="checkbox"/>	<input type="checkbox"/>
4. Secured equipment.	<input type="checkbox"/>	<input type="checkbox"/>
5. Worked safely.	<input type="checkbox"/>	<input type="checkbox"/>

Evaluator's comments: _____

JOB SHEET #2 PRACTICAL TEST

PRODUCT EVALUATION

(EVALUATOR NOTE: Rate the student on the following criteria by circling the appropriate numbers. Each item must be rated at least a "3" for mastery to be demonstrated. (See performance evaluation key below.) If the student is unable to demonstrate mastery, student materials should be reviewed and another test procedure must be submitted for evaluation.)

Criteria:

Supply air velocity measurement	4	3	2	1
Return air velocity measurement	4	3	2	1
CFM Calculations	4	3	2	1
Safe Working Practices	4	3	2	1

EVALUATOR'S COMMENTS: _____

PERFORMANCE EVALUATION KEY

- 4 — **Skilled** — Can perform job with no additional training.
- 3 — **Moderately skilled** — Has performed job during training program; limited additional training may be required.
- 2 — **Limited skill** — Has performed job during training program; additional training is required to develop skill.
- 1 — **Unskilled** — Is familiar with process, but is unable to perform job.

(EVALUATOR NOTE: If an average score is needed to coincide with a competency profile, total the designated points in "Product Evaluation" and divide by the total number of criteria.)

**RESIDENTIAL DUCT DESIGN AND SIZING
UNIT III**

TEST

Name _____ Score _____

1. Match the terms on the right with the correct definitions.

(NOTE: Terms on this page apply only to definitions on this page.)

- | | | | |
|-------|---|-----|---------------------|
| _____ | a. Commercially designed "Total" air conditioning systems including mechanical equipment, ducts, fittings, registers and grilles | 1. | Effective length |
| _____ | b. The force per unit area, perpendicular to the direction of flow in a duct | 2. | Plenum |
| _____ | c. A box-like fitting that the air handler either discharges air into or receives air from | 3. | Trunk |
| _____ | d. Tube or channel used to convey air | 4. | Take-off |
| _____ | e. A duct fitting that adapts the duct to a wall stack, a register or grille | 5. | Proprietary systems |
| _____ | f. The point of departure from a duct to which a duct fitting is attached to accomplish branching of ductwork | 6. | Actual length |
| _____ | g. A method of expressing the friction loss of duct fittings by comparing the fitting loss to the loss in a straight duct | 7. | Duct |
| _____ | h. The length of a duct expressed in feet and inches | 8. | Static pressure |
| _____ | i. Expressed in feet is the sum of actual and equivalent length | 9. | Boot |
| _____ | j. A section of duct that services one outlet, sometimes called a runout | 10. | Branch |
| _____ | k. A section of duct that handles more than one outlet | 11. | Diffuser |
| _____ | l. A supply air outlet composed of deflecting elements discharging air in various directions and patterns to accomplish mixing of supply and room air | 12. | Equivalent length |

TEST

(NOTE: Terms on this page apply only to definitions on this page.)

- | | | | |
|----------|---|-----|-------------------------|
| _____m. | Sizes the duct system so that the friction loss for the supply duct runs are approximately equal and the friction loss for all the return runs are approximately the same | 13. | Floor warming |
| _____n. | The sum of the negative and positive static pressure being exerted by a blower | 14. | System pressure |
| _____o. | Air currents set in motion by cooling and warming of air brought in contact with hot or cold surfaces such as walls or windows | 15. | Sensible heat ratio |
| _____p. | Condition in which there is little or no air movement in a room; air lies in temperature layers | 16. | Ceiling or wall effect |
| _____q. | Temperature change from one level or stratum to the next as in the change from floor to ceiling | 17. | Equal friction method |
| _____r. | The transfer of large masses of air due to convection currents in a structure often caused by warm air rising and cooler air falling through building accesses such as stairs | 18. | Pressure drop |
| _____s. | A thin, rectangular duct which runs vertically inside a wall | 19. | Stratification of air |
| _____t. | A peculiar ability of moving air to cling to a ceiling or a wall | 20. | IWG |
| _____u. | Feet per minute, a measurement of velocity | 21. | Convection currents |
| _____v. | Floor heating by burying ducts in concrete slab floors or by running supply ducts under floors | 22. | Cooling air flow factor |
| _____w. | The phenomenon of static pressure diminishing from maximum at the blower to zero after passing through an outlet regardless of duct length | 23. | Heating air flow factor |
| _____x. | Inches of water gauge | 24. | Wall stack |
| _____y. | Amount of airflow rate required to deliver 1.0 BTUH of heat to any outlet in the structure | 25. | Cascade effect |
| _____z. | Amount of airflow rate required to deliver 1.0 BTUH of sensible cooling to any outlet in the structure | 26. | Temperature gradient |
| _____aa. | Ratio of calculated sensible load to the calculated total load | 27. | FPM |

TEST

2. Identify types of supply duct systems. Write the proper system name below the appropriate illustration.

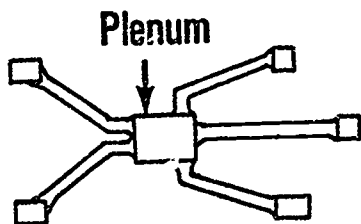

a. _____

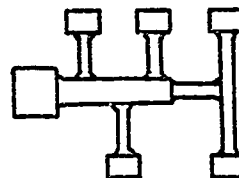

b. _____

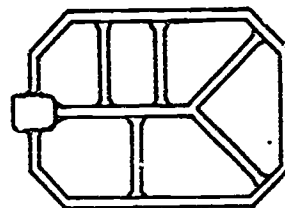

c. _____

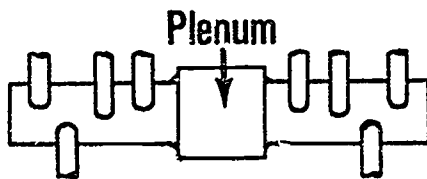

d. _____

TEST

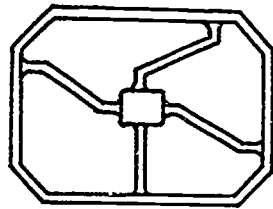

e. _____

3. Solve problems concerning factors affecting system design and the effects they have on the system. Select the best solution to each problem.
- a. You want to know how the addition of an extra duct branch is going to affect system heating. In general, you can quickly evaluate because:
- 1) Greater duct length will double the heating load.
 - 2) Greater duct length reduces the temperature of warm air passing through the duct.
 - 3) The increase in length will probably be insignificant.
- b. To assure maximum efficiency in a system, even after all equipment is properly sized, what could you do?
- 1) Increase blower speed.
 - 2) Decrease blower speed.
 - 3) Insulate all ducts with the duct wrap.
- c. You are working with a co-worker who claims that all supply outlets should be the same. You disagree because you know:
- 1) Supply outlets should be the same only for upstairs rooms.
 - 2) Supply outlets will vary with design features because size and location greatly affect the efficiency of a system.
 - 3) Supply outlets are determined strictly by the size of the duct.
4. Match major steps in air system design with their procedures.
- | | |
|--|--|
| <p>_____ a.</p> <ol style="list-style-type: none"> 1) Calculate total system load. 2) Calculate heating and cooling CFM. 3) Determine appropriate type of equipment to be used. 4) Select proper sized unit for heating. | <ol style="list-style-type: none"> 1. Select registers and grilles for supply and return air. 2. Lay out and size duct work. 3. Select heating and cooling equipment. 4. Select air distribution system. |
|--|--|

TEST

- 5) Select condensing unit and evaporator coil for cooling.
 - 6) Determine location of condensing unit, heating equipment, and thermostat.
- _____ b.
- 1) Examine floor plan to determine appropriate outlet register.
 - 2) Select appropriate registers based on correct distribution patterns.
 - 3) Select the proper return air grille size.
- _____ c.
- 1) Determine climatic region.
 - 2) Determine design of structure.
 - 3) Determine location of ducts.
 - 4) Determine best type of distribution system.
- _____ d.
- 1) Determine appropriate location of duct work.
 - 2) Calculate number of outlet and inlet openings.
 - 3) Calculate the CFM required for each outlet.
 - 4) Determine the type of duct to be used and draw the runs.
 - 5) Obtain the equivalent lengths of fittings.
 - 6) Determine the total effective length of ducts.
 - 7) Determine the external static pressure drop per 100 ft.
 - 8) Size duct using appropriate charts.

TEST

5. Select factors affecting return air duct design. Place an "X" beside each true statement.

- ___ a. Return air inlets are normally placed within 60 feet of a supply.
- ___ b. Return air inlets should be placed on every level of a split level residence.
- ___ c. Return air inlets are not normally placed in a kitchen or a bathroom.
- ___ d. Return air inlets are normally placed so that air from one room is not moved through another room before entering the return air inlet.
- ___ e. Return air duct systems must be designed for a design air volume equal to or greater than the supply air volume.
- ___ f. Return air duct systems must be designed for a design air volume equal to or less than the supply air volume.
- ___ g. Place a return air inlet on only the upper level of a split level residence.
- ___ h. An optimum system has a return air inlet in each bedroom.
- ___ i. Return air inlets are usually placed on inside walls which allows shorter duct work.
- ___ j. Doors over add-on carpet require no special attention.

6. List four locations of registers and grilles.

- a. _____
- b. _____
- c. _____
- d. _____

7. Solve problems concerning advantages and disadvantages for locations of registers and grilles. Select the best solution to each problem.

- a. In a colder climate where keeping warm is the focus of system design, your boss has recommended a perimeter duct system, and the customer wants to know why. You should say something to the effect that:
 - 1) Perimeter systems are customary in cold climates.
 - 2) Perimeter systems are easier to service.
 - 3) Perimeter systems deliver the highest level of heating comfort because they deliver conditioned air at the greatest points of heat loss and heat gain.

TEST

- b. A customer wants to know why an engineer called for a high inside wall system in a residential design. Considering the climate is warm enough that cooling is more of a concern than heating, you answer:
- 1) High inside wall systems are well suited for areas where heating is of less importance than cooling.
 - 2) High inside wall systems are easier to install.
 - 3) High inside wall systems can be easily extended after initial installation.
- c. A potential customer is changing over a central forced air HVAC system from a hydronic system. The customer would like to have ceiling registers so the system wouldn't interfere with furniture placement. However, the cold climate means that the customer could experience:
- 1) An added cost for ceiling registers.
 - 2) Not enough air movement for proper cooling in summer.
 - 3) Cold floors in the winter.
8. Complete statements concerning climatic zone conditions. Circle the material that best completes each statement.
- a. Zone A
- 1) Cold weather is more severe and (more prolonged) (unpredictable).
 - 2) Summers are (relatively mild) (extremely mild).
- b. Zone B
- 1) (Less) (Equally) severe winters as Zone A.
 - 2) (Cooler) (hotter) days for extended periods.
- c. Zone C
- 1) Has (mild) (cool) winters
 - 2) Has (hot) (humid) summers
9. Match air control devices with their applications.
- | | | | |
|---------|--|----|----------|
| _____a. | Device used to vary the airflow rate through a duct, diffuser or register | 1. | Vane |
| _____b. | A fixed or adjustable device used to direct air flow | 2. | Register |
| _____c. | A louvered or perforated covering of an inlet outlet opening through which air flows | 3. | Damper |
| _____d. | A combination grille and damper device covering an air inlet or outlet opening | 4. | Grille |

TEST

10. Complete statements concerning factors to consider in distribution of conditioned air. Circle the material that best completes each statement.

- a. (Quality) (velocity) of primary air
- b. Desired temperature of (ventilating air) (room air)
- c. Proper sizing and location of grilles and registers to minimize (cost) (discomfort from noise and drafts)
- d. (Quantity) (velocity) of air in duct system

11. Match grille design factors with their meanings.

- | | | |
|----------|--|----------------------|
| _____ a. | An arbitrary maximum velocity of an air stream which spreads or drops into a living area, usually considered comfortable at 50 fpm | 1. Primary air |
| _____ b. | The distance an airstream travels after leaving a supply outlet before the velocity is reduced to the terminal velocity | 2. Drop |
| _____ c. | The distance air falls vertically below a high sidewall supply outlet before slowing to terminal velocity | 3. Floor warming |
| _____ d. | The maximum width of the total airstream at the point of terminal velocity | 4. Terminal velocity |
| _____ e. | A mixture of supply air from an outlet and room air at velocities about 150 fpm | 5. Entrained air |
| _____ f. | Room air which is dragged into the primary air and raised to higher velocities inside the primary air envelope | 6. Throw |
| _____ g. | Floor heating by burying ducts in concrete slab floors or by running supply ducts under floors | 7. Spread |

12. Match outlet placement with recommended velocities.

- | | | |
|----------|-------------|----------------------------|
| _____ a. | 450 fpm | 1. Baseboard diffusers |
| _____ b. | 700 fpm | 2. High sidewall registers |
| _____ c. | 350-500 fpm | 3. Floor diffusers |
| _____ d. | 500 fpm | 4. Low sidewall registers |

TEST

13. Select true statements concerning air duct calculators. Place an "X" beside each true statement.
- ___ a. Hand-held air duct calculators are handy for sizing duct and for checking calculations.
 - ___ b. Air duct calculators can be used to size duct with the equal-friction method only.
 - ___ c. Air duct calculators are frequently stocked by dealers and distributors and may be available locally.
 - ___ d. The flip side of some calculators presents company advertising and little more.

(NOTE: If the following activities have not been accomplished prior to the test, ask your instructor when they should be completed.)

- 14. Solve problems using the friction chart for sheet metal duct. (Assignment Sheet #1)
- 15. Solve problems using the friction chart for flex duct. (Assignment Sheet #2)
- 16. Design an air distribution system from a drawing. (Assignment Sheet #3)
- 17. Demonstrate the ability to:
 - a. Determine the pressure drop across an evaporator coil. (Job Sheet #1)
 - b. Determine the CFM being delivered by a given forced air system. (Job Sheet #2)

**DUCT DESIGN AND SIZING
UNIT III**

ANSWERS TO TEST

- | | | | | | |
|----|--|---|--|--|--------------------------|
| 1. | a. 5
b. 8
c. 2
d. 7
e. 9
f. 4 | g. 12
h. 6
i. 1
j. 10
k. 3
l. 11 | m. 17
n. 14
o. 21
p. 19
q. 26
r. 25 | s. 24
t. 16
u. 27
v. 13
w. 18
x. 20 | y. 23
z. 22
aa. 15 |
|----|--|---|--|--|--------------------------|
2. a. Radial or spider
b. Trunk and branch reducing plenum
c. Perimeter loop trunk duct
d. Trunk and branch extended plenum
e. Perimeter loop radial duct
3. a. 2)
b. 3)
c. 2)
4. a. 3
b. 1
c. 4
d. 2
5. b, c, d, e, h, i
6. a. Perimeter
b. High inside wall
c. Low inside wall
d. Ceiling
7. a. 3)
b. 1)
c. 3)
8. a. 1) More prolonged
2) Relatively mild
b. 1) Less
2) Hotter
c. 1) Mild
2) Hot

ANSWERS TO TEST

9. a. 3
b. 1
c. 4
d. 2
9. a. 3
b. 1
c. 4
d. 2
10. a. Velocity
b. Room air
c. Discomfort from noise and drafts
d. Velocity
11. a. 4 e. 1
b. 6 f. 5
c. 2 g. 3
d. 7
12. a. 3
b. 1
c. 2
d. 4
13. a, c
14. Evaluated to the satisfaction of the instructor
15. Evaluated to the satisfaction of the instructor
16. Evaluated to the satisfaction of the instructor
17. a. Evaluated according to criteria in Practical Test #1
b. Evaluated according to criteria in Practical Test #2

**RESIDENTIAL AIR TREATMENT
UNIT IV****UNIT OBJECTIVE**

After completion of this unit, the student should be able to plan air contaminant control and also be able to install devices used in residential air treatment. These competencies will be demonstrated by completing the job sheets and by scoring a minimum of 85 percent on the unit test.

SPECIFIC OBJECTIVES

After completion of this unit, the student should be able to:

1. Match terms related to residential air treatment with their correct definitions.
2. Complete statements concerning air contaminants that affect humans.
3. Solve problems concerning the advantages of maintaining proper humidity in a residence.
4. Select from a list those factors which affect humidity in a residence.
5. Complete a chart showing features of common types of residential filtering equipment.
6. Select true statements concerning the operation of an electronic air cleaner.
7. Select true statements concerning operation of a dehumidifier.
8. Select true statements concerning the operation of a typical humidifier with a forced air furnace.
9. Solve problems concerning air-to-air exchangers.
10. Complete statements concerning radon monitoring.
11. Demonstrate ability to:
 - a. Install a humidifier with low voltage controls. (Job Sheet #1)
 - b. Install an electronic air cleaner. (Job Sheet #2)

RESIDENTIAL AIR TREATMENT UNIT IV

SUGGESTED ACTIVITIES

- A. Obtain additional materials and/or invite resource people to class to supplement/reinforce information provided in this unit of instruction.

(NOTE: This activity should be completed prior to the teaching of this unit.)

- B. Make transparencies from the transparency masters included with this unit.
- C. Provide students with objective sheet.
- D. Discuss unit and specific objectives.
- E. Provide students with information sheets.
- F. Discuss information sheets.

(NOTE: Use the transparencies as needed to enhance the information.)

- G. Provide students with job sheets.
- H. Discuss and demonstrate the procedures outlined in the job sheets.
- I. Integrate the following activities throughout the teaching of this unit:
1. Show an electronic air cleaner and components.
 2. Show a humidifier and components.
 3. Show an air exchanger unit (if not readily available, see if you can acquire brochures from a local supplier, to hand out to the students).
 4. Meet individually with students to evaluate their progress through this unit of instruction, and indicate to them possible areas for improvement.
- J. Give test.
- K. Evaluate test.
- L. Reteach if necessary.

REFERENCES USED IN WRITING THIS UNIT

- A. Althouse, Andrew D., and Carl H. Turnquist and Alfred F. Bracciano. *Modern Refrigeration and Air Conditioning*. South Holland, IL 60473: The Goodheart-Willcox Company, Inc., 1988.

SUGGESTED ACTIVITIES

- B. *Heat Recovery Ventilators Radon Applications*. Rockland, MA 02370: AIRXCHANGE, Inc., 1988.
- C. Eckes, William, and Dan Fulkerson. *Air Conditioning and Refrigeration, Book III*. Stillwater, OK 74074: Mid-America Vocational Curriculum Consortium, 1981.
- D. Whitman, William C. and William M. Johnson. *Refrigeration and Air Conditioning Technology*. Albany, NY 12212: Delmar Publishers Inc., 1987.
- E. *AIRXCHANGE Fresh-Air Recovery Systems* (Product Brochure). Rockland, MA 02370: AIRXCHANGE, Inc., 1988.

AVAILABLE TRAINING MATERIALS

- A. Because radon poses health hazards to limited areas of North America, the subject is treated at a really fundamental level in this unit. However, for areas where radon does pose a problem, the following free materials will prove of value for instructors and students alike:
1. *A Citizens Guide to Radon*.
 2. *Radon Reduction Methods, A Homeowner's Guide (Second Edition)*
 3. *Removal of Radon from Household Water*
 4. *Radon Reduction in New Construction, An Interim Guide*
 5. *Application Package for The Radon Contractor Proficiency Program*.
 - All items are available from: United States Environmental Protection Agency
 - Contact your regional EPA office or your state radiation detection office.
- B. Heat recovery ventilation (HRV) as outlined by the EPA for radon control has been developed and tested by AIRXCHANGE of Rockland, Massachusetts. Using a balanced heat recovery system, AIRXCHANGE systems have achieved a more than 90% radon reduction. For information on testing or the systems, call (617)871-3029 or write:

AIRXCHANGE
401 V.F.W. Drive
Rockland, MA 02370

**RESIDENTIAL AIR TREATMENT
UNIT IV****INFORMATION SHEET****I. Terms and definitions**

- A. **Micron** — A unit of linear measurement which is one thousandth of a millimeter

(NOTE: Anything smaller than 10 microns is invisible to the naked eye.)
- B. **Humidistat** — A control for regulating humidity in conditioned air
- C. **Immersion heater** — An electric heating element in a water container
- D. **Impingement type filter** — A filter which contains matted or porous material for removing foreign particles from conditioned air
- E. **Particulates** — Minute particles of various solid substances in the air
- F. **Aeroallergens** — Airborne substances which cause allergies in humans
- G. **RH** — Relative humidity; the measurement of moisture in the air
- H. **Ionization** — Process of breaking a substance into positive and negative particles or charges
- I. **Air-to-Air Exchanger** — Device for exhausting stale air by bringing in fresh air and recovering some of the heating or cooling that normally would be lost in the process
- J. **Chemical control** — The addition of chemicals to control bacteria in humidifiers that have a standing water supply
- K. **Descaling** — The reduction of mineral deposit build-up with use of special filters or chemicals in certain types of humidifiers
- L. **Electrostatic** — A filtering device that uses media with a charged surface to attract and collect particulate matter
- M. **Radon** — A gas that causes lung cancer; it occurs naturally as the radioactive decay of radium and is found in uranium-holding soil areas of the U.S. and Canada

INFORMATION SHEET**II. Air contaminants that affect humans****A. Size**

1. Larger than 2 microns will be expelled by the lungs.
2. Smaller than 2 microns will be retained in the lungs.

(NOTE: Particles of .1 to 1 micron will usually remain in the air; 99% of all particles in the air are smaller than 1 micron.)

B. Type

1. Particulates
2. Aeroallergens
3. A "tight" energy saving home may have an indoor air pollution problem, such as radon gases and other pollutants given off by building materials.

III. Advantages of maintaining proper humidity in a residence (Transparency 1)

- A. Promotes health by maintaining moisture needed by mucus membranes in nasal passages
- B. Reduces static electricity in floor coverings
- C. Prolongs life of wooden furniture by preventing drying of glued joints
- D. Prolongs life of textiles
- E. Reduces house dust
- F. Prolongs life of window sills, doors, and other construction materials

(NOTE: Too much humidity can cause rotting, mold, or mildew.)

- G. Promotes human comfort

IV. Factors affecting humidity in a residence

- A. Outside air temperature
- B. Appliance use and food preparation
- C. Number of occupants and activities
- D. Plumbing and water usage
- E. Type of construction
- F. Quality of components

INFORMATION SHEET

V. Features of common types of residential filtering equipment

Type	Permanent Filter	Throw-away Filter	Electronic	Electrostatic
Initial cost	average	low	high	average
Filter source	adhesive coating	adhesive screen-like fibers	opposing charged elements and primary fiber filter	opposing electrostatically charged elements with air passing over media
Service or maintenance	average: clean and coat plate	simple: replace filter	average: wash elements	average: wash media
Operating cost	average	low	high	low
Effectiveness	good	average	excellent	good

VI. Operation of an electronic air filter (Transparency 2)

- A. Return air first passes through a pre-filter to remove larger particles.
- B. Partially filtered air enters an ionized field.
- C. A wire grid with high positive voltage charges the particles in the air.
- D. Negatively charged plates attract the particles that have been positively charged.
- E. The particles are held on the collector plates until the unit is de-energized and cleaned.
- F. Filtered air is ready to be conditioned by heating or cooling system.

(NOTE: For typical installation arrangements see Transparency 3)

VII. Operation of a dehumidifier (Transparency 4)

(NOTE: A dehumidifier is a small hermetic refrigerating system with an evaporator and condenser both enclosed in a cabinet.)

- A. Room or conditioned air is drawn into the unit by a blower.
- B. Air is cooled as it passes over the evaporator coil.
- C. Water vapor in the air condenses as it is cooled below its dew point.
- D. Condensation collects on the evaporator and drips into a collector tray and is removed.
- E. The cooled air is passed over the condenser coil to reheat it to a comfortable level.

INFORMATION SHEET

- F. Treated air is blown into the room or ductwork.

(NOTE: Some dehumidifiers use a chemical to remove water. Moisture is absorbed by the chemical and the chemical is heated to remove the moisture in another part of the unit. Moisture is then exhausted to outside air and the chemical is reused.)

VIII. Operation of a typical humidifier with a forced air furnace

- A. The humidifier is installed on the return air plenum or duct and connected to the supply air plenum with flexible pipe. (Figure 1)
- B. The by-passed supply (warm) air flows over a moist foam filter which rotates in a water reservoir.
- C. The moistened warm air reenters the air stream on the return air side of the furnace.
- D. A humidifier with a separate fan is controlled by a humidistat.

(NOTE: Some humidifiers spray a fine mist of water into the system, some work with pans or drums, but all types are designed to increase the RH of supply air when heating makes household air too dry.)

FIGURE 1

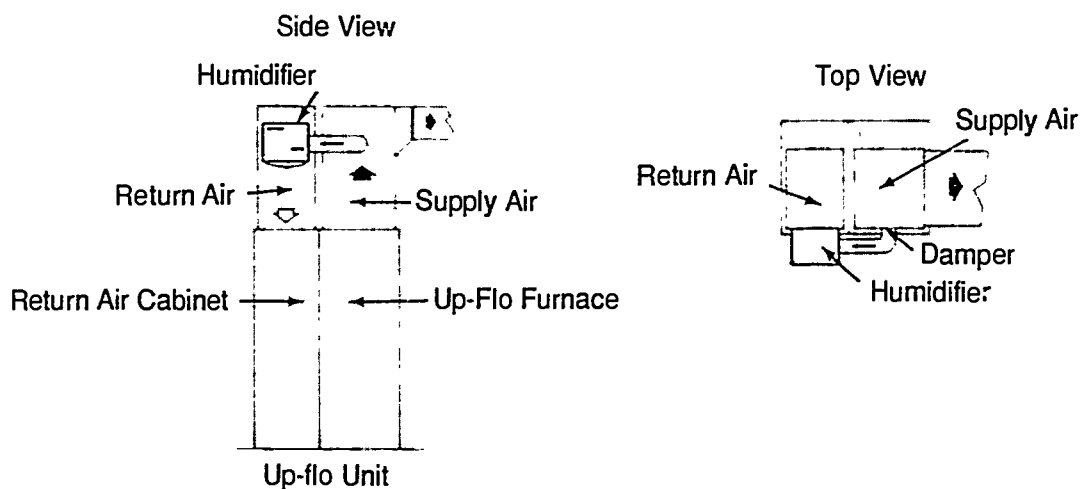

Courtesy Lennox Industries, Inc.

INFORMATION SHEET

IX. Air-to-air exchanger

- A. In a quest to save energy, modern homes are often so well insulated or built so tight that ventilation can be cut up to 90%.
- B. Lower infiltration and ventilation saves money, but it also results in indoor contamination where unhealthy (even dangerous) contaminants are recycled through living spaces.
- C. To solve the problem of indoor contamination, more and more local codes require forced ventilation which brings in fresh air and exhausts stale air.
- D. Pre-heating cold air in the winter or pre-cooling hot air in the summer could increase energy costs, but air-to-air exchangers avoid this by using already warm or already cool inside air to pre-heat or pre-cool outside air.
- E. One air-to-air exchanger manufacturer uses an energy recovery wheel with a moisture-balancing action that often eliminates the need for the added cost of a humidifier or dehumidifier. (Figure 2)

FIGURE 2

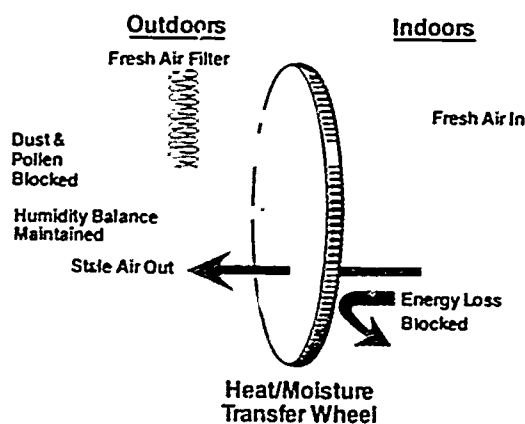

Courtesy AIRXCHANGE, Inc.

INFORMATION SHEET

- F. In summer, warm humid outside air passes energy recovery wheel where it is cooled by the stale inside air being exhausted. (Figure 3)

FIGURE 3

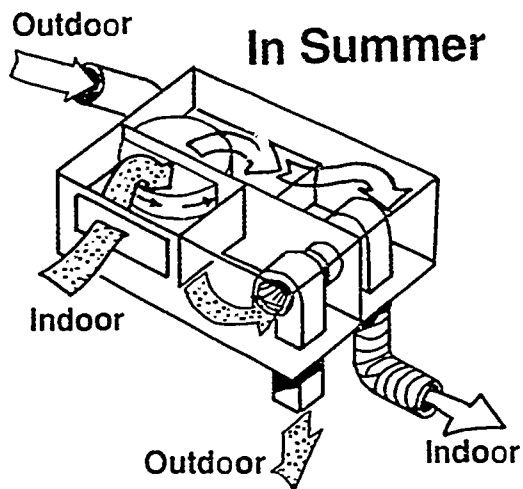

Courtesy AIRXCHANGE, Inc.

- G. In winter, dry cold outside air passes through the wheel where it is warmed by heat extracted from the stale air being exhausted. (Figure 4)

FIGURE 4

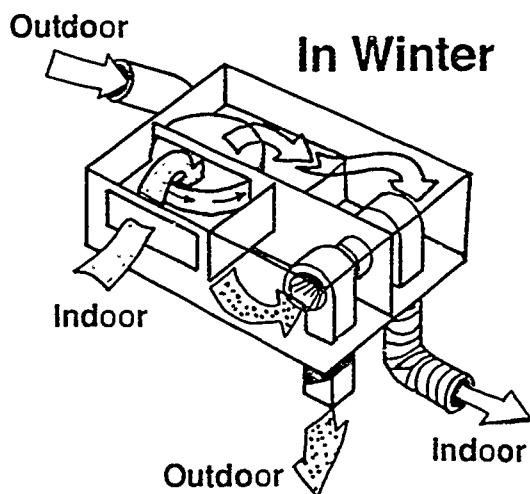

Courtesy AIRXCHANGE, Inc.

- H. In winter, excess moisture is also exhausted to help avoid damaging condensation on windows and walls.
- I. In summer, a replaceable filter helps keep out dust and pollen.

(NOTE: Some air-to-air exchangers have special applications for the control of radon pollution.)

INFORMATION SHEET

X. Radon monitoring (Transparency 5)

- A. Radon is a radioactive gas that comes from a natural breakdown of radium and is found in high concentrations in soils and rocks containing uranium.
- B. Radon enters homes through cracks in walls and floors, sometimes in the water supply, through porous concrete, and especially through basements with cracked walls or floors.
- C. In areas with high-risk radon potential, a preliminary radon check should be made prior to the installation of HVAC equipment.
- D. To check for the presence of radon, use a charcoal canister or an alpha track detector; they are both inexpensive and readily available at local hardware and other stores. (Figure 5)

FIGURE 5

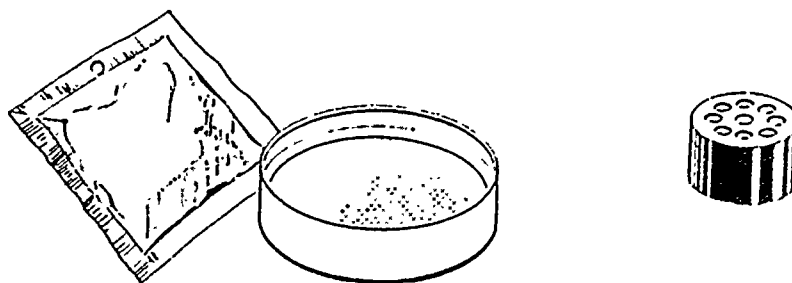

Charcoal Canister

Alpha Track Detector

Courtesy The Environmental Protection Agency

- E. If a canister or alpha track detector indicates a presence of radon, the homeowner should contact a regional office of the Environmental Protection Agency (EPA) or the state radiation protection service.

Types of Humidifiers

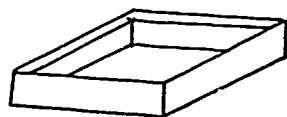

Open Pan

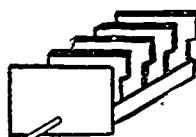

Water Supply

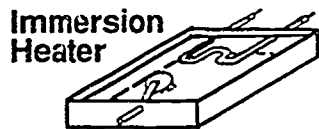

Immersion Heater

Float Valve

Pan Type Humidifiers



Stationary Plates

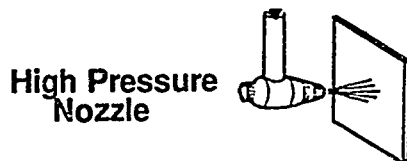

High Pressure Nozzle

Splash Plate Or Pad

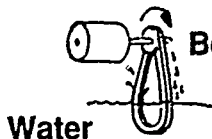

Belt or 'O' Ring

Water

Atomizing Humidifiers

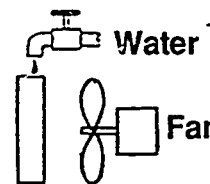

Pad or Element

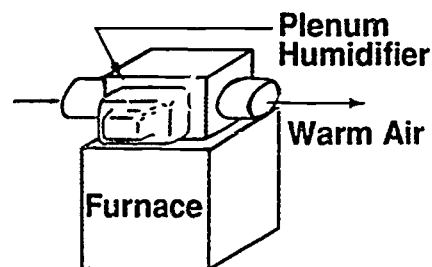

Plenum Humidifier

Furnace

Warm Air

By-Pass Humidifier

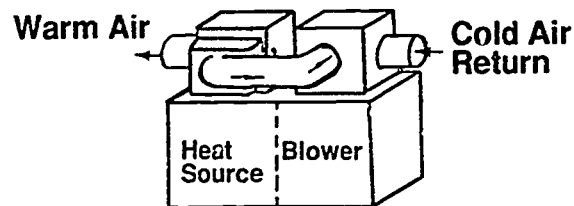

Heat Source

Blower

Warm Air

Cold Air Return

Wetted Element Humidifiers

Ionizing Air Filter

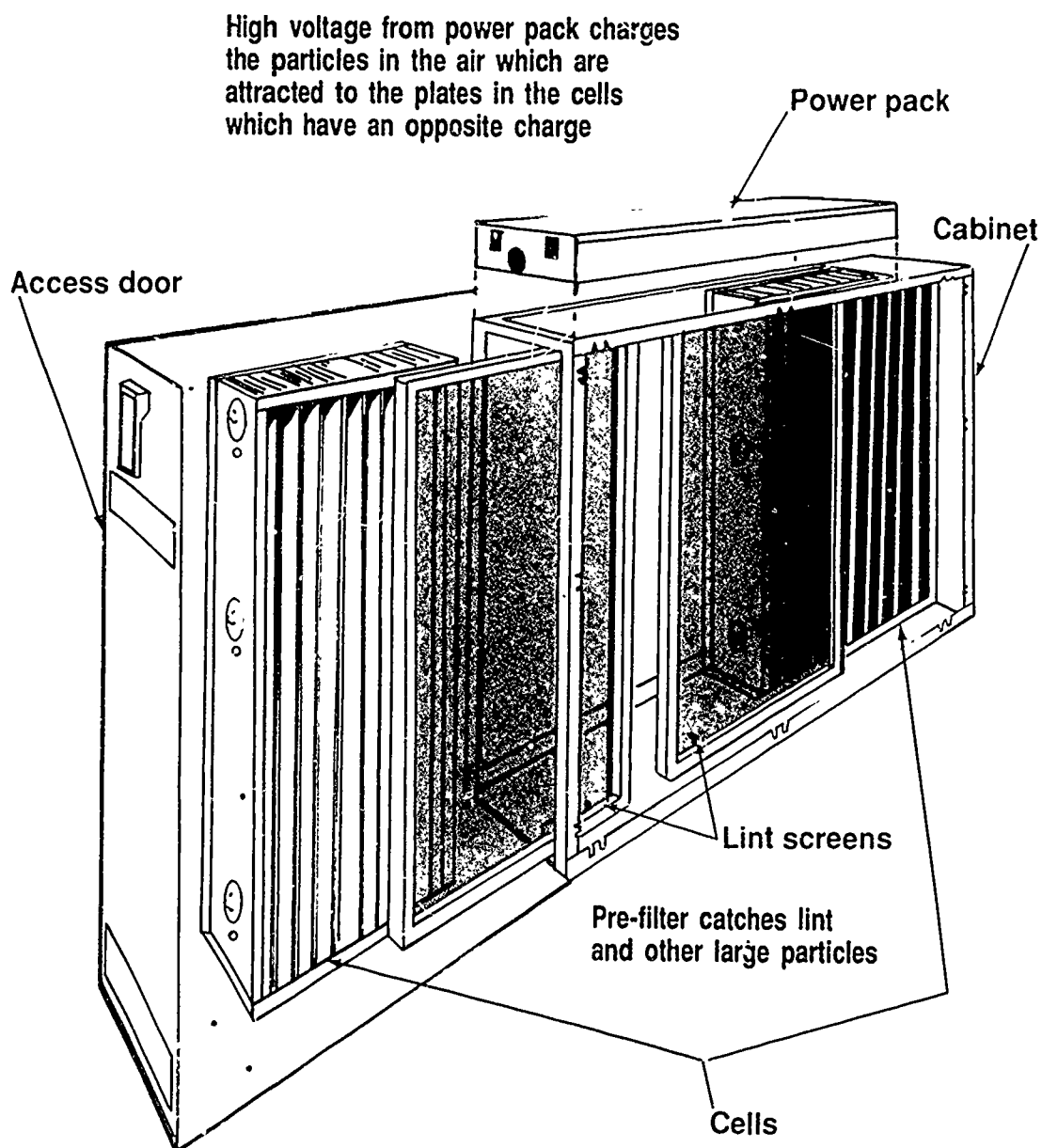

Courtesy Trion, Inc.

Installation and Wiring: Electronic Air Filter

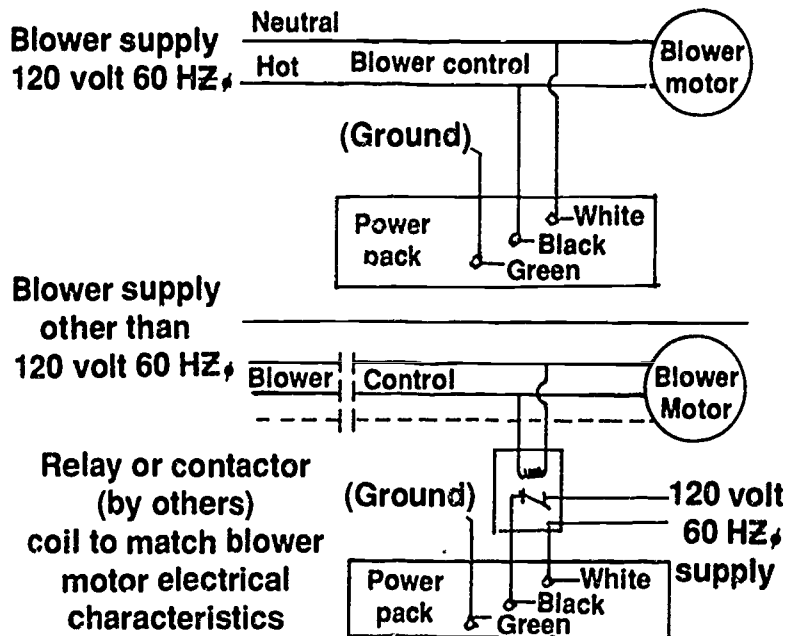
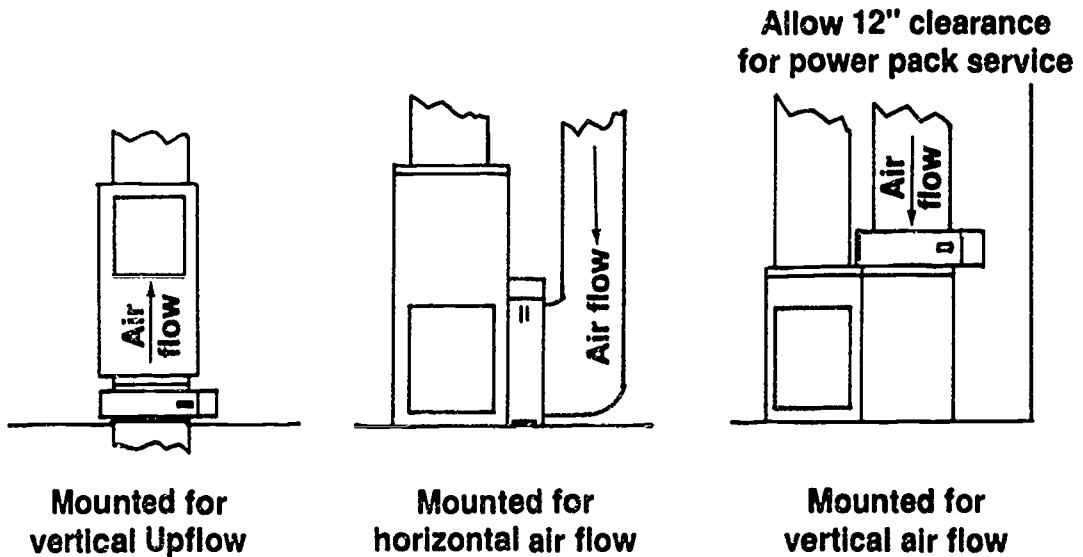

Courtesy Trion, Inc.

Components of a Dehumidifier

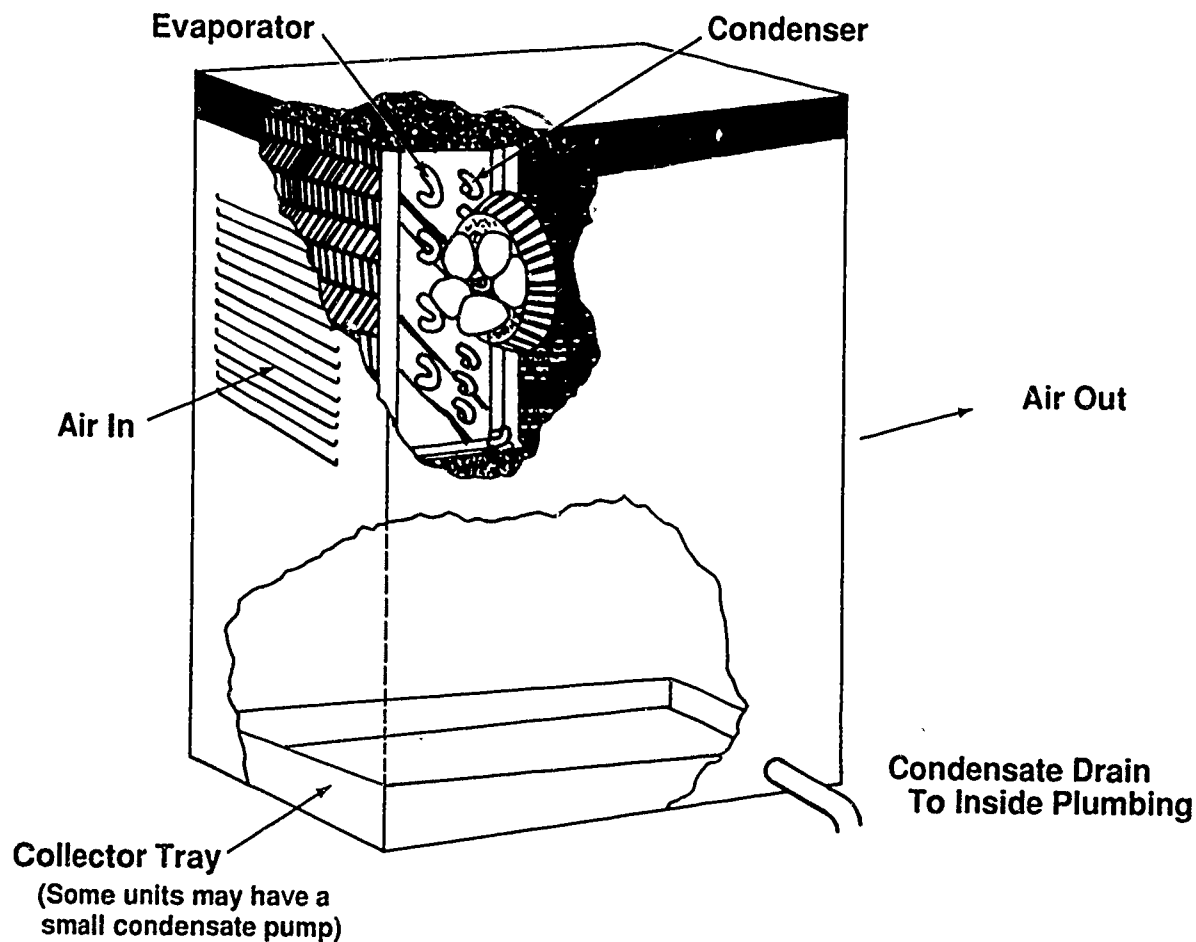

Common Radon Entry Points

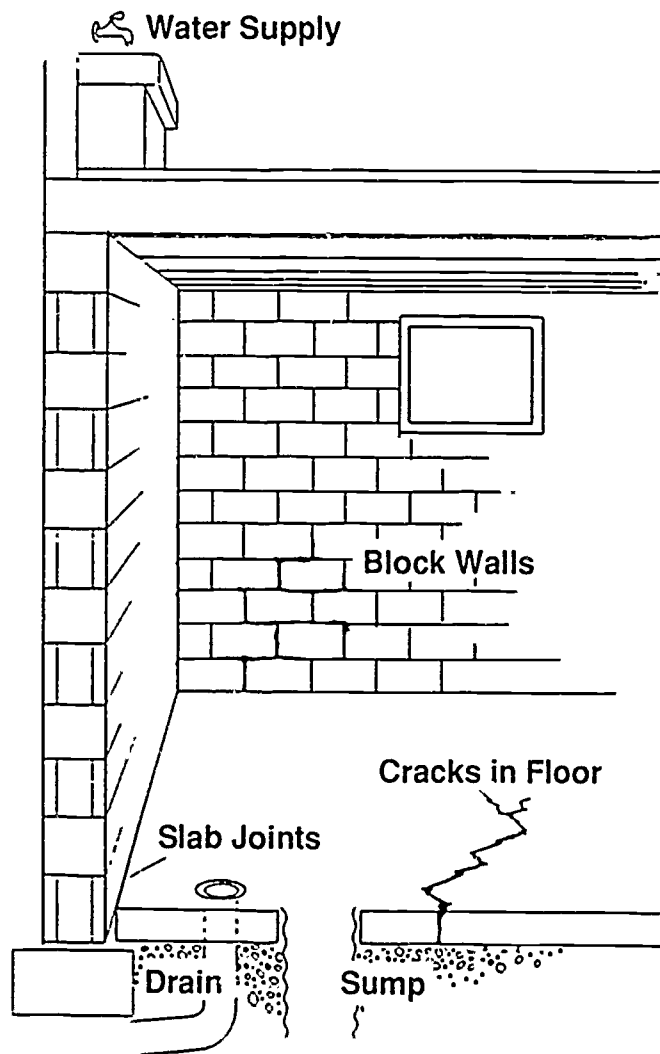

Courtesy Environmental Protection Agency

RESIDENTIAL AIR TREATMENT
UNIT IV

JOB SHEET #1 — INSTALL A HUMIDIFIER WITH
LOW VOLTAGE CONTROLS

A. Tools and equipment

1. Humidifier and accessories
2. Screwdriver
3. Aviation snips
4. 1/4" OD copper tubing as needed
5. Thermostat cable (2-wire #18) as needed
6. SPST relay (24v coil)
7. #14 insulated stranded wire as needed or to local codes
8. Sheet metal screws as required
9. Other materials specified by manufacturer's instructions
10. Forced air heating system as selected by instructor
11. Safety glasses

B. Procedure

1. Put on safety glasses.
2. Disconnect power source to system.
3. Mount humidistat next to thermostat or on return plenum.
4. Check transformer and volt-ampere rating.
5. Install low voltage wiring and relay in accordance with manufacturer's instructions.

(NOTE: The schematic in Figure 1 is included to show wiring for typical low voltage controls.)

JOB SHEET #1

FIGURE 1

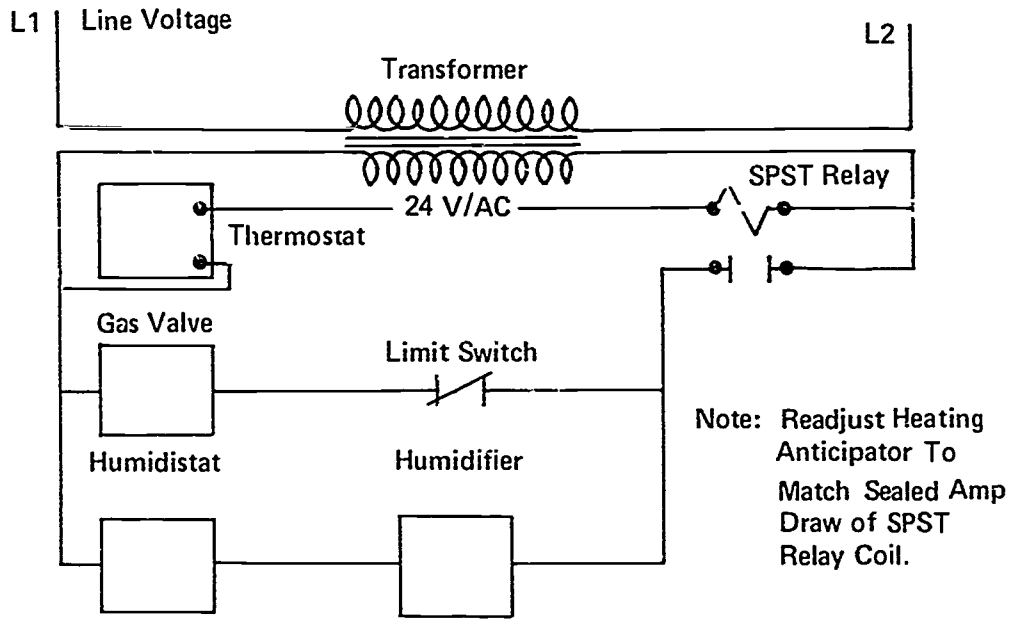

4. Mount humidifier according to manufacturer's instructions.
 5. Install saddle valve in cutoff.
(NOTE: Check local codes.)
 6. Connect cutoff to humidifier with copper tubing.
 7. Connect electrical components.
 8. Reconnect power source.
 9. Run system and humidifier long enough to verify correct operation.
- Have your instructor evaluate your work.

**RESIDENTIAL AIR TREATMENT
UNIT IV****JOB SHEET #2 — INSTALL AN ELECTRONIC FILTER****A. Tools and equipment**

1. Electronic filter and accessories
2. Aviation snips
3. Sheet metal screws as needed
4. Screwdriver
5. 1/4" nut driver
6. Heating system as selected by instructor
7. Safety glasses

B. Procedure

1. Put on safety glasses.
 2. Disconnect system power source.
 3. Mount electronic filter in return air passage.
(NOTE: Follow manufacturer's instructions carefully.)
 4. Connect electrical supply to filter according to manufacturer's instructions.
 5. Reconnect system power source.
 6. Run system with filter long enough to verify correct operation.
- Have your instructor evaluate your work.

**RESIDENTIAL AIR TREATMENT
UNIT IV**

**PRACTICAL TEST #1
JOB SHEET #1 — INSTALL A HUMIDIFIER
WITH LOW VOLTAGE CONTROLS**

Student's name _____ Date _____

Evaluator's name _____ Attempt no. _____

Student instructions: When you are ready to perform this task, ask you instructor to observe the procedure and complete this form. All items listed under "Process Evaluation" must receive a "yes" for you to receive an overall performance evaluation.

PROCESS EVALUATION

(EVALUATOR NOTE: Place a check mark in the "Yes" or "No" blanks to designate whether or not the student has satisfactorily achieved each step in this procedure. If the student is unable to achieve this competency, have the student review the materials and try again.)

The student:	YES	NO
1. Disconnected power safely.	<input type="checkbox"/>	<input type="checkbox"/>
2. Installed low voltage wiring per schematic.	<input type="checkbox"/>	<input type="checkbox"/>
3. Mounted humidifier to manufacturer's specifications.	<input type="checkbox"/>	<input type="checkbox"/>
4. Installed a saddle valve.	<input type="checkbox"/>	<input type="checkbox"/>
5. Connected cutoff to humidifier.	<input type="checkbox"/>	<input type="checkbox"/>
6. Reconnected power source.	<input type="checkbox"/>	<input type="checkbox"/>
7. Ran system to verify operation.	<input type="checkbox"/>	<input type="checkbox"/>

Evaluator's comments: _____

JOB SHEET #1 PRACTICAL TEST

PRODUCT EVALUATION

(EVALUATOR NOTE: Rate the student on the following criteria by circling the appropriate numbers. Each item must be rated at least a "3" for mastery to be demonstrated. (See performance evaluation key below.) If the student is unable to demonstrate mastery, student materials should be reviewed and another test procedure must be submitted for evaluation.)

Criteria:

Low voltage wiring installation	4	3	2	1
Humidifier installation	4	3	2	1
Saddle valve and cutoff installation	4	3	2	1
Safe working procedures	4	3	2	1

EVALUATOR'S COMMENTS: _____

PERFORMANCE EVALUATION KEY

- 4 — **Skilled** — Can perform job with no additional training.
- 3 — **Moderately skilled** — Has performed job during training program; limited additional training may be required.
- 2 — **Limited skill** — Has performed job during training program; additional training is required to develop skill.
- 1 — **Unskilled** — Is familiar with process, but is unable to perform job.

(EVALUATOR NOTE: If an average score is needed to coincide with a competency profile, total the designated points in "Product Evaluation" and divide by the total number of criteria.)

**RESIDENTIAL AIR TREATMENT
UNIT IV**

**PRACTICAL TEST #2
JOB SHEET #2 — INSTALL AN ELECTRONIC FILTER**

Student's name _____ Date _____

Evaluator's name _____ Attempt no. _____

Student instructions: When you are ready to perform this task, ask your instructor to observe the procedure and complete this form. All items listed under "Process Evaluation" must receive a "yes" for you to receive an overall performance evaluation.

PROCESS EVALUATION

(EVALUATOR NOTE: Place a check mark in the "Yes" or "No" blanks to designate whether or not the student has satisfactorily achieved each step in this procedure. If the student is unable to achieve this competency, have the student review the materials and try again.)

The student:	YES	NO
1. Disconnected power safely.	<input type="checkbox"/>	<input type="checkbox"/>
2. Mounted electronic filter in return air passage.	<input type="checkbox"/>	<input type="checkbox"/>
3. Connected electrical supply to specifications.	<input type="checkbox"/>	<input type="checkbox"/>
4. Reconnected power source.	<input type="checkbox"/>	<input type="checkbox"/>
5. Ran system to verify operation.	<input type="checkbox"/>	<input type="checkbox"/>

Evaluator's comments. _____

JOB SHEET #2 PRACTICAL TEST

PRODUCT EVALUATION

(EVALUATOR NOTE: Rate the student on the following criteria by circling the appropriate numbers. Each item must be rated at least a "3" for mastery to be demonstrated. (See performance evaluation key below.) If the student is unable to demonstrate mastery, student materials should be reviewed and another test procedure must be submitted for evaluation.)

Criteria:				
Electronic air filter installation	4	3	2	1
Electrical supply connection	4	3	2	1
Operational verification	4	3	2	1
Safe working procedures	4	3	2	1

EVALUATOR'S COMMENTS: _____

PERFORMANCE EVALUATION KEY

- 4 — **Skilled** — Can perform job with no additional training.
- 3 — **Moderately skilled** — Has performed job during training program; limited additional training may be required.
- 2 — **Limited skill** — Has performed job during training program; additional training is required to develop skill.
- 1 — **Unskilled** — Is familiar with process, but is unable to perform job.

(EVALUATOR NOTE: If an average score is needed to coincide with a competency profile, total the designated points in "Product Evaluation" and divide by the total number of criteria.)

RESIDENTIAL AIR TREATMENT UNIT IV

TEST

Name _____ Score _____

1. Match terms on the right with their correct definitions.

- | | | | |
|---------|---|-----|-------------------------|
| _____a. | A unit of linear measurement which is one thousandth of a millimeter | 1. | Particulates |
| _____b. | A control for regulating humidity in conditioned air | 2. | RH |
| _____c. | An electric heating element in a water container | 3. | Micron |
| _____d. | A filter which contains matted or porous material for removing foreign particles from conditioned air | 4. | Aeroallergens |
| _____e. | Minute particles of various solid substances in the air | 5. | Humidistat |
| _____f. | Airborne substances which cause allergies in humans | 6. | Ionization |
| _____g. | Relative humidity; the measurement of moisture in the air | 7. | Immersion heater |
| _____h. | Process of breaking a substance into positive and negative particles or charges | 8. | Impingement type filter |
| _____i. | Device for exhausting stale air by bringing in fresh air and recovering some of the heating or cooling that normally would be lost in the process | 9. | Air-to-air exchanger |
| _____j. | The addition of chemicals to control bacteria in humidifiers that have a standing water supply | 10. | Radon |
| _____k. | The reduction of mineral deposit build-up with use of special filters or chemicals in certain types of humidifiers | 11. | Descaling |
| _____l. | A filtering device that uses media with a charged surface to attract and collect particulate matter | 12. | Chemical control |
| _____m. | A gas that causes lung cancer; it occurs naturally as the radioactive decay of radium and is found in uranium-holding soil areas of the U.S. and Canada | 13. | Electrostatic |

TEST

2. Complete statements concerning air contaminants that affect humans. Circle the material that best completes each statement.
- a. Size
- 1) (Smaller) (larger) than 2 microns will be expelled by the lungs.
 - 2) (Smaller) (larger) than 2 microns will be retained in the lungs.
- b. Type
- 1) (Dust) (particulates)
 - 2) (Aeroallergens) (mold)
 - 3) A "tight" energy saving home may have an indoor air pollution problem such as (radon) (natural) gases and other pollutants given off by building materials.
3. Solve problems concerning advantages of maintaining proper humidity in a residence. Select the best solution to each of the following problems.
- a. As you are preparing the bill for a service call, you notice the chair you are sitting in has arms with dried up glue joints. It's a perfect time to:
- 1) Keep quiet about the condition of the customer's furniture.
 - 2) Recommend a good glue.
 - 3) Talk to the customer about the need for a humidifier.
- b. On a service call, you walk across a carpet, reach for the hall doorway knob and immediately get a shock. It's your immediate clue that:
- 1) The door knob has been too highly polished.
 - 2) Static electricity in floor coverings indicates a lack of humidity.
 - 3) The carpet is new.
- c. On a service call, you notice excess dust around the equipment you are working on. It's a good time to talk to the customer about:
- 1) How hard dust is on electrical equipment.
 - 2) How dust indicates a lack of proper humidity and the advantages of correcting the problem.
 - 3) How setting a pan of water on the kitchen range can help keep dust down.
4. Select from the following list those factors which affect humidity in a residence by placing an "X" beside each true statement.
- ___ a. Outside air temperature
- ___ b. Temperature of conditioned air
- ___ c. Appliance use and food preparation
- ___ d. Number of occupants and activities
- ___ e. Plumbing and water usage

TEST

- ____f. Ground water level
- ____g. Size of the lot the residence is built on
5. Complete the following chart showing features of common types of residential filtering equipment.

Type	Permanent Filter	Throw-away Filter	Electronic	Electrostatic
Initial cost	average	low	a. _____	average
Filter source	adhesive coating	adhesive screen-like fibers	b. _____ _____ _____	opposing electrostatically charged elements with air passing over media
Service or maintenance	average: clean and coat plate	simple: replace filter	c. _____ _____	average: wash media
Operating cost	average	low	d. _____	low
Effectiveness	good	average	e. _____	good

6. Select true statements concerning the operation of an electronic air cleaner. Place an "X" beside each true statement.
- ____a. Return air first passes through a pre-filter to remove larger particles.
- ____b. Partially filtered air enters an ionized field.
- ____c. A wire grid with high positive voltage charges the particles in the air.
- ____d. Negatively charged plates attract the particles that have been positively charged.
- ____e. The particles are immediately washed off the collector plates.
- ____f. Filtered air is ready to be conditioned by heating or cooling system.
7. Select true statements concerning operation of a dehumidifier. Place an "X" beside each true statement.
- ____a. Outside air is drawn into the unit by a blower.
- ____b. Air is cooled as it passes over the evaporator coil.
- ____c. Water vapor in the air condenses as it is cooled below its dew point.
- ____d. Condensation collects on the evaporator and drips into a collector tray and is removed.

TEST

- _____e. The cooled air is passed over the condenser coil to further cool it to a comfortable RH.
- _____f. Treated air is blown into the room or ductwork.
8. Select true statements concerning the operation of a typical humidifier with a forced air furnace by placing an "X" beside each true statement.
- _____a. The humidifier is installed on the return air plenum or duct and connected to the supply air plenum with flexible pipe.
- _____b. The by-passed supply air flows over a moist foam filter which rotates in a water reservoir.
- _____c. The moistened warm air reenters the air stream on the supply air side of the furnace.
- _____d. A humidifier with a separate fan is controlled by a thermostat.
9. Solve problems concerning air-to-air exchangers. Select the best solution for each of the following problems.
- a. On a service call, your customer complains that the family seemed to have colds and runny noses all winter long. How should you respond?
- 1) Tell the customer that everybody has colds and runny noses in the winter.
 - 2) Recommend a good cold medicine.
 - 3) Suggest that there may be a problem with indoor contaminants and that an air-to-air exchanger might solve the problem.
- b. You have a friend who must move into a new house. On your first visit here, you notice the air seems to be stuffy. What do you suspect?
- 1) A house so tightly built that the HVAC system is literally recycling indoor contaminants.
 - 2) That the windows haven't been opened often enough
 - 3) That the air conditioner probably needs checking.
- c. You know a family that is going to have a new house built and they start talking to you about HVAC equipment and what to install. It's a good time to:
- 1) Push the brand of equipment you're selling.
 - 2) Recommend the equipment handled by the company you work for, but also check local codes to see if forced ventilation is required.
 - 3) Recommend they talk to several different dealers before making a decision.

TEST

10. Complete statements concerning radon monitoring. Circle the material that best completes each statement.
- a. Radon is a radioactive gas that comes from the natural breakdown of radium and is found in high concentrations in soils and rocks containing (uranium) (lead).
 - b. Radon enters homes through cracks in walls and floors, sometimes in the water supply, through porous concrete, and especially through (basements) (rooms) with cracked walls or floors.
 - c. In areas with high-risk radon potential, a preliminary radon check should be made (prior to the) (at the time of) installation of HVAC equipment.
 - d. To check for the presence of radon, use a charcoal canister or an alpha track detector; they are both inexpensive and (readily available) (can be ordered) at local hardware and other stores.
 - e. If a canister or alpha track detector indicates a presence of radon, the homeowner should contact a regional office of the Environmental Protection Agency or the (local HVAC dealer) (state radiation protection service).

(NOTE: If the following activities have not been accomplished prior to the test, ask your instructor when they should be completed.)

11. Demonstrate the ability to:
- a. Install a humidifier with low voltage controls. (Job Sheet #1)
 - b. Install an electronic air cleaner. (Job Sheet #2)

**RESIDENTIAL AIR TREATMENT
UNIT IV****ANSWERS TO TEST**

1. a. 3 e. 1 i. 9 m. 10
b. 5 f. 4 j. 12
c. 7 g. 2 k. 11
d. 8 h. 6 l. 13
2. a. Size
1) Larger
2) Smaller
b. Type
1) Particulates
2) Aeroallergens
3) Radon
3. a. 3)
b. 2)
c. 2)
4. a, b, c, d, e
5. a. High
b. Opposing charged elements and primary fiber filter
c. Average wash elements
d. High
e. Excellent
6. a, b, c, d, f
7. b, c, d, f
8. a, b
9. a. 3
b. 1
c. 2

ANSWERS TO TEST

10.
 - a. Uranium
 - b. Basements
 - c. Prior to the
 - d. Readily available
 - e. State radiation protection service

11.
 - a. Evaluated according to criteria in Practical Test #1
 - b. Evaluated according to criteria in Practical Test #2

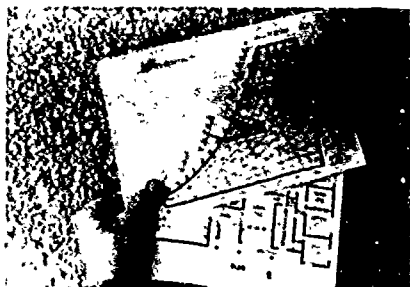

PSYCHROMETRICS FOR LIGHT COMMERCIAL HVAC UNIT V

UNIT OBJECTIVE

After completion of this unit, the student should be able to relate specific humidity, specific volume, and enthalpy to their applications in light commercial HVAC design and troubleshooting. The student should also be able to prepare a load triangle for a selected light commercial installation. These competencies will be evidenced by completing the procedures outlined in the assignment and job sheets and by scoring a minimum of 85 percent on the unit test.

SPECIFIC OBJECTIVES

After completion of this unit, the student should be able to:

1. Match terms related to psychrometrics for light commercial HVAC with their correct definitions.
2. Select true statements concerning using a psychrometric chart for light commercial applications.
3. Select true statements concerning specific humidity.
4. Complete statements concerning enthalpy.
5. Complete statements concerning specific volume.
6. Select true statements concerning the load triangle.
7. Determine relative humidity when dry bulb and wet bulb temperatures are known. (Assignment Sheet #1)
8. Determine dew point and enthalpy when dry bulb and wet bulb temperatures are known. (Assignment Sheet #2)
9. Determine the condition of air presented to the evaporator coil when outside air for ventilation is mixed with room return air. (Assignment Sheet #3)
10. Plot a load triangle on a psychrometric chart when return and supply air dry bulb/wet bulb temperatures are known. (Assignment Sheet #4)
11. Demonstrate the ability to calculate a load triangle for a given light commercial installation. (Job Sheet #1)

**PSYCHROMETRICS FOR LIGHT COMMERCIAL INSTALLATION
UNIT V**

SUGGESTED ACTIVITIES

- A. Obtain additional materials and/or invite resource people to class to supplement/reinforce information provided in this unit of instruction.

(NOTE: This activity should be completed prior to the teaching of this unit.)

- B. Make transparencies from the transparency masters included with this unit.
- C. Provide students with objective sheet.
- D. Discuss unit and specific objectives.
- E. Provide students with information and assignment sheets.
- F. Discuss information and assignment sheets.

(NOTE: Use the transparencies as needed to enhance the information.)

- G. Provide students with the job sheet.
- H. Discuss and demonstrate the procedures outlined in the job sheet.
- I. Integrate the following activities throughout the teaching of this unit:
1. Discuss enthalpy with students and impress on them the importance of the "enthalpy concept" in light commercial applications.
 2. Go through Handout #1 carefully and discuss the value of the load triangle as both a planning and troubleshooting tool.
 3. Meet individually with students to evaluate their progress through this unit of instruction, and indicate to them possible areas for improvement.
- J. Give test.
- K. Evaluate test.
- L. Reteach if necessary.

REFERENCES USED IN WRITING THIS UNIT

- A. Rutkowski, Hank. *Manual P First Edition, Psychrometrics: Theory & Applications*. Washington, DC 20036: Air Conditioning Contractors of America, 1985.
- B. Lang, Paul V. *Principles of Air Conditioning, Fourth Edition*. Albany, NY 12212: Delmar Publishers Inc., 1987.

**PSYCHROMETRICS FOR LIGHT COMMERCIAL HVAC
UNIT V**

INFORMATION SHEET

I. Terms and definitions

- A. **Specific humidity** — The amount of water by weight in each pound of air
- B. **Specific volume** — The volume that one pound of air occupies expressed in cubic feet
- C. **Process line** — The line connecting two points on a psychrometric chart identifying the properties of air at the beginning and end of an HVAC process
- D. **State point** — A point on a psychrometric chart showing the condition of air
- E. **Make-up air** — The replacement of exhausted air by introducing outside air through the heating or cooling equipment as opposed to introducing outside air directly into a conditioned space

II. Using a psychrometric chart for light commercial applications

- A. For residential use, a psychrometric chart provides a worksheet to determine:
 - 1. Dry bulb temperature
 - 2. Wet bulb temperature
 - 3. Dew point temperature
 - 4. Relative humidity
- B. For light commercial use, a psychrometric chart provides a worksheet to determine three other important conditions:
 - 1. Specific humidity
 - 2. Enthalpy
 - 3. Specific volume

III. Specific humidity

- A. Specific humidity is expressed in pounds of water per pounds of dry air.
- B. A pound of dry air can absorb from .001 to .025 pounds of water, so it is more convenient to use "grains" of water to measure specific humidity.

INFORMATION SHEET

- C. When "grains" are used to measure specific humidity, the numbers range from 10 to about 170 grains, and are much easier to reference on a psychrometric chart. (Figure 1)

Example: It's easier to say and think that a pound of air can absorb up to 170 grains of water than to say a pound of air can absorb up to twenty-five thousandths of a pound of water.

FIGURE 1

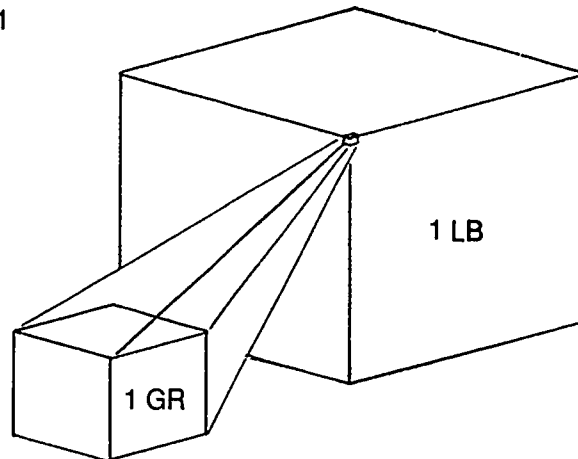

1 LB of water = 7005 grains of water

Courtesy Air Conditioning Contractors of America

- D. In planning and servicing a light commercial installation, it is important to know how much specific humidity must be removed or added to maintain a comfort zone.
- E. Because specific humidity ultimately affects relative humidity, servicing a light commercial installation becomes easier when a technician can spot trouble with specific humidity.
- F. Specific humidity is represented on a psychrometric chart with horizontal lines.

IV. Enthalpy

- A. Enthalpy is the sum of sensible and latent heat contained in air, expressed in BTUs of heat per pound of air and noted as BTU/lb.
- B. On a psychrometric chart, enthalpy lines slant from the lower right hand corner toward the upper left hand corner of the chart.
- C. Enthalpy lines are the same as wet bulb lines on a psychrometric chart. (Figure 2)

INFORMATION SHEET

FIGURE 2

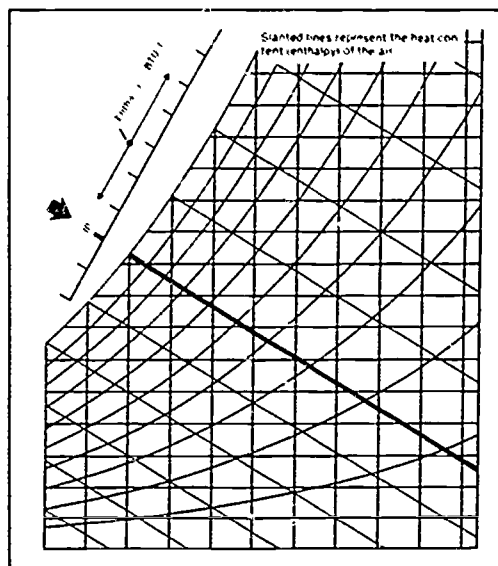

Courtesy Air Conditioning Contractors of America

- D. In design and service of light commercial installations, knowing how to measure enthalpy will determine the actual amount of BTUs being removed or added at a given time, and help identify problems related to equipment sizing.

V. Specific volume

- A. Specific volume is the volume that one pound of air occupies as expressed in cubic feet.
- B. On a psychrometric chart, specific volume lines slant sharply from the lower right hand corner toward the upper left hand corner of the chart. (Figure 3)

INFORMATION SHEET

FIGURE 3

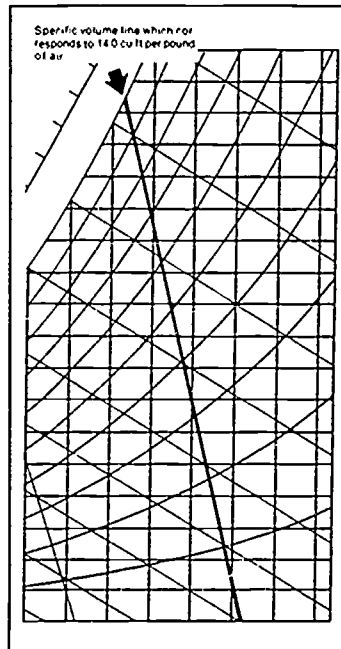

Courtesy Air Conditioning Contractors of America

- C. Since specific volume varies between 12 and 15 cu-ft/lb, it is an important consideration for understanding the basic air conditioning process, particularly in light commercial applications.

VI. The load triangle (Handout #1)

- A. A load triangle is based on the wet bulb/dry bulb temperatures of the return and supply air in a system.
- B. Starting with a state points of conditions of air at different points in a system, the load triangle provides better insight into total system performance than other approaches do.
- C. The load triangle is especially useful in light commercial HVAC troubleshooting because it can be used to isolate complex problems with latent/sensible heat balances that are difficult to determine by other methods.
- D. Being able to prepare a load triangle on a psychrometric chart will provide a technician with a better understanding of HVAC basics and provide a valuable troubleshooting tool.
- E. Make-up air requirements are easier to determine when the latent/sensible loads are clearly stated.

PSYCHROMETRICS FOR LIGHT COMMERCIAL HVAC UNIT V

HANDOUT #1 — PREPARING A LOAD TRIANGLE

Purpose

Much troubleshooting in light commercial installations can be accomplished with the same tools and instruments used to troubleshoot residential systems. Checking current draw and operating pressures can quickly determine the condition of a compressor and tell us whether the system is performing below manufacturer's design standards. In light commercial HVAC, capacity problems can become complex, and when they do, the preparation of a load triangle on a psychrometric chart is frequently the best way to find and solve the problem.

The Load Triangle

Follow along on Figure 1 that accompanies this handout as we go through the steps in preparing a load triangle. The first step is to plot the dry bulb and wet bulb temperatures for the return air entering the evaporator coil and the supply air leaving the evaporator coil. The return air dry bulb/wet bulb temperature should be marked as state point A. The supply air dry bulb/wet bulb temperature should be marked as state point B. Next, connect A and B with a straight line to form a process line. Now, draw a horizontal line from point B straight across to a point directly below point A. Label this state point C, and then connect A and C with a straight line. That's the basic load triangle, but we need to create a mirror of the triangle on the enthalpy scale. Draw a straight line from C to the enthalpy scale using the wet bulb lines as a guide. Continue by drawing straight lines from A and B to the enthalpy scale using the appropriate wet bulb lines as guides.

Interpreting the Load Triangle

Let's closely examine the load triangle in Figure 1. The legs of the triangle, A to C, and B to C, have special significance. The A to C leg is latent heat. The B to C leg is sensible heat. Note how the process line from B to A forms the hypotenuse of a right triangle. This line represents the sum of latent and sensible heat, in other words, enthalpy or total load.

Interpreting the Enthalpy Scale

Note how the process line or hypotenuse is mirrored on the enthalpy scale of the psychrometric chart. On the enthalpy scale, point A to C is the latent part of the total heat load while point B to C is the sensible part of the total heat load.

Putting the load Triangle to Work

The information on a properly prepared load triangle must be used with a special formula which is:

HANDOUT #1

(QT) Total Load = 4.45 (constant) × CFM × Enthalpy Difference

The 4.45 constant is an unchanging value from basic laws of physics as they apply to air conditioning processes. In other words, the 4.45 remains the same when you work with a load triangle, regardless of what any other figures may be. The enthalpy difference is determined by subtracting the supply air from the return air on the enthalpy scale. In our example, return air is 31 BTU/lb, supply air is 24.5 BTU/lb, so the enthalpy difference is 31 minus 24.5, or 6.5 BTU/lb difference. What we finally need is a CFM reading, so let's assume a reading of 2,000 CFM. Now we can really put the formula to work because we know everything but QT (total load)!

$$4.45 \times 2,000 \times 6.5 = 57,850 \text{ Btuh}$$

Putting the Load Triangle to Work

The load triangle provides the information needed to immediately determine if the system is performing up to capacity. Another advantage of the load triangle is that we can quickly determine how much of the load is latent heat and how much is sensible heat. In fact, subtracting C from A on the enthalpy scale gives latent heat in BTU/lb, and subtracting B from C give sensible heat in BTU/lb. Remember that specific humidity is part of latent heat and can be managed with moisture removal. In other words, latent heat is a dehumidification process. By ratio, latent heat removal accounts for less work in a system than sensible heat removal. Let's see how that could affect things. Suppose a manufacturer's total load were 48,000 BTU/hr with 14,400 BTU/hr required for latent heat removal, and 33,600 required for sensible heat removal. The unit may be delivering the full 48,000 BTU/hr for the total load, but if latent heat removal cannot be handled by the 14,400 BTU/hr specifications, we know there's a problem and exactly where the problem is. Perhaps blower speed can be adjusted within manufacturer's specifications to change CFM, or it may be that the system is too small to handle the latent heat load and a larger unit may be required.

Conclusion

Complex problems caused by improper latent/sensible heat removal ratios can best be isolated with the use of a properly prepared load triangle on a psychrometric chart.

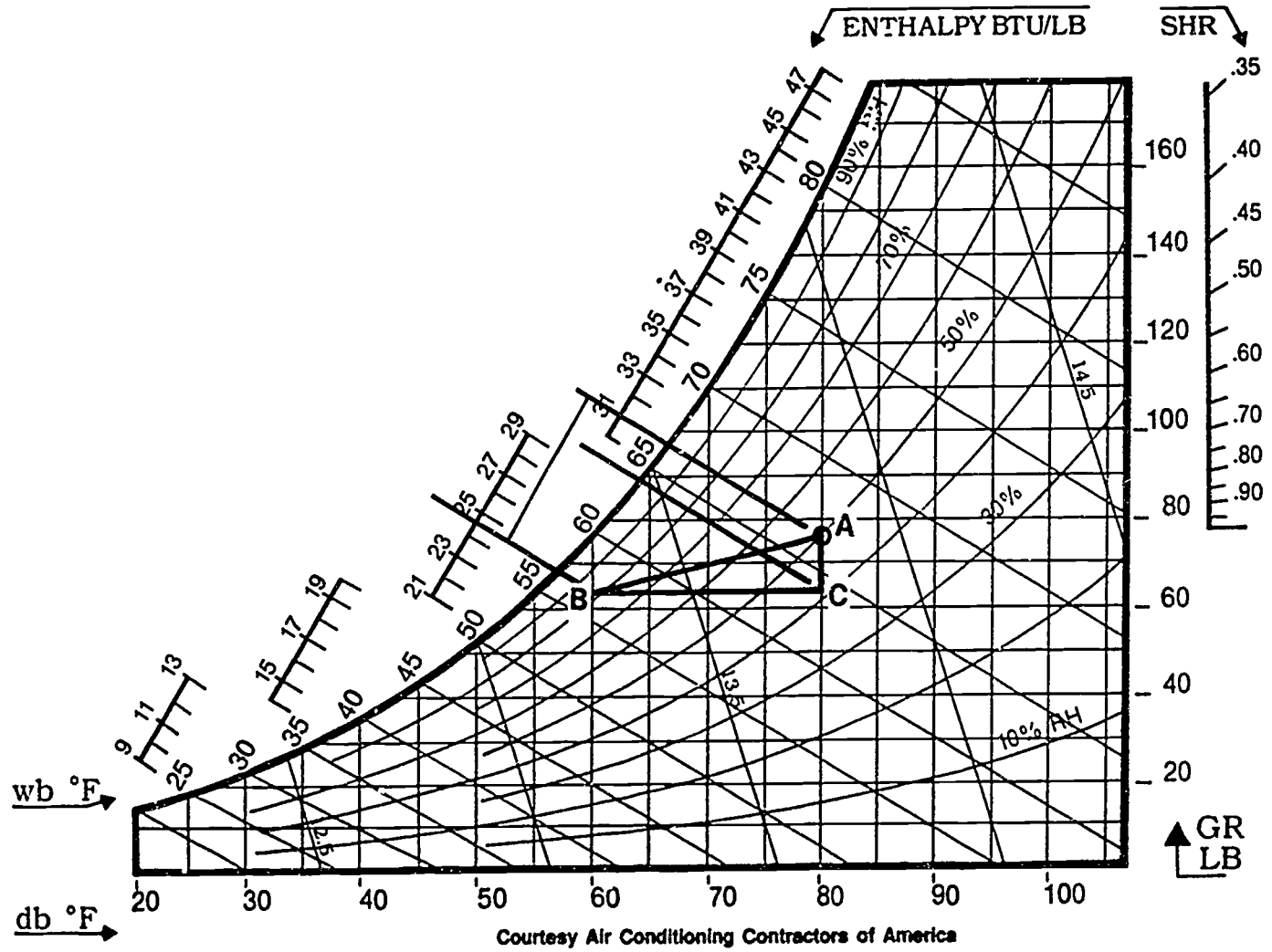

Courtesy Air Conditioning Contractors of America

FIGURE 1

HANDOUT #1

298

297

**PSYCHROMETRICS FOR LIGHT COMMERCIAL HVAC
UNIT V**

**ASSIGNMENT SHEET #1 — DETERMINE RELATIVE HUMIDITY WHEN
DRY BULB AND WET BULB TEMPERATURES ARE KNOWN**

Directions: Complete the chart in Figure 1 by plotting the lines to determine relative humidity with a dry bulb of 75°F and a wet bulb of 60°F.

Procedure:

1. Use a ruler and pencil to draw a vertical line up the chart from the point of the dry bulb temperature scale that reads 75°.
 2. Draw a diagonal line from the point on the wet bulb scale that reads 60°.
 3. The relative humidity is determined by the point of intersection of the dry bulb and wet bulb lines, and this gives a relative humidity reading of approximately _____ percent.
- Have your instructor evaluate your work.

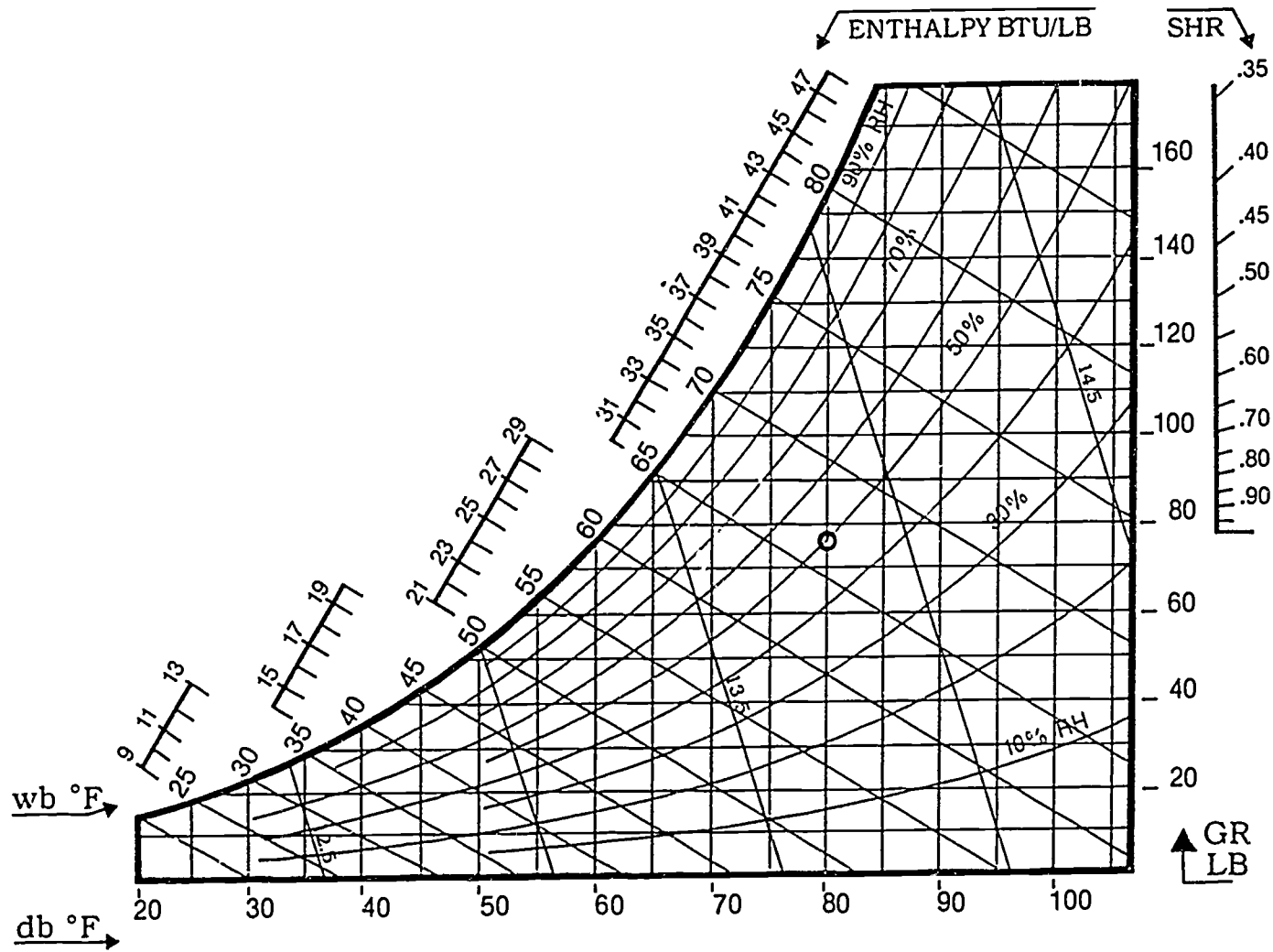

Courtesy Air Conditioning Contractors of America

FIGURE 1

ASSIGNMENT SHEET #1

PSYCHROMETRICS FOR LIGHT COMMERCIAL HVAC
UNIT V

ASSIGNMENT SHEET #2 — DETERMINE DEW POINT AND ENTHALPY
WHEN DRY BULB AND WET BULB TEMPERATURES ARE KNOWN

Directions: Complete the chart by plotting the correct lines to determine the dew point and enthalpy with 75° dry bulb and 60° wet bulb.

Procedure:

1. After establishing the state point as in assignment #1, draw a horizontal line from that point toward the left to the saturation line.
 2. The point on the saturation line gives a dew point of _____ °F.
 3. Draw a line from the state point toward the upper left following the wet bulb line through the saturation line to the enthalpy scale.
 4. The point on the enthalpy scale gives a total heat (sensible plus latent) reading of _____ BTU/lb.
- Have your instructor evaluate your work.

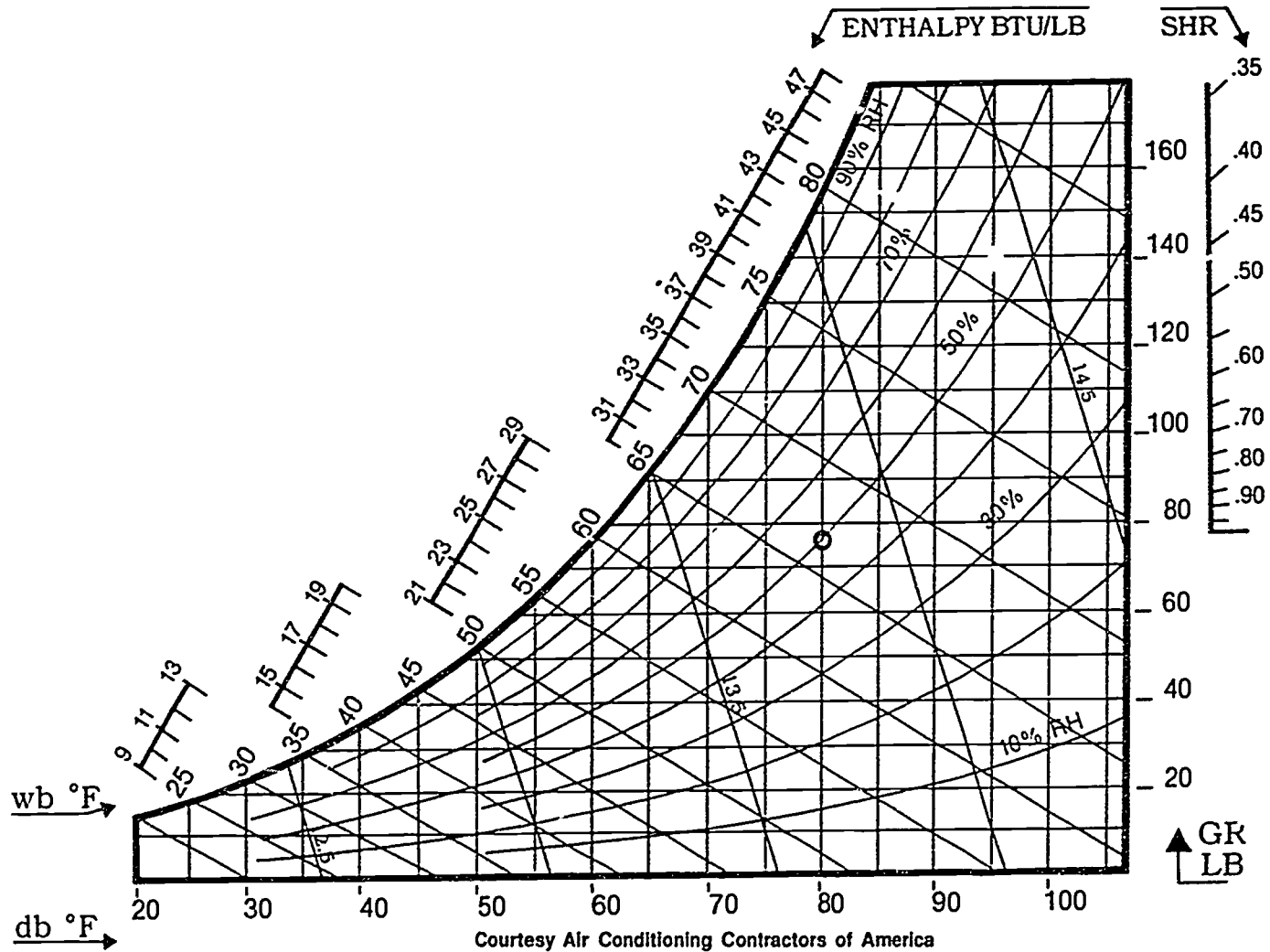

Courtesy Air Conditioning Contractors of America

FIGURE 1

ASSIGNMENT SHEET #2

**PSYCHROMETRICS FOR LIGHT COMMERCIAL HVAC
UNIT V**

**ASSIGNMENT SHEET #3 — DETERMINE THE CONDITION OF AIR PRESENTED TO AN
EVAPORATOR COIL WHEN OUTSIDE AIR FOR VENTILATION IS MIXED WITH
ROOM RETURN AIR**

Directions: Complete the chart by plotting the correct lines when 20% outside air at 90° dry bulb and 78° wet bulb is mixed with room return air at 80° dry bulb and 67° wet bulb.

Procedure:

1. Establish state point "A" (outside air) and state point "B" (room return air) by the methods shown. Draw a line between "A" and "B".
 2. Establish state point "C" by making a point on the chart approximately 20% of the distance between "A" and "B", starting from point "B". The condition of the mixed air is:
 - A. Dry bulb _____
 - B. Wet bulb _____
 - C. Relative Humidity _____
 - D. Dew point _____
 - E. Enthalpy _____
 - F. Specific volume _____
 - G. Specific humidity _____
- Have your instructor evaluator your work.

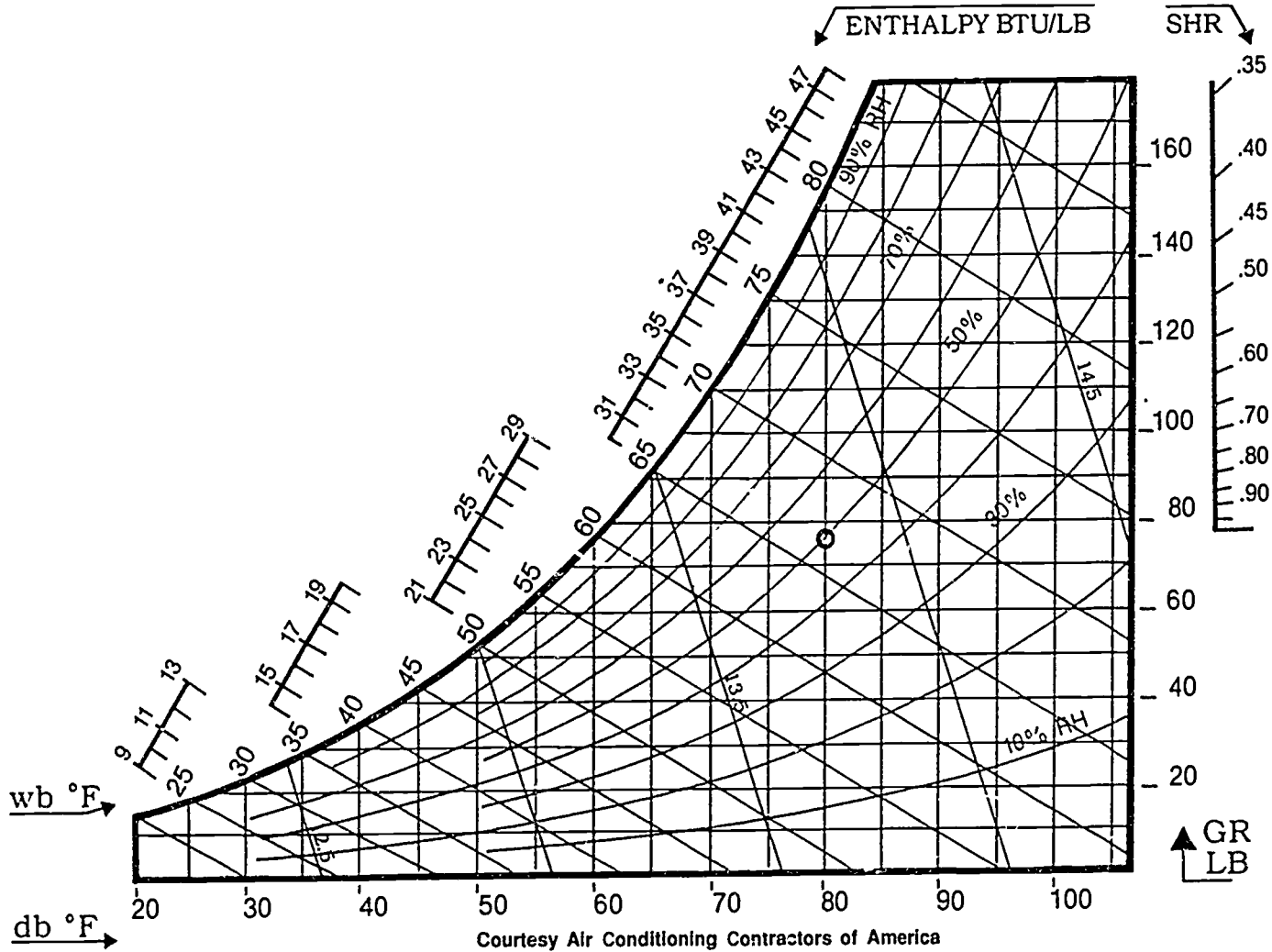

Courtesy Air Conditioning Contractors of America

FIGURE 1

ASSIGNMENT SHEET #3

**PSYCHROMETRICS FOR LIGHT COMMERCIAL HVAC
UNIT V**

**ASSIGNMENT SHEET #4 — PLOT A LOAD TRIANGLE ON A PSYCHROMETRIC
CHART WHEN RETURN AND SUPPLY AIR WET BULB/DRY BULB
TEMPERATURES ARE KNOWN**

Directions: Complete the chart by drawing a load triangle on the chart when the return air is 80°F dry bulb, 67°F wet bulb and the supply air is 61° dry bulb, 57° wet bulb.

Procedure:

1. Establish the return air, point "A" on the chart (initial).
2. Establish the supply air, point "B" on the chart (final).
3. Draw a straight line between them known as the process line and forms the hypotenuse of a right triangle representing the total load.
4. Draw a horizontal line from point "B" to the right, stopping directly below point "A".
5. Draw a vertical line down from "A" connecting with the horizontal line from point "B", forming a right triangle. The legs of the triangle represent the sensible and latent loads.
6. If the CFM is 2000 find the total load using the following equation.

(QT) total load = 4.45 (constant) × CFM × enthalpy difference

QT = _____

- Have your instructor evaluate your work.

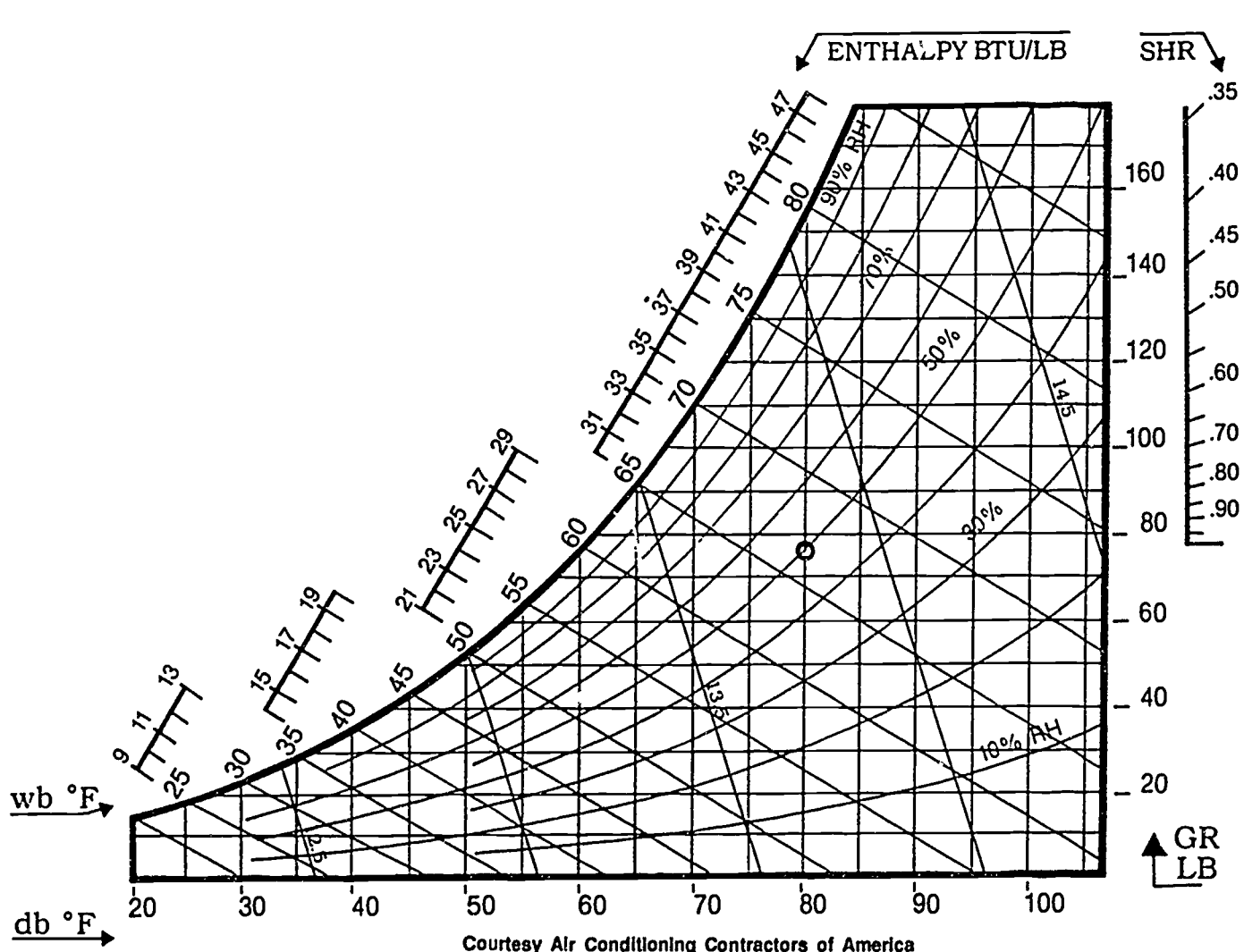

Courtesy Air Conditioning Contractors of America

FIGURE 1

ASSIGNMENT SHEET #4

PSYCHROMETRICS FOR LIGHT COMMERCIAL HVAC
UNIT V

ANSWERS TO ASSIGNMENT SHEETS

Assignment Sheet #1

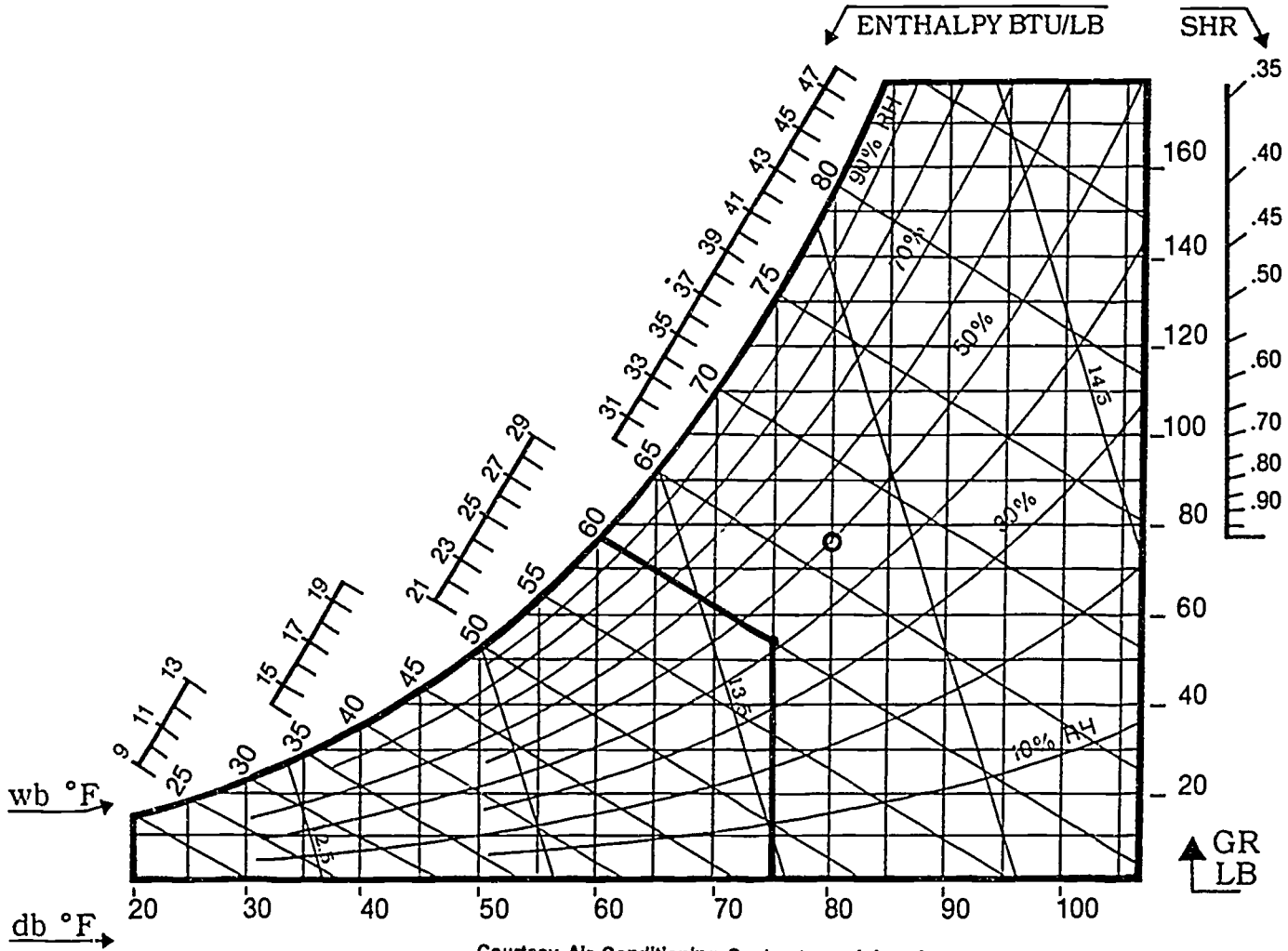

Courtesy Air Conditioning Contractors of America

ANSWERS TO ASSIGNMENT SHEETS

Assignment Sheet #2

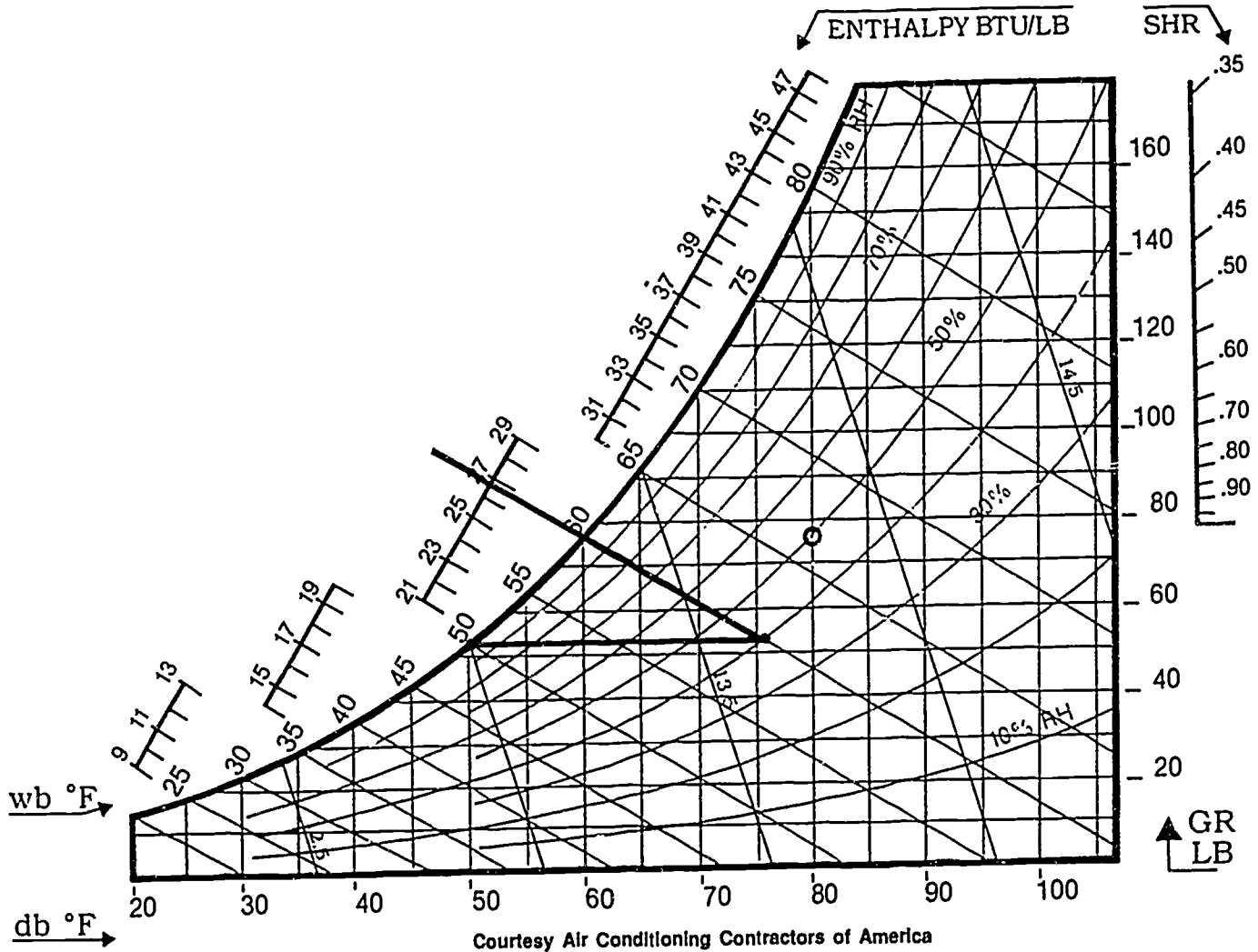

Courtesy Air Conditioning Contractors of America

240

240

ANSWERS TO ASSIGNMENT SHEETS

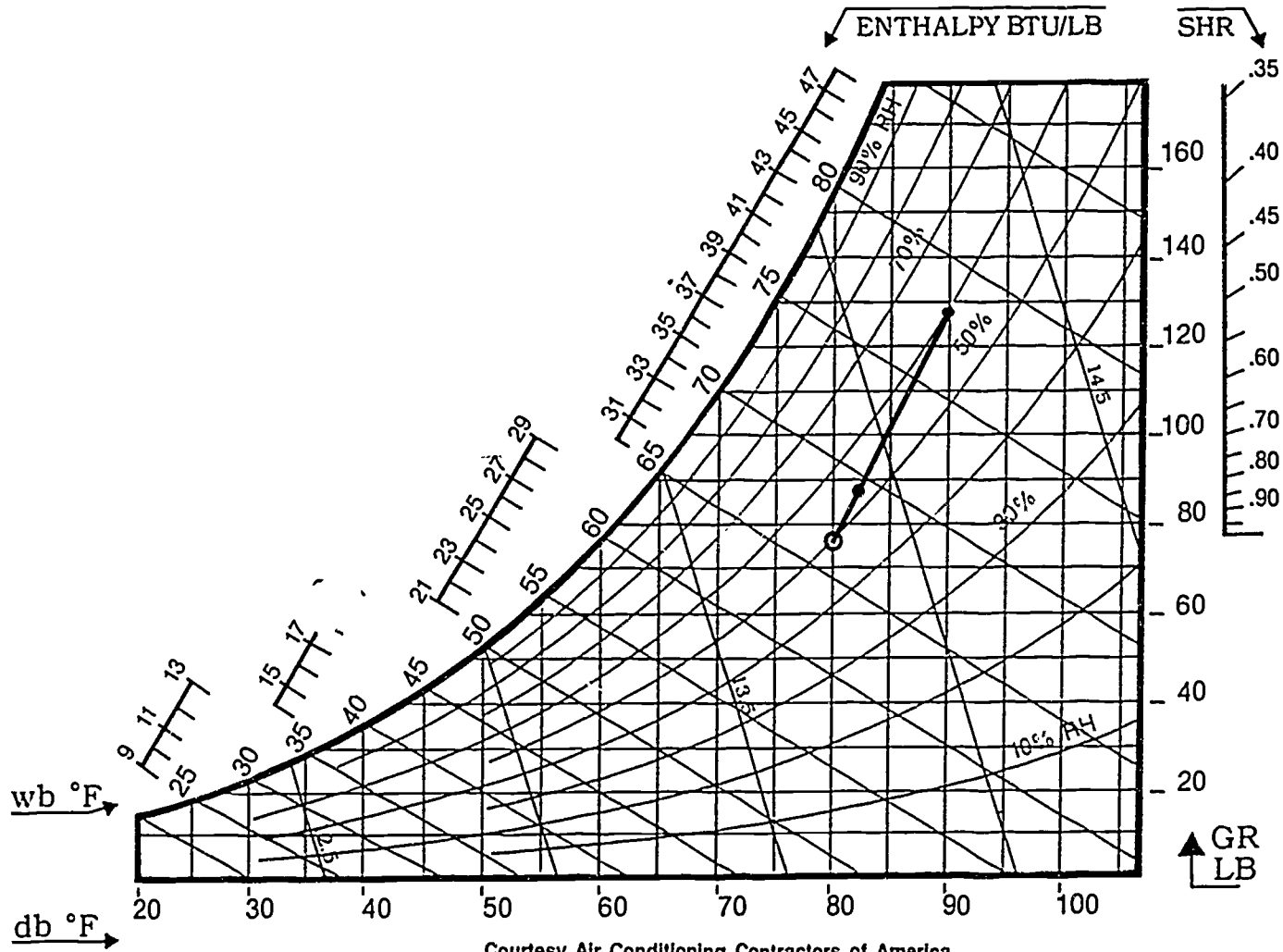

Courtesy Air Conditioning Contractors of America

GR
LB

ANSWERS TO ASSIGNMENT SHEETS

Assignment Sheet #4

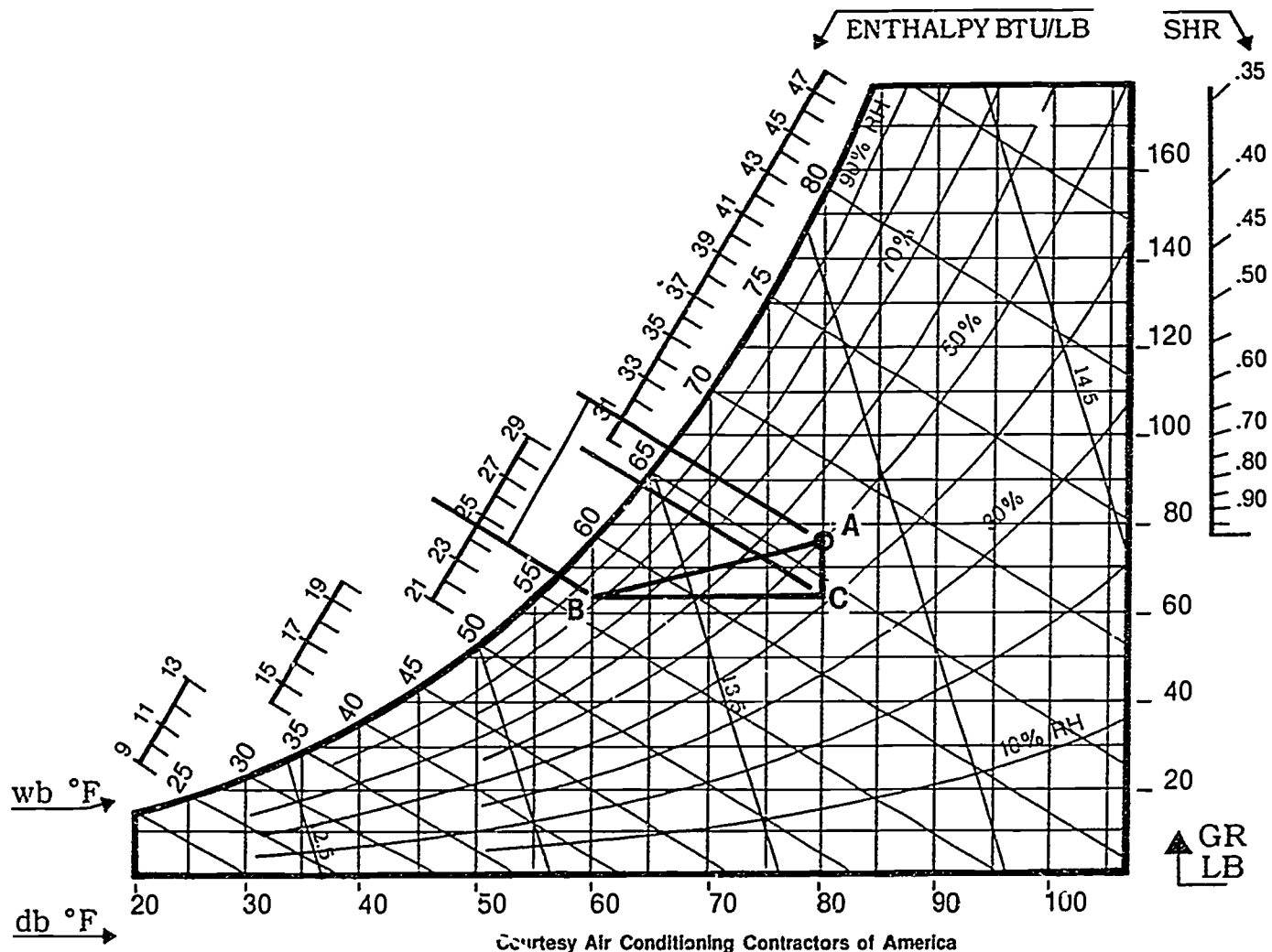

Courtesy Air Conditioning Contractors of America

246

247

**PSYCHROMETRICS FOR LIGHT COMMERCIAL HVAC
UNIT V**

**JOB SHEET #1 — CALCULATE A LOAD TRIANGLE FOR A GIVEN LIGHT
COMMERCIAL HVAC INSTALLATION**

- A. Tools and equipment
1. Sling psychrometer or fan psychrometer
 2. Inclined manometer
 3. Drill and selected bit
 4. Duct tape
 5. Psychrometric chart (included here)
 6. Pencil
 7. Safety glasses
 8. Light commercial HVAC system as selected by instructor
 9. Blower performance chart for the unit selected
- B. Procedure
1. Put on safety glasses.
 2. Examine the area around the system to make sure you are working in a safe environment.
 3. Drill a hole in the supply air plenum just large enough to insert a manometer probe.
 4. Drill a hole in the return air plenum just large enough to insert a manometer probe.
 5. Insert inclined manometer probes in the supply and return ducts at the air handling equipment, and record your measurement here ____.
 6. Consult the equipment manufacturer's blower performance chart to determine approximate CFM being delivered and record here ____.
 7. Check with your instructor to make sure you have correct figures, and if you do not have to repeat your measurements, remove the probes and tape the holes you drilled in the supply and return air plenums with duct tape.

JOB SHEET #1

8. Use a sling psychrometer or a fan psychrometer to determine the wet and dry bulb temperatures for the return air:

Return air wet bulb temperature _____°F.

Return air dry bulb temperature _____°F.

9. Repeat the procedure to determine supply air temperatures:

Supply air wet bulb temperature _____°F.

Supply air dry bulb temperature _____°F.

10. Plot the return air temperature as state point A on the psychrometric chart that accompanies this job sheet.

(NOTE: Review your Assignment Sheets or Handout #1 if you have questions about this or any other step in the procedure.)

11. Plot the supply air temperature as state point B on your psychrometric chart.

12. Draw a straight process line connecting state points A and B.

13. Draw straight lines from state points A and B to the enthalpy scale, using wet bulb lines as guidelines.

14. Plot point C by drawing a straight line horizontally from state point B to a point directly below state point A.

15. Connect B-C and C-A with straight lines to form the load triangle.

16. Extend a straight line from C to the enthalpy scale using wet bulb lines as a guideline.

17. Construct a load triangle formula to determine QT (total load)

$$QT = 4.45 \times \text{CFM} \times \text{enthalpy difference}$$

$$\underline{\quad} = 4.45 \times \underline{\quad} \times \underline{\quad}$$

18. Split the QT into latent and sensible heat by subtracting C from A on the enthalpy scale to determine latent heat, and by subtracting B from C to determine sensible heat:

Latent heat _____ BTU/lbs.

Sensible heat _____ BTU/lbs.

JOB SHEET #1

19. Compare all readings with manufacturer's specifications, and note any variations that may be significant enough to indicate a problem: _____

- Have your instructor check your findings and your evaluation.
20. Clean area and return tools and equipment to proper storage.

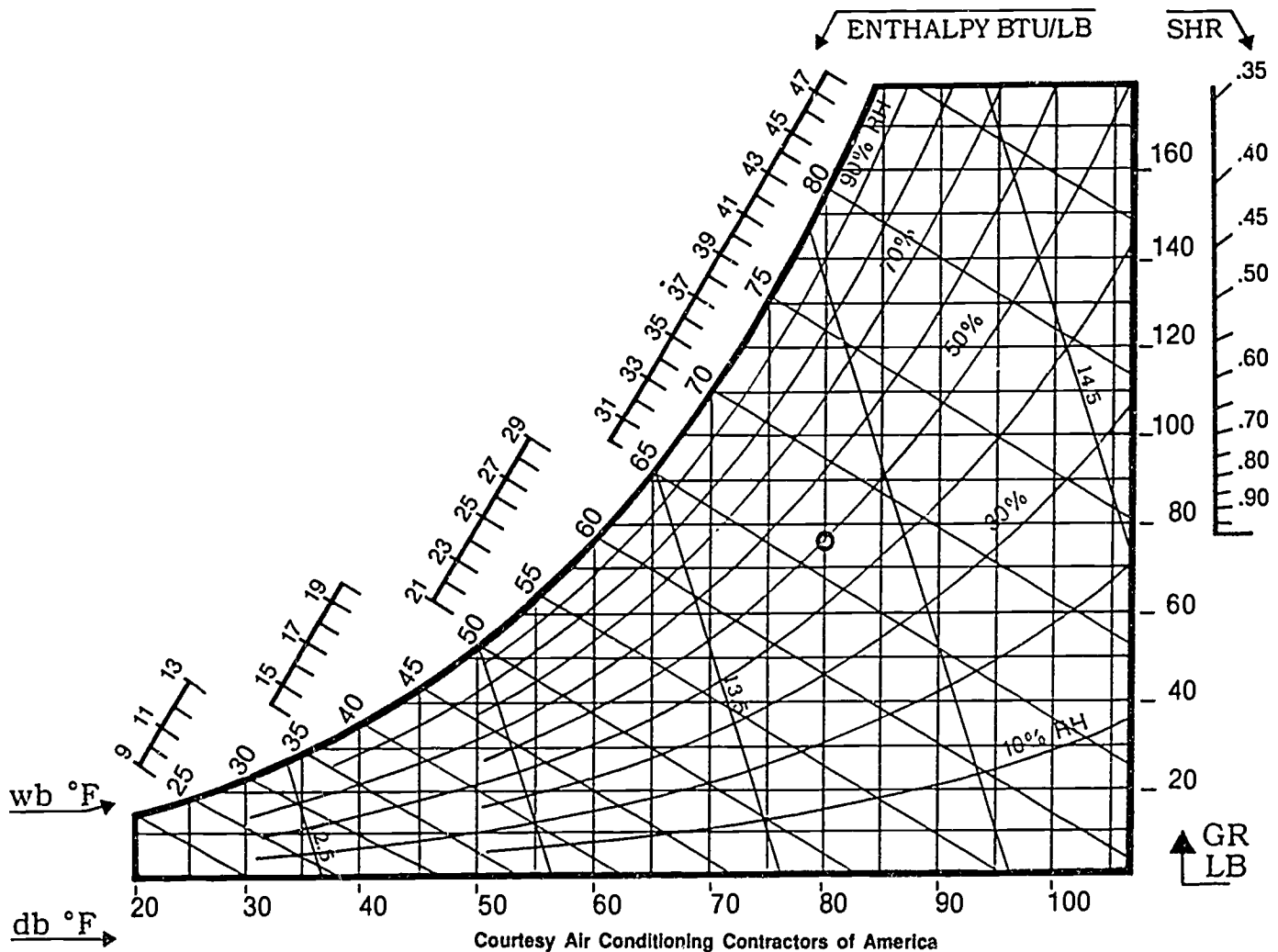

Courtesy Air Conditioning Contractors of America

FIGURE 1

JOB SHEET #1

**PSYCHROMETRICS FOR LIGHT COMMERCIAL HVAC
UNIT V**

**PRACTICAL TEST #1
JOB SHEET #1 — CALCULATE A LOAD TRIANGLE FOR A GIVEN LIGHT
COMMERCIAL HVAC INSTALLATION**

Student's name _____ Date _____

Evaluator's name _____ Attempt no. _____

Student instructions: When you are ready to perform this task, ask your instructor to observe the procedure and complete this form. All items listed under "Process Evaluation" must receive a "yes" for you to receive an overall performance evaluation.

PROCESS EVALUATION

(EVALUATOR NOTE: Place a check mark in the "Yes" or "No" blanks to designate whether or not the student has satisfactorily achieved each step in this procedure. If the student is unable to achieve this competency, have the student review the materials and try again.)

The student:	YES	NO
1. Prepared safe working environment.	<input type="checkbox"/>	<input type="checkbox"/>
2. Drilled holes in supply and return air plenums.	<input type="checkbox"/>	<input type="checkbox"/>
3. Used inclined manometer to measure supply and return air.	<input type="checkbox"/>	<input type="checkbox"/>
4. Determined approximate CFM being delivered.	<input type="checkbox"/>	<input type="checkbox"/>
5. Checked wet and dry bulb temperatures for supply air and return air.	<input type="checkbox"/>	<input type="checkbox"/>
6. Constructed load triangle.	<input type="checkbox"/>	<input type="checkbox"/>
7. Determined total load.	<input type="checkbox"/>	<input type="checkbox"/>

Evaluator's comments: _____

JOB SHEET #1 PRACTICAL TEST

PRODUCT EVALUATION

(EVALUATOR NOTE: Rate the student on the following criteria by circling the appropriate numbers. Each item must be rated at least a "3" for mastery to be demonstrated. (See performance evaluation key below.) If the student is unable to demonstrate mastery, student materials should be reviewed and another test procedure must be submitted for evaluation.)

Criteria:

CFM approximation	4	3	2	1
Wet and dry bulb temperatures	4	3	2	1
Load triangle construction	4	3	2	1
Total load calculation	4	3	2	1

EVALUATOR'S COMMENTS: _____

PERFORMANCE EVALUATION KEY

- 4 — **Skilled** — Can perform job with no additional training.
- 3 — **Moderately skilled** — Has performed job during training program; limited additional training may be required.
- 2 — **Limited skill** — Has performed job during training program; additional training is required to develop skill.
- 1 — **Unskilled** — Is familiar with process, but is unable to perform job.

(EVALUATOR NOTE: If an average score is needed to coincide with a competency profile, total the designated points in "Product Evaluation" and divide by the total number of criteria.)

**PSYCHROMETRICS FOR LIGHT COMMERCIAL HVAC
UNIT V**

TEST

Name _____ Score _____

1. Match the terms on the right with their correct definitions.

<p>____a. The amount of water by weight in each pound of air</p> <p>____b. The volume that one pound of air occupies expressed in cubic feet</p> <p>____c. The line connecting two points on a psychrometric chart identifying the properties of air at the beginning and end of an HVAC process</p> <p>____d. A point on a psychrometric chart showing the condition of air</p> <p>____e. The replacement of exhausted air by introducing outside air through the heating or cooling equipment as opposed to introducing outside directly into a conditioned space</p>	<p>1. Specific volume</p> <p>2. State point</p> <p>3. Specific humidity</p> <p>4. Process line</p> <p>5. Make-up air</p>
---	--

2. Select true statements concerning using a psychrometric chart for light commercial applications. Place an "X" beside each true statement.
 - ____a. The psychrometric chart can help in determining if the HVAC unit is performing properly.
 - ____b. The psychrometric chart deals in sensible heat, so other methods need to be used concerning latent heat.
 - ____c. The psychrometric charts helps understand the air-conditioning process.

3. Select true statements concerning specific humidity. Place an "X" beside each true statement.
 - ____a. Specific humidity is expressed in pounds of water per cubic foot of dry air.
 - ____b. It is more convenient to use "grains" of water to measure specific humidity.
 - ____c. When "grains" are used the numbers range from 100 to 1700 grains.

TEST

4. Complete statements concerning enthalpy. Circle the material that best completes each statement.
- Enthalpy is the "total heat" and is expressed in BTU's (per/cubic feet) or (pounds of air).
 - Enthalpy lines are (slanted) (curved) from the lower right toward the upper left of a psychrometric chart.
 - Lines on a psychrometric chart depicting enthalpy are the same as (dry) (wet) bulb lines.
5. Complete statements concerning specific volume. Circle the material that best completes each statement.
- Specific volume is the volume that one (pound) (ounce) of air occupies as expressed in cubic feet.
 - On a psychrometric chart, specific volume lines (slant) (curve) sharply from the lower right hand corner toward the upper left.
 - Specific volume varies between (12 and 15) (8 and 10) cubic feet per pound.
6. Select true statements concerning the load triangle. Place an "X" beside each true statement.
- a. A load triangle is based on the wet bulb/dry bulb temperatures of the return and supply air in a system.
 - b. The load triangle provides better insight into total system performance than other approaches do.
 - c. The load triangle is useful except it cannot be used for solving latent/sensible heat balances.
 - d. Being able to prepare a load triangle will provide a technician with better understanding of HVAC basics and provide a valuable troubleshooting tool.
 - e. Make-up air requirements are easier to determine when the latent/sensible loads are clearly stated.

(NOTE: If the following activities have not been accomplished prior to the test, ask you instructor when they should be completed.)

- Determine relative humidity when dry bulb and wet bulb are known. (Assignment Sheet #1)
- Determine dew point and enthalpy when dry and wet bulb temperatures are known. (Assignment Sheet #2)
- Determine the condition of air presented to the evaporator coil when outside air for ventilation is mixed with room return air. (Assignment Sheet #3)

TEST

10. Plot a load triangle on a psychrometric chart when return and supply air dry bulb/wet bulb temperatures are known. (Assignment Sheet #4)
11. Demonstrate the ability to calculate a load triangle for a given light commercial installation. (Job Sheet #1)

**PSYCHROMETRICS FOR LIGHT COMMERCIAL HVAC
UNIT V****ANSWERS TO TEST**

1. a. 3
b. 1
c. 4
d. 2
e. 5
2. a, c
3. b
4. a. Pounds of air
b. Slanted
c. Wet
5. a. Pound
b. Slant
c. 12 and 15
6. a, b, d, e
7. Evaluated according to the answers to assignment sheets
8. Evaluated according to the answers to assignment sheets
9. Evaluated according to the answers to assignment sheets
10. Evaluated according to the answers to assignment sheets
11. Evaluated according to criteria in Practical Test #1

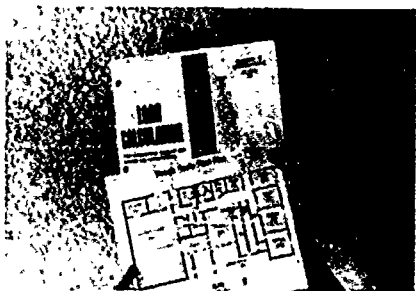

LIGHT COMMERCIAL LOAD CALCULATIONS UNIT VI

UNIT OBJECTIVE

After completion of this unit, the student should be able to use factors and tables for light commercial applications to calculate heat loss and gain in a given geographical location. These competencies will be demonstrated by completing the assignment sheets and by scoring a minimum of 85 percent of the unit test.

SPECIFIC OBJECTIVES

After completion of this unit, the student should be able to:

1. Match terms related to light commercial load calculations with their definitions.
2. Select true statements concerning *Manual N* and light commercial load calculations.
3. Select from a list load components for heat loss and heat gain in a light commercial space.
4. Complete statements concerning other sources of light commercial heat gain.
5. Complete statements concerning the winter humidification load.
6. Complete statements concerning time of day corrections.
7. List considerations for selecting equipment for a normal cooling application.
8. Select true statements concerning U values.
9. Calculate the heat gain for an office. (Assignment Sheet #1)
9. Calculate the heat loss for an office. (Assignment Sheet #2)

LIGHT COMMERCIAL LOAD CALCULATIONS UNIT VI

SUGGESTED ACTIVITIES

- A. Obtain additional materials and/or invite resource people to class to supplement/reinforce information provided in this unit of instruction.

(NOTE: This activity should be completed prior to the teaching of this unit.)
- B. Provide students with objective sheet.
- C. Discuss unit and specific objectives.
- D. Provide students with information and assignment sheets.
- E. Discuss information and assignment sheets.
- F. Provide students with Handouts #1 and #2.
- G. Discuss and demonstrate the load calculation for the Fox Furniture Store in Handout #2.
- H. Review Assignment Sheet #1 and explain how the load calculation could be treated as a zoned office.
- I. Integrate the following activities throughout the teaching of this unit:
 - 1. Arrange a field trip to have students gather information necessary to calculate a light commercial structure.
 - 2. Secure Manual "N" and form "N-1" to be used for class assignments.
 - 3. Meet individually with students to evaluate their progress through this unit of instruction, and indicate to them possible areas for improvement.
- J. Give test.
- K. Evaluate test.
- L. Reteach if necessary.

REFERENCES USED IN WRITING THIS UNIT

- A. *Manual N, Load Calculation for Commercial Summer and Winter Air Conditioning, Fourth Edition.* Washington DC 20036: Air Conditioning Contractors of America, 1988.
- B. Whitman, William C. and William M. Johnson. *Refrigeration and Air Conditioning Technology.* Albany, NY 12212: Delmar Publishers, Inc.

**LIGHT COMMERCIAL LOAD CALCULATIONS
UNIT VI**

INFORMATION SHEET

I. Terms and definitions

- A. **Block load** — The peak load for an entire building if the entire building is considered to be a single zone

(NOTE: The sum of the peak zone loads will exceed the block load because all zones do not normally peak simultaneously.)

- B. **Design load** — The load imposed on conditioning equipment when all sources of load are taken at the maximum they will occur at the same time

- C. **Make-up air** — Outside air introduced into the space through the heating or cooling equipment, replacing air that has been exhausted

- D. **Peak load** — The maximum load expected at any given hour of the year

(NOTE: Each zone will experience a peak load, but all zones do not normally peak together.)

- E. **Return air ceiling plenum** — The space between the roof and a ceiling being used as a return air plenum so that ductwork is not required for the return

- F. **Zone** — Any space in a building that requires its own controls to assure that design conditions will be maintained

II. Manual N and light commercial load calculations (Handout #1)

- A. Procedures for light commercial load calculations presented in ACCA's *Manual N* are for heating and cooling in small commercial and public assembly applications.

- B. *Manual N* calculations are primarily for summer, winter, and year round conditioning systems using unitary equipment.

- C. *Manual N* does not apply to large buildings using built-up or central station equipment for air conditioning.

- D. Where an application involves life, safety, or processes that depend on maintaining a specific indoor design condition, a consulting engineer should be employed.

III. Heat loss and heat gain in light commercial space

- A. For light commercial space, calculating heating and cooling loads requires an accurate survey of the load components in the space to be conditioned.

INFORMATION SHEET**B. Load components that must be considered include:**

1. Construction details
2. Physical size
3. Orientation of the building or space
4. Lighting
5. Occupancy
6. Appliances and equipment
7. Infiltration
8. Ventilation
9. Schedule and type of use
10. Inside conditions
11. Outside conditions

IV. Other sources of light commercial heat gain

- A. The planned use of a light commercial space will automatically mean that there will be other sources of heat gain.
- B. Heat gain from lighting can be figured two ways:
 1. Incandescent lighting can be calculated by multiplying 3.4 Btuhs per watt.
 2. Fluorescent lighting can be calculated by multiplying 4.1 Btuhs per watt.
- C. Heat gain from motors must be handled carefully:
 1. Special care must be taken to find the operating amperage of large motors or many small motors that would add heat gain.
 2. Since motors do not run continuously, a "use factor" has to be applied to heat gain calculations.
- D. Heat producing equipment such as steam tables, ranges, and fryers must be taken into account, and both sensible and latent loads must be considered.
- E. Take into consideration loads within other loads, conditioned spaces that are part of larger conditioned spaces.

INFORMATION SHEET

V. The winter humidification load

- A. The addition of moisture to humidify a space requires the expenditure of heat, and the winter humidification load must be calculated in a light commercial space.
- B. Humidification loads are based on the heat required to evaporate a pound of water, and that is approximately 1,070 BTUs.

VI. Time of day corrections

- A. The time of day that a space cooling load peaks is not always apparent.
- B. When calculating loads that peak at a time other than 3 p.m., a time of day correction must be made for outdoor conditions.

(NOTE: Refer to Handout #2 for an example of a time of day correction.)

VII. Considerations for selecting equipment for a normal cooling application

- A. Selecting equipment for a normal cooling application requires that the following should match as closely as possible:
 - 1. Total sensible load
 - 2. Total latent load
 - 3. Required air flow in CFM
- B. Remember that in a light commercial space the operation is usually intermittent, not a 24-hour activity, so light commercial equipment is not selected on the basis of an expected temperature swing as outlined in *Manual J* residential equipment selection.

VIII. U Values

- A. Since U values are used in calculating both cooling and heating loads, it is essential to know what a U value is and how to put a U value to work.
- B. A U value is based on the total resistance of a component plus the air film resistance inside and outside the component.

INFORMATION SHEET

- C. A 2 x 4 stud wall with brick veneer, 3 inches of insulation, and a dry wall interior would have a total resistance of 12.89 (sq. ft. °F hr)/Btu. (Figure 1)

FIGURE 1

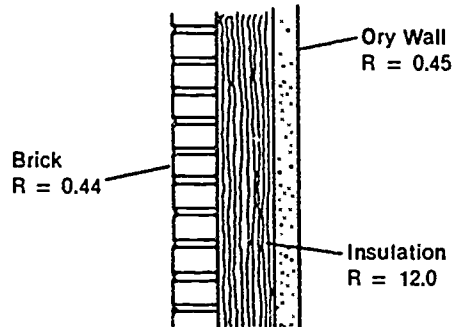

Resistance of brick	=	0.44
Resistance of insulation	=	12.00
Resistance of dry wall	=	0.45
Total resistance of wall	=	12.89 (sq. ft. °F hr)/Btu

Courtesy Air Conditioning Contractors of America

- D. To arrive at the U value, we have to add the outside air film resistance and inside air film resistance to the total wall resistance.

Example:	Total wall resistance =	12.89
	Outside air film resistance =	0.25
	Inside air film resistance =	<u>0.68</u>
	Net effective resistance =	13.82
		(sq. ft. °F hr.)/Btu.

- E. Once total resistance and outside/inside air film resistance have been added, the U value or transmission coefficient can be found by dividing 1.0 by the net effective resistance.

Example: $1.0/13.82 = 0.072 \text{ Btu}/(\text{hr. sq.ft. } ^\circ\text{F})$

- F. The U value or U factor as it is also called is multiplied by the square footage of the component which in turn is multiplied by the dry bulb temperature difference to give the transmission gain in Btuh.

Example:	Glass sq. ft.	=	1,190
	U value	=	1.04
	db TD	=	<u>15</u>
	Load	=	18,564

INFORMATION SHEET

IX. Equivalent temperature differences (ETDs)

- A. When the heat gain through a component is calculated, the effects of the sun and thermal storage must be taken into account.
- B. The sun has the same effect as increasing the temperature difference across a component and the ETD is used to calculate the heat flow.
- C. The ETD depends on orientation of the component, time of day, and construction materials, so the process has been simplified by using average ETDs which eliminate all the paperwork and calculations.
- D. The ETDs for light commercial structures are grouped by letter numbers and appear in tables in *Manual N*.

LIGHT COMMERCIAL LOAD CALCULATIONS UNIT VI

HANDOUT #1 — USING THE INFORMATION IN *MANUAL N*

Purpose:

To prepare an accurate load calculation for a light commercial structure would require such a vast array of technical and engineering data that it would be overwhelming for one person or even one company to attempt it alone. Fortunately, the tables in ACCA's *Manual N* present the engineering data required to make accurate load calculations. A review of the *Manual N* tables will help an HVAC technician appreciate the enormous contribution that ACCA and ASHRAE and other unsung organizations and people have made to the art of light commercial load calculation and equipment sizing.

Table 1

Design conditions are dictated by local climate, and that's what Table 1 is all about. Much of Table 1 is taken from ASHRAE weather data that took years to collect. The important elements are the geographical locations. Selected U.S. and Canadian cities are listed alphabetically by state or province and their latitude in degrees north of the equator. The outside design dry-bulb for winter indicates that the temperature listed WILL be exceeded for 97½% of winter heating hours. In other words, a built-in design safety factor. The same holds true for summer dry-bulb and wet-bulb temperatures. The temperatures given WILL NOT be exceeded more than 2½% of the time. The design grains are shown for spaces maintained at 55% and 50% relative humidity. These references are vital for calculating latent loads associated with infiltration and ventilation. The degree day information in Table 1 is for reference only. It is useful for some residential and heat pump calculations, but should not be used for light commercial applications.

Tables 2A through 5

Tables 2A and 2B present solar heat gain factors (SHGF) for bare glass and shaded glass. Factors are related to degrees of north latitude, time of day for standard time and whether room construction is light, medium, or heavy. Tables 3 and 4 concern themselves with shading factors for everything from blinds, roller shades, and draperies to roof overhangs. Table 5 presents heat transmission factors for glass that is clear, tinted, heat absorbing, or reflective. Since the values are presented as U values, adjustments have to be made for glass with wood or thermally improved metal frames or for certain coatings.

Table 6

Table 6 presents time of day corrections for outdoor conditions. The table works from the assumption that the peak cooling load will occur at 3 p.m. If the load should occur at another time, you have to find the resulting temperature difference. In other words, other tables in *Manual N* are based on the assumption that the peak load occurs at 3 p.m. standard time; therefore, a load that peaks at any other time will be less than the load at 3 p.m. Arriving at an adjusted temperature difference involves multiplying the daily range by the range factor from Table 6 to get the dry bulb correction. Subtract the dry bulb correction from the outside db temperature @ 3p.m. Then, subtract the inside db temperature from the previous figure. This gives you the temperature difference or TD. You will need the TD for other calculations. Don't guess; use Table 6.

HANDOUT #1

The 7-series tables

Tables 7A, 7B, 7C, 7D, 7E, 7F, 7G, 7H, 7I, 7J, 7K, 7L, 7M, 7N, and 7O concern themselves with walls and the variety of materials that walls can be made from. Table 7P concerns prefabricated curtain walls while 7Q is about partitions. Tables 7R and 7S concern themselves with flat roofs, 7T with pitched roofs, 7U with ceiling floor partitions, and 7V with slab floors.

Other tables

Table 8 lists equivalent temperature differences for dark colored walls while Table 9 lists ETDs for dark roofs and Table 9A concerns itself with ETDs across ceiling panels. Ranging from banks to school rooms, Table 10 presents both the sensible and latent heat gains from occupants while Table 11 shows heat gain from electric motors, and Table 11A shows heat gains from lighting. Table 12 continues with heat gain from appliances which includes the computers, terminals, and printers found in modern offices. Tables 13A and 13B concern themselves with building and door infiltration. Table 14 concerns ventilation requirements, and Table 15 lists occupancy estimates that show the square feet of floor space recommended for persons in such places as banks, bowling alleys, and restaurants. Table 16 covers duct heat loss and gain.

Heating information

Heat losses for below grade walls and floors are listed in Table 17, and maximum winter relative humidity is presented in Table 18. Humidification heating loads are presented in Tables 19A, 19B, and 19C for design temperatures of 68°F, 72°F, and 75°F respectively.

System information

Table 20 makes some interesting equipment comparisons that could help avoid problems in equipment selection. Table 21 gives the approximate temperature of unconditioned spaces both winter and summer. Tables 22A and 22B serve as a quick reference to the R-values of common building materials as adapted from the carefully researched materials of the American Society of Heating, Refrigerating, and Air-Conditioning Engineers.

Conclusion

The more than 20 tables in *Manual N* cover hundreds of items and conditions that should be considered in making both cooling and heating load calculations for light commercial applications. Using the tables is not only time saving, it assures the accuracy that is demanded by the modern customer who is looking for cost-efficient equipment and conservation-oriented performance.

LIGHT COMMERCIAL LOAD CALCULATIONS UNIT VI

HANDOUT #2 — CALCULATING PROBLEM LOADS IN LIGHT COMMERCIAL SPACES

Purpose

When a light commercial space houses a variety of activities, the load calculations require special attention. A good example of a space with varied activities is included in ACCA's *Manual N*. A review of the cooling and heating load calculations for the Fox Furniture Store will help an HVAC technician appreciate the challenge of working with light commercial spaces.

Getting started

Place Figure 1 that accompanies this handout alongside this information, and refer to the Form N-1 worksheet that is also included. Notice on Form N-1 that the first item is a listing of all design conditions for the Fox Furniture Store in Meridian, Mississippi. The design conditions dictate all calculations so they need to be correct. In the case of Fox Furniture, we note immediately that the large bank of west-facing plate-glass windows shown in the floor plan will require a time of day correction.

The time of day correction

Cooling loads peak at 3 p.m. The peak load at Fox Furniture is 95°F, so a cooling load that peaks at any other time would be less than 95°F. Since the cooling load at Fox Furniture peaks at 6 p.m., we have to make a time of day correction. Let's do it step by step:

1. Go to Table 6 in *Manual N* and find the correction factor for 6 p.m.
2. Multiply 0.21 by the daily range of 22.
3. $.21 \times 22 = 4.62$ and we round this off to 5 for convenience.
4. Subtract 5 from the outside db @ 3 p.m.
5. $95 - 5 = 90$.
6. Now, subtract the inside db temperature of 75 from 90.
7. $90 - 75 = 15$ which is the TD (temperature difference).

We will use the TD of 15 when working with transmission gains and infiltration, so the time of day correction is important. Although a slight adjustment should also be made for the change from standard to daylight savings time, the adjustment is minimal and should not affect the TD of 15.

HANDOUT #2

Calculating the cooling load

Calculating the cooling load for Fox Furniture should begin with an evaluation of heat gain through all types of glass in the building. This requires reference to Tables 2A, 2B, 3, 4, and 5 in *Manual N*. Walls, doors, partitions, floors—they all become part of calculating the cooling load, and all have *Manual N* Tables to help make the job easier. But look at Item 4 and Form N-1. This guides us through internal heat gain which means heat from equipment such as coffee makers and computers, and heat from people. But heat produced by people depends on how active the people are. We need to know more about the kind of people who will work at Fox Furniture and how many customers will be shopping there.

Working with people

Fox Furniture has an office within a sales area. In other words, we have to plan for a conditioned space within a conditioned space. From design conditions we know there are 4 office employees, 5 sales persons, and an average of 35 customers. Here we have to make some assumptions about how active the people will be. The office personnel will be sitting, doing moderately active work, the sales personnel and customers will be standing, walking, bending, and generally exerting more energy than the office people. From Table 10 in *Manual N* we arrive at factors to help us figure the latent and sensible heat gains for both office workers and sales and customers. When we talk about a conditioned space within a conditioned space, we're often talking about an office adjacent to some other area. Information about occupancy and equipment in both spaces is vital to calculating the cooling load.

Special problems

Fox Furniture has a receiving and shipping storage area with a door large enough to facilitate large pieces of furniture. From design conditions we know that the storage area is not air conditioned in the summer, but it is heated in the winter. This means sizing the heating equipment to offset the infiltration load or installing a door heater that would operate intermittently as needed. In the case of Fox Furniture, the door heater is the best selection. Table 13B in *Manual N* helps us size the door heater properly.

Conclusion

Calculating cooling and heating loads for light commercial spaces that house varied activities is a challenge. Using Form N-1 and the Tables in *Manual N* help make light commercial load calculations easier. The few special problems posed by the Fox Furniture Store provide a good example of how the process is handled, and a student should review the Fox Furniture calculations to gain a better command of the technical elements in load calculations.

HANDOUT #2

Figure 1 Fox Furniture Store

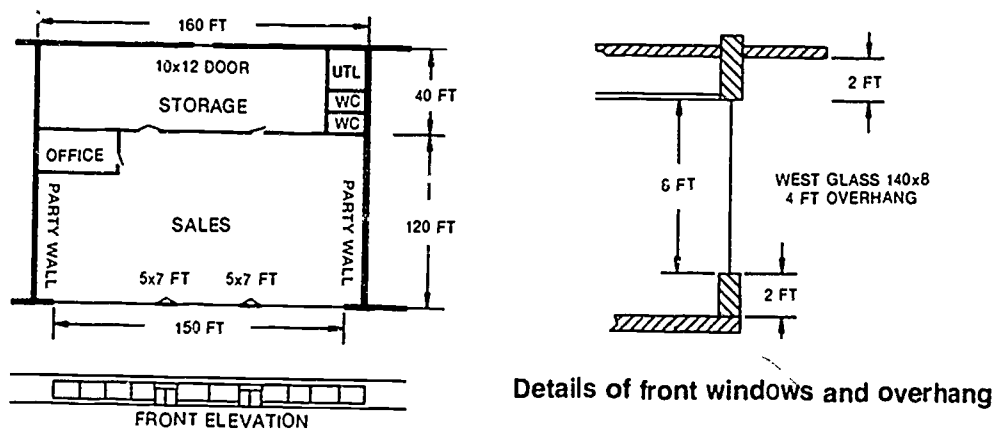

Design Conditions

1. Inside design conditions:
 - a. Winter, sales and office: 70°F, no humidification
 - b. Summer, sales and office: 75°F db and 55% RH
2. Storage area design conditions:
 - a. Heated in winter
 - b. Not air conditioned in summer
3. Peak occupancy
 - a. Sales, 35 customers, 5 sales people
 - b. Office, 4 persons
4. Open hours
 - a. 9 a.m. to 6 p.m.
 - b. Average customer occupancy is 1/2 hour
5. Summer design conditions
 - a. 32 degrees north latitude
 - b. 22 degrees daily range
 - c. 95°F outdoor db @ 3 p.m.
 - d. 76°F outdoor wb
 - e. 33 grains difference @ 55 RH

Courtesy Air Conditioning Contractors of America

HANDOUT #2

For Name	For Furniture		City	MERIDAN	Phone State	MS	Zip	
By Contractor Address			City		Phone State		Zip	

1. DESIGN CONDITIONS (COOLING)							
(Time of Day)	6 PM	(Daily Range)	22	(Latitude)	32		
a) Inside db	75	RH	55%	b) Outside db	95	wb	76
Outside db at 3 pm	95	(-) minus time of day corrections	5	(-) minus inside drybulb	75	=	15
				Grains	33		

2. SOLAR RADIATION HEAT GAIN THROUGH GLASS.					COOLING LOAD	
Exposure	Sq Ft	Solar Factor	Shading and/or Glass Factor		Sensible	Notes
w. DOOR	70	X 134	X 0.94	=	8,817	4 ft overhang
shaded	280	X 31	X 0.94	=	8,159	
glass	840	X 134	X 0.94	=	105,806	
		X	X	=		
		X	X	=		

3. TRANSMISSION GAINS					
	Exposure	Sq. Ft	U Factor	Equivalent or db Temp Diff	
Glass	ALL	1,190	X 1.04	X 15	= 18,564
Walls	West	730	X 0.094	X 26	= 1,784
Doors			X	X	=
Partitions	✓	1,859	X 0.170	X 15	= 4,740
Floors			X	X	=
Roof			X	X	=
Roof/Ceiling			X	X	=
RA Ceiling	✓	12,800	X 0.40	X 4	= 20,480
Use Table 9a to determine the Temperature Difference Across a Return Air Ceiling					

4. INTERNAL HEAT GAIN					Latent
a. Occupants					
Number	Sensible	Latent			
40	X 315		=	12,600	
4	X 255		=	1,820	
40		X 325	=	13,000	
4		X 325	=	1,020	
b. Lights & Others					
NOTE Use 60% of installed watts for lights in return air ceiling		Incandescent Lights	0.60 x 16,000	X 3.4	= 39,360
		Flourescent Lights		X 4.1	=
N P H P	Btuh	Load Factor	Usage Factor		
Motors		X	X		
		X	X		
		X	X		
Appliances	Coffee Maker	2 x 230	Lat 2 x 70	Usage X 1.0	460
Other	Computer	3 x 1300	X	X 1.0	3,900
					Subtotal
					225,690



HANDOUT #2

		Sensible		Latent	
		Page 1 Subtotal		225,690	14,160
5. INFILTRATION					
ft ³ /min	1,444	X db Temp Diff	15	X 11 =	
ft ³ /min	1,444	X Grains Diff	33	X 68 =	
				23,826	32,406
6 SUBTOTAL COOLING LOAD FOR SPACE				249,516	46,563
7. SUPPLY DUCT HEAT GAIN					
Gain factor	0.03	X Line 6 Sensible Gain	249,516	=	7,485
8. ROOM, ZONE OR BLOCK DESIGN LOAD					
Add duct gain (7) to Subtotal (6)				257,001	46,563
Use this load to estimate the cooling CFM					
Cooling CFM = 1.1 x		(Line 8 Sensible)	x	(Supply TD)	=
9. VENTILATION		NOTE For return air ceilings db difference = (outdoor db - plenum db)			
Economizer Leakage	ft ³ /min 615	X db Temp Diff	1.1	X 11 =	10,158
	ft ³ /min 615	X Grains Diff	0.68	X 70 =	13,801
10. RETURN AIR LOAD FROM LIGHTING AND ROOF					
NOTE add 40% of the installed watts for lights recessed in a return air ceiling		Incandescent Lights	0.40 x 16,000	X 3.4 =	10,126,248
		Flourescent Lights		X 4.1 =	
NOTE Use U value & ETD for roof with no ceiling		(Roof Load)	Sq Ft U Factor ETD°		
		12,800 x 0.10 x 5.4			10,69,120
NOTE Subtract the ceiling load refer to No 3		Ceiling Load Credit	(20,480 ceiling load)		-5 degree Correction
11. RETURN DUCT HEAT GAIN					
Gain factor	0	X Line 6 Sensible Gain		=	NA
12. TOTAL LOADS ON EQUIPMENT (Btuh)				342,029	60,364
13. DESIGN CONDITIONS (HEATING)					
Inside db (1 minus Outside db = Difference		70 - 23 = 47			
14. TRANSMISSION LOSSES				HEATING LOAD	
Windows	Exposure ALL	Sq Ft 430	Factor 1.10	db Temp Diff 47	Loss 61,523
Walls	WEST EAST	730 4,130	0.094 0.108	47 47	3225 5,634
Doors	OH	80	0.78	47	2,933
Partitions					
Floors	✓	320	0.21	47	3,158
Roof	✓	12,800	0.10	47	60,160
Roof/Ceiling					
15. INFILTRATION					
ft ³ /min	3,034	X db Temp Diff	47	X 11 =	156,858
16. SUBTOTAL HEATING LOAD FOR SPACE				293,491	
17. SUPPLY DUCT HEAT LOSS					
Loss factor	0.08	X Line 16 Sensible Gain	293,491	=	23,479
18. VENTILATION					
ft ³ /min	615	X db Temp Diff	47	X 11 =	3,796
19. HUMIDIFICATION LOAD					
ft ³ /min		Inside RH (Desired + 100 X Btu/hr	X Max)	=
(water) gal/dav		X (air) ft ³ /min	+ 100 =		NA
20. RETURN DUCT HEAT LOSS					
Loss factor		X Line 16 Loss		=	0
21. TOTAL HEATING LOAD ON EQUIPMENT (Btuh)				349,766	

Courtesy Air Conditioning Contractors of America

**LIGHT COMMERCIAL LOAD CALCULATIONS
UNIT VI****ASSIGNMENT SHEET #1 — CALCULATE HEAT GAIN FOR AN OFFICE SPACE**

Directions: Refer to the floor plan and specifications in Figure 1 that accompanies this assignment sheet. Follow directions carefully as you record heat gain information on the attached Form N-1. Use *Manual N* to reference needed tables and other information. If you do not have a *Manual N*, ask your instructor for guidelines.

1. Refer to Table 1 and enter summer design conditions in block 1 of the N-Form (Form N-1).
2. Refer to Table 6 for outdoor dry bulb time of day correction (if the space is expected to peak around 3 P.M., no correction is necessary).
3. Solar radiation through glass — refer to Table 4 to calculate shaded and unshaded areas of windows and glass doors and enter in block 2.
4. Transmission gains — calculate areas of structure that will experience a transmission gain.
 - a. Look up U values in Tables 5 and 7.
 - b. Look up TD (temperature difference) or ETD (equivalent temperature difference) in Tables 8 and 9.
 - c. Enter information in block 3.
5. Internal Heat gains:
 - a. Refer to Table 10 to determine sensible and latent gain for people and enter in block 4A.
 - b. Refer to Tables 11, 11A, and 12 to determine gains for lights, motors and appliances.
 - c. Enter in block 4-B.
6. Infiltration — refer to Table 13A for estimating infiltration CFM of the building envelope and Table 13B for CFM of door traffic — enter the sum in block 5 and calculate.
7. Subtotal — add the sensible and latent loads, entering each in the proper column of block 6.
8. Duct gain — refer to Table 16 to determine duct gain factor and enter in block 7, multiply the gain factor times line 6 (sensible subtotal) and enter in column for sensible.

ASSIGNMENT SHEET #1

9. Enter room, zone or block design load in block 8 (upper portion); this sensible load should be used to determine CFM that must be delivered to the space; however, the supply CFM cannot be estimated until equipment has been selected.
 10. Ventilation — Use Table 14 (or local codes) to determine CFM needed for ventilation and enter in block 9 information column (fill in TD for sensible load, grains difference for latent), calculate and enter in proper column.
 11. Return air load from lighting and roof — does not apply since the space between the ceiling and roof is not being used as a return air plenum.
 12. Return duct gain — refer to Table 16 for gain factors and enter in information column block 11, multiply times line 6 (sensible gain) and enter in sensible column.
 13. Total loads on equipment — total the sensible and latent columns and enter in the proper column in block 12, this is the load that must be addressed when selecting equipment.
- Have you instructor evaluate your heat gain calculations.

ASSIGNMENT SHEET #1

FIGURE 1 Office Space

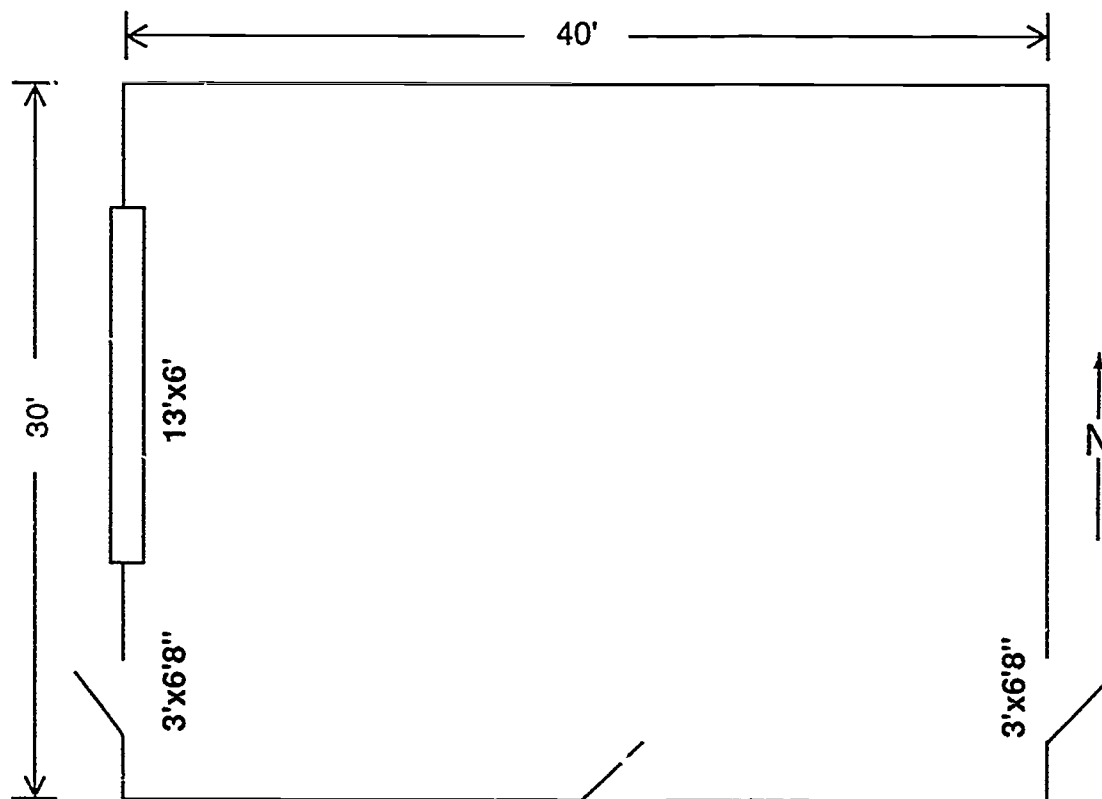

Adjoining space conditioned to same temperature

Specifications

- Location — Jefferson City, Missouri.
- Windows — Clear, 1/4" single pane, unimproved metal frame, top of window 1' below a 4' overhang on the west side.
- Walls — Frame with wood siding, R-11 batt insulation, plywood sheathing and internal finished wall (dark color exterior).
- Doors — Metal with fiberglass core.
- Roof/ceiling — Flat 1" wood deck with 1" insulation above deck, 8 suspended ceiling with R-19 insulation (dark roof).

ASSIGNMENT SHEET #1

Floor — Concrete slab on grade, no insulation.

Lighting — 1,080 watts fluorescent.

Electrical equipment — Five personal computers and printers

Occupancy — Eight people, moderately active, 9 a.m. to 4 p.m.

Air conditioning equipment — Gas heat, electric cooling, package unit, roof mounted, ducted straight down to conditioned space.

NOTE: Adjoining space conditioned to same temperature.

ASSIGNMENT SHEET #1



COMMERCIAL LOAD CALCULATIONS
(ROOM, ZONE or BLOCK LOAD)

Air Conditioning Contractors of America
1513 16th Street, N.W., Washington, D.C. 20036

FORM N - 1

For Name _____	Phone _____
Address _____ City _____	State _____ Zip _____
By Contractor _____	Phone _____
Address _____ City _____	State _____ Zip _____

1. DESIGN CONDITIONS (COOLING)

(Time of Day _____) (Daily Range _____) (Latitude _____)

a) Inside db _____ RH _____ b) Outside db _____ wb _____ Grains _____

Outside db @ 3 p.m. _____ () minus time of day correction _____ () minus inside drybulb _____ = _____ TD

2. SOLAR RADIATION HEAT GAIN THROUGH GLASS.					COOLING LOAD	
Exposure	Sq Ft	Solar Factor	Shading and/or Glass Factor	=	Sensible	Notes
		X	X	=		
		X	X	=		
		X	X	=		
		X	X	=		
		X	X	=		
		X	X	=		
		X	X	=		
		X	X	=		

3. TRANSMISSION GAINS						
	Exposure	Sq Ft	U Factor	Equivalent or Temp Diff	=	
Glass		X	X	=		
		X	X	=		
		X	X	=		
		X	X	=		
Walls		X	X	=		
		X	X	=		
		X	X	=		
Doors		X	X	=		
		X	X	=		
Partitions		X	X	=		
Floors		X	X	=		
Roof		X	X	=		
Roof/Ceiling		X	X	=		
RA Ceiling		X	X	=		

Use Table 9a to determine the Temperature Difference across a Return Air Ceiling

4. INTERNAL HEAT GAIN					Latent
a. Occupants	Number	Sensible	Latent	=	
		X		=	
		X		=	
			X	=	
			X	=	

b. Lights & Others						
		Incandescent Lights	Flourescent Lights	Watts	X 3 4	X 4 1
					=	
					=	
	N P H P	Btuh	Load Factor	Usage Factor		
Motors			X	X		
			X	X		
			X	X		
	Appliances	Sens	Lat	Usage		
				X		
				X		
				X		

*This form designed to be used with ACCA Manual H Page 1 Subtotal

Courtesy Air Conditioning Contractors of America



ASSIGNMENT SHEET #1

				Sensible	Latent
Page 1 Subtotal					
5. INFILTRATION					
ft^3/min	X db Temp Diff	X 11	=		
ft^3/min	X Grains Diff	X 0.68	=		
6. SUBTOTAL COOLING LOAD FOR SPACE					
7. SUPPLY DUCT HEAT GAIN					
Gain factor	X Line 6 Sensible Gain		=		
8. ROOM, ZONE OR BLOCK DESIGN LOAD					
Add duct gain (7) to Subtotal (6) Use this load to estimate the cooling CFM					
Cooling CFM = 1.1 x	(Line 8 Sensible)	x	(Supply TD)	=	
9. VENTILATION					
NOTE For return air ceilings db difference = (ou'door db - plenum db)					
ft^3/min	X db Temp Diff	X 11	=		
ft^3/min	X Grains Diff	X 0.68	=		
10. RETURN AIR LOAD FROM LIGHTING AND ROOF					
NOTE add 40% of the installed watts for lights recessed in a return air ceiling					
	Incandescent Lights	X 3.4	=	(+)	
	Flourescent Lights	X 4.1	=	(+)	
NOTE Use U value & ETD for roof with no ceiling					
	(Roof Load) Sq Ft X U Factor X ETD		=	(+)	
NOTE Subtract the ceiling load, refer to No. 3					
	Ceiling Load Credit		=	(-)	
11. RETURN DUCT HEAT GAIN					
Gain factor	X Line 6 Sensible Gain		=		
12. TOTAL LOADS ON EQUIPMENT (Btuh)					
13. DESIGN CONDITIONS (HEATING)					
Inside db () minus Outside db = Difference					
14. TRANSMISSION LOSSES				HEATING LOAD	
	Exposure	Sq Ft	Factor	db Temp Diff	
Windows		X	X	X	=
		X	X	X	=
		X	X	X	=
Walls		X	X	X	=
		X	X	X	=
		X	X	X	=
Doors		X	X	X	=
		X	X	X	=
Partitions		X	X	X	=
Floors		X	X	X	=
Roof		X	X	X	=
Roof/Ceiling		X	X	X	=
15. INFILTRATION					
ft^3/min	X db Temp Diff	X 11	=		
16. SUBTOTAL HEATING LOAD FOR SPACE					
17. SUPPLY DUCT HEAT LOSS					
Loss factor	X Line 16 Sensible Gain		=		
18. VENTILATION					
ft^3/min	X db Temp Diff	X 11	=		
19. HUMIDIFICATION LOAD					
ft^3/min	Inside RH (Desired	y Max)		
(water gal/day	X (air) ft^3/min	+ 100 X Btu/hr	=		
		+ 100	=		
20. RETURN DUCT HEAT LOSS					
Loss factor	X Line 16 Loss		=		
21. TOTAL HEATING LOAD ON EQUIPMENT (Btuh)					

Courtesy Air Conditioning Contractors of America

LIGHT COMMERCIAL LOAD CALCULATIONS UNIT VI

ASSIGNMENT SHEET #2 — CALCULATE HEAT LOSS FOR AN OFFICE SPACE

Directions: Continue to use *Manual N* as required for reference. Complete heat loss entries on the appropriate forms from Assignment Sheet #1. Be sure to reference the floor plan in Assignment Sheet #1 as needed to complete your heat loss calculations.

1. Enter heating design information in block 13 (see Table 1).
2. Block 14 — calculate the areas of building components that will experience a transmission loss. Enter the "U" value for each component on the form and calculate (see Tables 5 and 7).
 - a. Glass — separate calculations must be made for each type of glass.
 - b. Walls — separate calculations must be made for different types of wall construction (see Table 7) all wall loads are based on net wall area.
 - c. Door — find the door value in Table 7 and calculate loss.
 - d. Partition — may be ignored since the adjoining space is conditioned.
 - e. Roof — find the roof or ceiling factor from Table 7 and calculate loss.
 - f. Floor — find the factor for the floor from Table 7 and calculate loss: Slab floor is calculated per linear foot.
3. Block 15 — Infiltration — Use Table 13a for making estimates of building skin infiltration and Table 13b for infiltration from door traffic, enter the sum and calculate.
 - a. Maintain the space at neutral pressure and refer to Table 13a, air changes per hour and average construction.
 - b. Use the same door traffic as cooling estimate from Table 13b.
(Total infiltration CFM is equal to envelope CFM plus door traffic CFM.)
4. Block 16 — Subtotal the heating load.
5. Block 17 — Supply duct heat loss, refer to table 16 for duct loss multipliers.
6. Block 18 — Ventilation
7. Block 19 — Humidification load — refer to Table 18 to find the maximum allowable relative humidity level. Refer to Table 19 to determine humidifier capacity to maintain the desired RH level. The total amount of outdoor air that must be humidified equals the sum of infiltrated CFM and ventilation CFM. Enter the values and calculate. Do not add the humidification load if the humidifier has its own self-contained source of heat.

ASSIGNMENT SHEET #2

8. Block 20 — Use the return duct multiplier (table 16) and the subtotal heating load (block 16) to calculate return duct loss.
 9. Block 21 — Total heating load is determined by adding the supply duct loss, ventilation load, humidification load and return duct loss to block 16, subtotal.
- Have your instructor evaluate your heat loss calculations.

**LIGHT COMMERCIAL LOAD CALCULATIONS
UNIT VI**

ANSWERS TO ASSIGNMENT SHEETS

Assignment Sheets #1 and #2

FORM N - 1

For: Name _____		Phone _____	
Address _____		State _____ Zip _____	
By: Contractor _____		Phone _____	
Address _____		State _____ Zip _____	

1. DESIGN CONDITIONS (COOLING)			
(Time of Day <u>3:00 PM</u>) (Daily Range <u>M23</u>) (Latitude <u>38</u>)			
a) Inside db <u>75</u>	RH <u>50</u>	b) Outside db <u>95</u>	wb <u>74</u> Grains <u>28</u>
Outside db @ 3 p.m. <u>95</u> () minus time of day corrections <u>0</u> () minus inside drybulb <u>75</u> = <u>20</u> TD			

2. SOLAR RADIATION HEAT GAIN THROUGH GLASS.					COOLING LOAD	
Exposure	Sq Ft	Solar Factor	Shading and/or Glass Factor		Sensible	Notes
WEST	39	X .86	X .7	=	3153	
" (SHADED)	39	X .27	X .94	=	990	
		X	X	=		
		X	X	=		
		X	X	=		
		X	X	=		
		X	X	=		
		X	X	=		

3. TRANSMISSION GAINS						
	Exposure	Sq Ft	U Factor	Equivalent or db Temp Ditt		
Glass	WEST	78	X 1.04	X 20	=	1622
			X	X	=	
			X	X	=	
Walls	NORTH	320	X .077	X 15	=	370
	EAST	220	X .077	X 36	=	610
	SOUTH	142	X .077	X 17	=	186
	WEST	40	X .56	X 20	=	448
Doors			X	X	=	
Partitions			X	X	=	
Floors			X	X	=	
Roof			X	X	=	
Roof/Ceiling		1200	X .04	X 56.5	=	2712
RA Ceiling			X		=	
Use Table 9a to determine the Temperature Difference Across a Return Air Ceiling						

4. INTERNAL HEAT GAIN					Latent
a. Occupants		Number	Sensible	Latent	
		8	X 255	X	2040
		8	X	X 255	2040
			X	X	
			X	X	
b. Lights & Others					
NOTE: Use 60% of installed watts for lights in return air ceiling		Incandescent Lights	Watts	X 3 4	
		Flourescent Lights	2880	X 4 1	11808
	N P H P	Bluh	Load Factor	Usage Factor	
	Motors		X	X	
			X	X	
			X	X	
	Appliances	Sens	Lat	Usage	
			X	X	
	Other	COMPUTERS	1300	X 5	6500
*This form designed to be used with ACCA Manual N					Page 1 Subtotal
					30,439
					2,040

Courtesy Air Conditioning Contractors of America



ANSWERS TO ASSIGNMENT SHEETS

Assignment Sheets #1 and #2

		Sensible	Latent
Page 1 Subtotal		30439	2040
5. INFILTRATION			
$\frac{ft^3/min}{ft^3/min}$ 46	X db Temp Diff 20	X 11 = 1012	876
46	X Grains Diff 28	X 68 =	
6. SUBTOTAL COOLING LOAD FOR SPACE		31451	2916
7. SUPPLY DUCT HEAT GAIN		SHORT DROPS	
Gain factor	X Line 6 Sensible Gain	= -0-	-0-
8. ROOM, ZONE OR BLOCK DESIGN LOAD		31451	2916
Add duct gain (7) to Subtotal (6) Use this load to estimate the cooling CFM			
Cooling CFM = 11 x		(Line 8 Sensible)	(Supply TD)
9. VENTILATION		NOTE For return air ceilings db difference = (outdoor db-plenum db)	
$\frac{ft^3/min}{ft^3/min}$ 80	X db Temp Diff 20	X 11 = 1760	
80	X Grains Diff 28	X 68 =	1523
10. RETURN AIR LOAD FROM LIGHTING AND ROOF			
NOTE add 40% of the installed watts for Lights recessed in a return air Ceiling		Incandescent Lights X34 = (+)	
		Flourescent Lights X41 = (+)	
NOTE Use U value & ETD for roof with no ceiling		(Roof Load) Sq Ft X U Factor X ETD* (+)	N/A
		*ETD correction based on plenum temperature	
NOTE: Subtract the Ceiling load, refer to No 3		Ceiling Load Credit (-)	
11. RETURN DUCT HEAT GAIN		SHORT DROPS	
Gain factor	X Line 6 Sensible Gain	= -0-	-0-
12. TOTAL LOADS ON EQUIPMENT (Btuh)	SENS.	33211	4439
		37,650	
13. DESIGN CONDITIONS (HEATING)			
Inside db () minus Outside db = Difference 70-7=63			
14. TRANSMISSION LOSSES		HEATING LOAD	
Windows	Exposure 78 Sq Ft	Factor 1.10	db Temp Diff 63 = 5403
Walls	682	.077	63 = 3300
Doors	40	.56	63 = 1411
Partitions			
Floors	140	.81	63 = 7144
Roof			
Roof/Ceiling	1200	.04	63 = 3024
15. INFILTRATION			
$\frac{ft^3/min}{ft^3/min}$ 156	X db Temp Diff 63	X 11 = 10811	
16. SUBTOTAL HEATING LOAD FOR SPACE		31,103	
17. SUPPLY DUCT HEAT LOSS		N/A	
Loss factor	X Line 16 Sensible Gain	=	
18. VENTILATION			
$\frac{ft^3/min}{ft^3/min}$ 80	X db Temp Diff 63	X 11 = 5544	
19. HUMIDIFICATION LOAD			
$\frac{ft^3/min}{(water) gal/day}$	Inside RH (Desired + 100 X Btuh/	XMax) =	
	X (air) ft ³ /min + 100 =		
20. RETURN DUCT HEAT LOSS		N/A	
Loss factor	X Line 16 Loss	=	
21. TOTAL HEATING LOAD ON EQUIPMENT (Btuh)		36,647	

LATENT * TOTAL

Courtesy Air Conditioning Contractors of America

LIGHT COMMERCIAL LOAD CALCULATIONS UNIT VI

TEST

Name _____ Score _____

1. Match the terms on the right with their correct definitions.

- | | | | |
|---------|---|----|---------------------------|
| _____a. | The peak load for an entire building if the entire building is considered to be a single zone | 1. | Peak load |
| _____b. | The load imposed on conditioning equipment when all sources of load are taken at the maximum they will occur at the same time | 2. | Block load |
| _____c. | Outside air introduced into the space through the heating or cooling equipment, replacing air that has been exhausted | 3. | Zone |
| _____d. | The maximum load expected at any given hour of the year | 4. | Design load |
| _____e. | The space between the roof and a ceiling being used as a return air plenum so that ductwork is not required for the return | 5. | Make-up air |
| _____f. | Any space in a building that requires its own controls to assure that design conditions will be maintained | 6. | Return air ceiling plenum |

2. Select true statements concerning *Manual N* and light commercial load calculations. Place an "X" beside each true statement.

- _____a. Procedures for light commercial load calculations presented in ACCA's *Manual N* are for heating and cooling in small commercial and public assembly applications.
- _____b. *Manual N* calculations are primarily for summer, winter, and year round conditioning systems using unitary equipment.
- _____c. *Manual N* also applies to large buildings using built-up or central station equipment for air conditioning.
- _____d. Where an application involves life, safety, or processes that depend on maintaining a specific indoor design condition, a consulting engineer should be employed.

TEST

3. Select from the following list load components for heat loss and heat gain in a light commercial space. Place an "X" beside components that apply.
- a. Construction details
 - b. Physical size
 - c. Orientation of the building or space
 - d. Name of building
 - e. Lighting
 - f. Occupancy
 - g. Appliances and equipment
 - h. Street traffic count
 - i. Infiltration
 - j. Ventilation
 - k. Schedule and type of use
 - l. Telephone system
 - m. Inside conditions
 - n. Outside conditions
4. Complete statements concerning other sources of light commercial heat gain. Circle the material that best completes each statement.
- a. The (planned use) (structure) of a light commercial space will automatically mean that there will be other sources of heat gain.
 - b. Heat gain from lighting can be figured two ways.
 - 1) Incandescent lighting can be calculated by multiplying (3.4 Btuhs) (4.1 Btuhs) per watt.
 - 2) Fluorescent lighting can be calculated by multiplying (4.1 Btuhs) (3.4 Btuhs) per watt.

TEST

- c. Heat gain from motors must be handled carefully:
- 1) Special care must be taken to find the (operating amperage) (current draw) of large motors or many small motors that would add heat gain.
 - 2) Since motors do not run continuously, a (stand-by factor) (use factor) has to be applied to heat gain calculations.
- d. Heat producing equipment such as steam tables, ranges, and fryers must be taken into account, and both (sensible and latent) (day and night) loads must be considered.
- e. Take into consideration loads within other loads, conditioned spaces that are part of (attached building) (larger conditioned spaces).
5. Complete statements concerning the winter humidification load. Circle the material that best completes each statement.
- a. The addition of moisture to humidify a space requires the expenditure of (heat) (money) and the winter humidification load must be calculated in a light commercial space.
 - b. Humidification loads are based on the heat required to evaporate a pound of water, and that is approximately (1,070 BTUs) (900 BTUs).
6. Complete statements concerning time of day corrections. Circle the material that best completes each statement.
- a. The time of day that a space cooling load peaks is (not always) (always) apparent.
 - b. When calculating loads that peak at a time other than (3 p.m.) (4 p.m.), a time of day correction must be made for outdoor conditions.
7. List considerations for selecting equipment for a normal cooling applications. Place an "X" beside each items that applies.
- a. The following should match as closely as possible:
 - ___1) Total sensible load
 - ___2) Equipment brand names
 - ___3) Total latent load
 - ___4) Equipment placement
 - ___5) Required air flow in CFM

TEST

- b. The operation in a light commercial space is usually:
- 1) Continuous
 - 2) Intermittent
8. Select true statements concerning U values. Place an "X" beside each true statement.
- a. Since U values are used in calculating both cooling and heating loads, it is essential to know what a U value is and how to put a U value to work.
 - b. A U value is based on the total resistance of a component, and that is all.
 - c. To arrive at the U value, we have to add the outside air film resistance and inside air film resistance to the total wall resistance.
 - d. Once total resistance and outside/inside air film resistance have been added, the U value or transmission coefficient can be found by dividing 1.0 by the net effective resistance.
 - e. The U value or U factor as it is also called is multiplied by the square footage of the component which in turn is multiplied by the dry bulb temperature difference to give the transmission gain in Btuh.
9. Complete statements concerning equivalent temperature difference. Circle the material that best completes each statement.
- a. When the heat gain through a component is calculated, the effects of the sun and (thermal storage) (time) must be taken into effect.
 - b. The sun has the same effect as increasing the temperature difference across a component and the ETD is used to calculate the heat (flow) (loss).
 - c. The ETD depends on orientation of the component, time of day, and construction materials, so the process has been simplified by using (standard) (average) ETDs which eliminate all the paperwork and calculations.
 - d. The ETDs for light commercial structures are grouped by (charts) (letter numbers) and appear in tables in *Manual N*.
- (NOTE: If the following activities have not been accomplished prior to the test, ask you instructor when they should be completed.)
- 10. Calculate the heat gain for an office. (Assignment Sheet #1)
 - 11. Calculate the heat loss for an office. (Assignment Sheet #2)

**LIGHT COMMERCIAL LOAD CALCULATIONS
UNIT VI**

ANSWERS TO TEST

1. a. 2
b. 4
c. 5
d. 1
e. 6
f. 3

2. a, b, d

3. a, b, c, e, f, g, i, j, k, m, n

4. a. Planned uses
b. 1) 3.4 Btuhs
2) 4.1 Btuhs
c. 1) Operating amperage
2) Use factor
d. Sensible and latent
e. Larger conditioned spaces

5. a. Heat
b. 1,070 BTUs

6. a. Not always
b. 3 p.m.

7. a. 1), 3), and 5)
b. 2)

8. a, c, d, e

9. a. Thermal storage
b. Flow
c. Average
d. Letter numbers

10. Evaluated according to answers to assignment sheets

11. Evaluated according to answers to assignment sheets

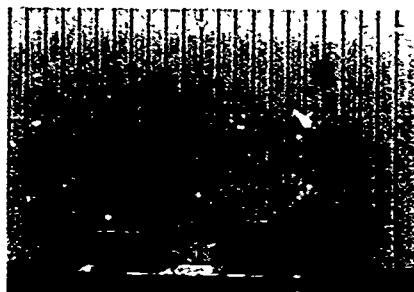

**LIGHT COMMERCIAL
SYSTEM DESIGN
UNIT VII**

UNIT OBJECTIVE

After completion of this unit, the student should be able to solve problems affecting the design of a light commercial HVAC system. The student should also be able to determine the velocity and volume of air flowing in a duct. These competencies will be demonstrated by completing the job sheet and by scoring a minimum of 85 percent on the unit test.

SPECIFIC OBJECTIVES

After completion of this unit, the student should be able to:

1. Match terms related to light commercial system design with their definitions.
2. Select true statements concerning structural and space considerations in system design.
3. Solve problems concerning equipment location in system design.
4. Complete statements concerning control requirements in system design.
5. Solve problems concerning electrical considerations in system design.
6. Solve problems concerning how ceiling design affects system design.
7. Select true statements concerning air distribution and system design.
8. Complete statements concerning noise and system design.
9. Complete statements concerning odor control and system design.
10. Solve problems concerning fire codes and system design.
11. Select true statements concerning filters and system design.
12. Select true statements concerning humidification and system design.
13. Complete statements concerning duct materials and system design.
14. Solve problems concerning the methods of sizing duct.
15. Solve problems concerning twinning furnaces.

OBJECTIVE SHEET

16. Complete statements concerning balancing an air distribution system.
17. Demonstrate the ability to determine velocity and volume of air flowing in a duct. (Job Sheet #1)

**LIGHT COMMERCIAL SYSTEM DESIGN
UNIT VII**

SUGGESTED ACTIVITIES

- A. Obtain additional materials and/or invite resource people to class to supplement/reinforce information provided in this unit of instruction.

(NOTE: This activity should be completed prior to the teaching of this unit.)

- B. Make transparencies from the transparency masters included with this unit.
- C. Provide students with objective sheet.
- D. Discuss unit and specific objectives.
- E. Provide students with information and assignment sheets.
- F. Discuss information sheet.

(NOTE: Use the transparencies as needed to enhance the information.)

- G. Provide students with the job sheet.
- H. Discuss and demonstrate the procedures outlined in the job sheet.
- I. Integrate the following activities throughout the teaching of this unit:
1. Demonstrate to the class the use of a velometer on an operative system.
 2. Arrange a field trip if possible for students to see a light commercial HVAC installation in progress.
 3. Meet individually with students to evaluate their progress through this unit of instruction, and indicate to them possible areas for improvement.
- J. Give test.
- K. Evaluate test.
- L. Reteach if necessary.

REFERENCES USED IN WRITING THIS UNIT

- A. *Equipment Selection and System Design Procedures for Commercial Summer and Winter Air Conditioning (using unitary equipment)*, Manual Q. Washington, DC 20036: Air Conditioning Contractors of America, no date.
- B. "Engineering Report No. 149, Duct System Measurements." Waterville, OH 43801: United McGill Corporation, 1987.

**LIGHT COMMERCIAL SYSTEM DESIGN
UNIT VII**

INFORMATION SHEET

I. Terms and definitions

- A. **Anemometer** — An instrument that measures the actual linear travel, in feet, of an air stream

(NOTE: The instrument was designed originally for meteorological measurements.)

- B. **Concentric diffuser** — A supply outlet and return inlet contained in one assembly, having a common center

- C. **Economizer** — A motorized dampering assembly that allows outdoor cool air to be introduced to the conditioned area through the duct system instead of operating the compressor in the unit

- D. **Enthalpy control** — A control used on some economizers to monitor total heat (latent plus sensible) of the outdoor air, compare it to the average return air total heat, and mix air accordingly

- E. **Hydraulic radius** — The ratio of the cross-sectional area of a duct to its perimeter

(NOTE: Rectangular ducts whose aspect ratio does not exceed 8:1 will have the same static pressure loss for equal lengths and velocities of flow as circular ducts of the same hydraulic radius.)

- F. **Velometer** — An instrument that reads air velocity directly in feet per minute (FPM)

- G. **Furnace "twinning"** — A term referring to the installation of two matched furnaces on a single coil or duct system

- H. **"Twinning kit"** — A control panel used when "twinning" furnaces to operate both blowers simultaneously to avoid "reverse flow" which would occur through one furnace if one blower were not running

- I. **Load bearing** — Structural components other than partitions and panel walls designed to support themselves and any added weight to which a structure is subjected

II. Structural and space consideration in system design

- A. Type and location of equipment should be decided only after careful inspection of plans if it is a new building or of the structure itself if it is an existing building.

INFORMATION SHEET

- B. If roof mounted units are planned, the roof structure should be evaluated to determine if it can carry the additional load.
- C. If air handlers are going to be suspended from ceiling or roof supports, those components should also be evaluated.

III. Equipment location in system design

- A. All equipment should be located so that it is accessible for service.
- B. The appearance of visible roof-mounted equipment and exposed ducts must be evaluated to avoid owner dissatisfaction.
- C. When a blower coil is located indoors, a condensate drain will be required, and a small condensate pump may be required to lift condensate to an approved drain.
- D. Horizontal air handlers should have an auxiliary condensate pan located below the primary condensate pan in the event of an overflow, and the auxiliary pan must have its own drain.
- E. Any special building use should be evaluated for equipment location and selection.
- F. Beware of locations that may expose equipment to a corrosive atmosphere.
Example: Beauty shops, some printing processes, and most chemical processes

IV. Control requirements in system design

- A. The degree of comfort achieved by a system depends largely on the control system.

(NOTE: A control system could be anything from a thermostat to the complete controls for an economizer.)
- B. The need to lower costs by conserving energy makes it important to consider energy saving devices.

Example: An economizer allows cool outside air to be used at lower room temperatures instead of using the unit compressor (see Handout #1).
- C. A customer may want signal lights installed to alert maintenance personnel to such problems as a clogged filter or a system malfunction.

V. Electrical considerations in system design

- A. Especially on new construction, the electrical requirements should be carefully communicated to the architect/engineer to assure that adequate wiring will be incorporated into drawings and specifications.

INFORMATION SHEET

- B. For an existing building, the electrical service to the building and the present electrical load should be surveyed by a qualified electrician.
- C. The local power company may have to join the planning process if changes are required or transformer capacity has to be increased.

VI. How ceiling design affects system design

- A. The type of ceiling in a conditioned space greatly influences design of the air distribution system.
- B. Low ceilings require special attention because draft-free distribution is more difficult to achieve with low ceilings.
- C. Ceilings interrupted by beams and other protrusions may require special considerations in order to provide air flow and avoid drafts.
- D. When the space above a ceiling is used as a return air plenum, the supply duct penetrating the space must be sealed to prevent "short circuiting" of air.

VII. Air distribution and system design

- A. The use, size, and construction type must all be kept in mind when designing an air distribution system.
- B. Location and selection of outlets should be made with consideration for:
 - 1. Interior design of the building
 - 2. Local sources of heat gain or loss
 - 3. Performance and design of air outlets
- C. Location of the return air inlet does not greatly affect room air motion, except in the immediate vicinity of the inlet.
- D. Keep supply outlets away from the inlet to avoid "short circuiting" supply air.
- E. An acceptable method of cooling is to install a combination ceiling supply and return inlet, but large floor to ceiling temperature differentials could be encountered during the heating mode. (Transparency 1)

VIII. Noise and system design

- A. An acceptable level of the air conditioning sound depends more upon its relation to background sound level.

Example: High background noises may make the air conditioning sounds seem loud.

INFORMATION SHEET

- B. It is best to avoid a direct line of sight from the air conditioned space to the blower and motor.

(NOTE: If someone can see a noise source, the sound may be psychologically louder.)

- C. Baffling air with a "sound trap" may be necessary.
- D. Lining metal ducts with acoustical absorption materials will help reduce sound levels.

(NOTE: Duct lining should always be nonflammable.)

- E. It takes a good combination of system design and equipment placement to assure a quiet system and customer satisfaction.

IX. Odor control and system design

- A. Odor problems in a conditioned space can be removed physically or chemically.
- B. Adding outdoor air to dilute indoor odors is the most widely used method in light commercial HVAC.
- C. Particulate matter such as smoke can be removed with an electronic air cleaner.
- D. Activated charcoal filters can also be used to absorb odors.

X. Fire codes and system design

- A. In all cases, the installation of fire safety devices must be in accordance with national fire protection standards, with local codes, and with OSHA (Occupational Safety and Health Administration) regulations.
- B. Smoke detectors and fire dampers are just two devices that can be put to effective use in system design.
- C. Almost all codes require blower shutdown in the event of fire.

XI. Filters and system design

- A. The type of filtering designed into a system will depend on the degree of cleanliness desired.
- B. Air cleaners should be selected on the basis of need, but important characteristics to consider are:
 1. Efficiency
 2. Air flow resistance
 3. Dust holding capacity

INFORMATION SHEET**XII. Humidification and system design**

- A. Human comfort is greatly affected by the relative humidity of a conditioned space, and relative humidity control should be an essential part of system design.
- B. Aside from human comfort, light commercial spaces frequently house manufacturing processes where moisture has to be controlled.
- C. Spaces used for materials storage frequently require careful moisture control.

XIII. Duct materials and system design

- A. When ducts are fabricated from metal, the correct weight or gauge should be selected.
- B. Flexible ducts are often used to connect diffusers and air terminals to the trunk lines of duct systems.
- C. Flexible duct also allows outlets to be shifted around without too much difficulty when there is a change in occupancy needs.
- D. Fibrous glass ducts carrying less than 2 inches water gauge have been widely accepted, but manufacturer's installation procedures should be carefully followed.
- E. Ducts located in non-conditioned spaces must be insulated to minimize heat gain or loss and to avoid external condensation.

(NOTE: Additional materials on duct design are available in publications from SMACNA, The Sheet Metal and Air-Conditioning Association.)

XIV. Methods of sizing duct

- A. There are three common methods for sizing duct:
 - 1. The velocity reduction method
 - 2. The static regain method
 - 3. The equal friction method
- B. The velocity reduction method involves an arbitrary assignment of velocities to main and branch ducts.
- C. The velocity reduction method is quick, but it requires considerable experience on the part of the designer.

INFORMATION SHEET

- D. The principle of the static regain method is to reduce the velocity at each branch or outlet or that the gain in static pressure due to velocity reduction is equal to the friction loss of the next duct section.
- E. The static regain method provides a technique where a theoretically constant static pressure can be maintained for all branches and outlets, but the method requires detailed calculations and can be justified only for large systems.
- F. The principle of the equal friction method is to size the ducts so that pressure loss due to friction (per feet of duct length) is the same throughout the system.
- G. The equal friction method is widely used for small and medium size light commercial duct sizing.
- H. The equal friction method is also used for residential duct design, but light commercial applications can usually operate at higher static pressures and velocities.
- I. Multiple return air inlets are more common for light commercial applications than for residential applications.

XV. Twinning furnaces (Handout #2)

- A. Matched furnaces may be installed on a single coil and duct system. (Transparency 2)
- B. A "twinning kit" should be used for system control, assuring that both furnace blowers will operate simultaneously in both heating and cooling.
- C. "Reverse flow" of air may be encountered if one furnace blower is operating and the other is not.

(NOTE: Be alert for "reverse flow" when servicing "twinned" furnaces.)
- D. Heating may be operated single stage or two stage. (Transparencies 3 and 4)

XVI. Balancing an air distribution system

- A. Checks and adjustments should be made by the contractor to determine proper volume (CFM) delivered by each outlet, prior to turning the system over to the owner.
- B. Large jobs may require the architect or engineer to participate in the air balancing in order to guarantee satisfaction to the owner.

Converter Boxes

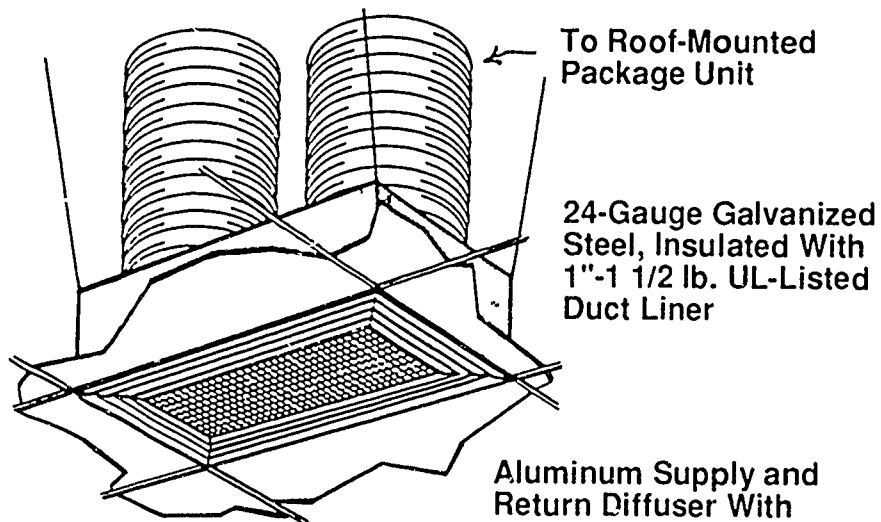

Note:
1. Field Baffles May Be Required for Balancing

Aluminum Supply and Return Diffuser With Curved-Blade Louvers And Eggcrate Return

Supply Air

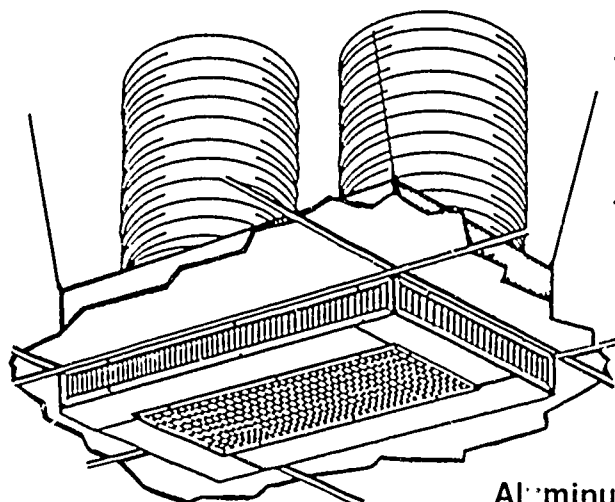
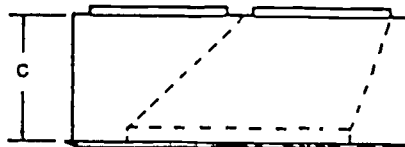

Note:
1. Field Baffles May Be Required for Balancing

Aluminum Double Deflection Grilles Painted Off-White

Supply Air

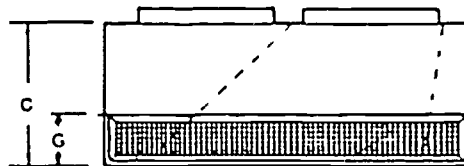

24-Gauge Galvanized Steel, Insulated With 1"-1 1/2 lb. UL-Listed Duct Liner

Courtesy Plenums Incorporated

Twinned Furnaces

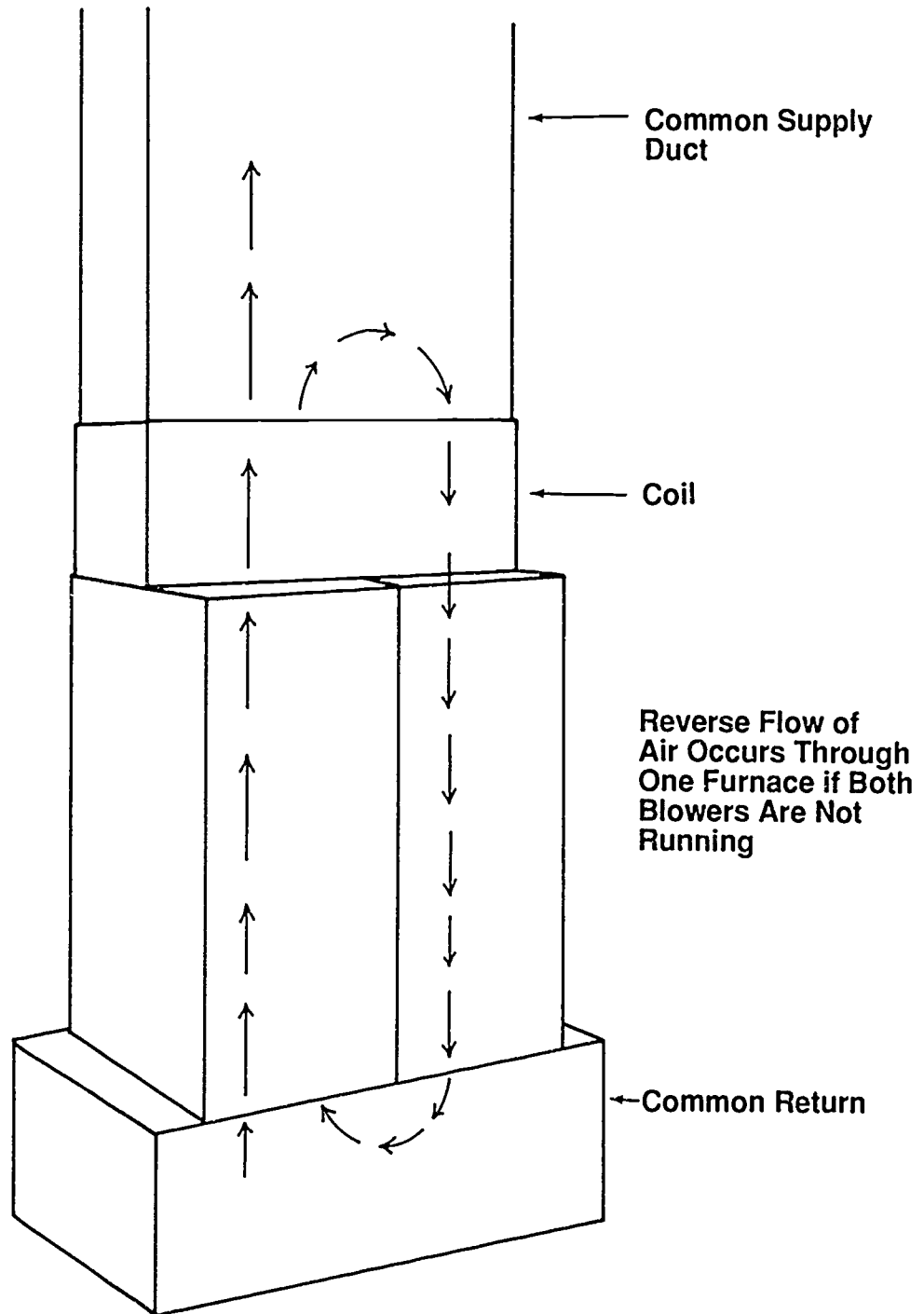

Single-Stage Heating and Single-Stage Cooling (Automatic Changeover)

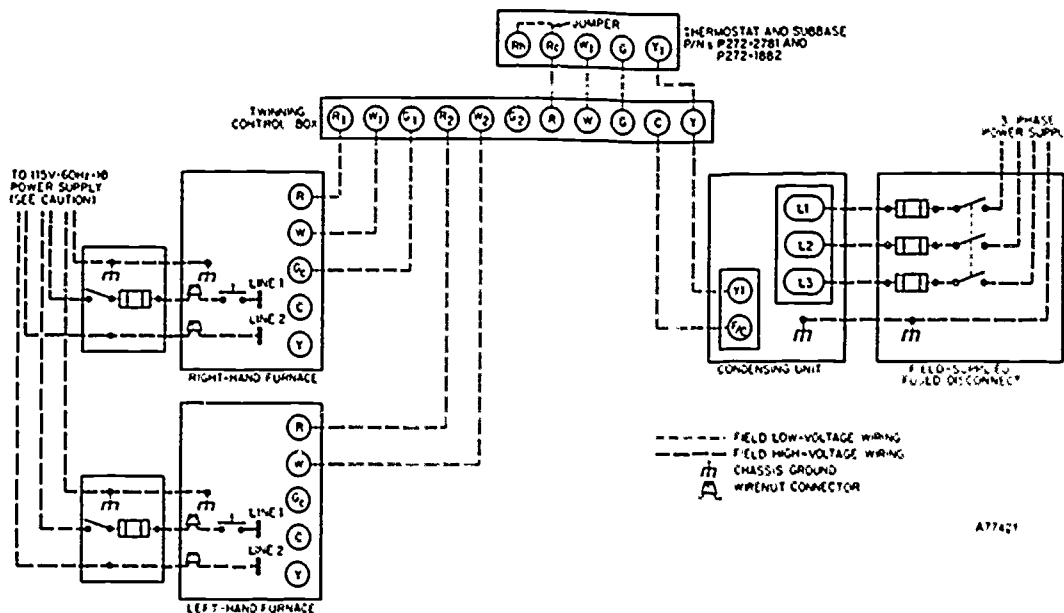

Courtesy Carrier Corporation

Single-Stage Heating and Single-Stage Cooling (Manual Changeover)

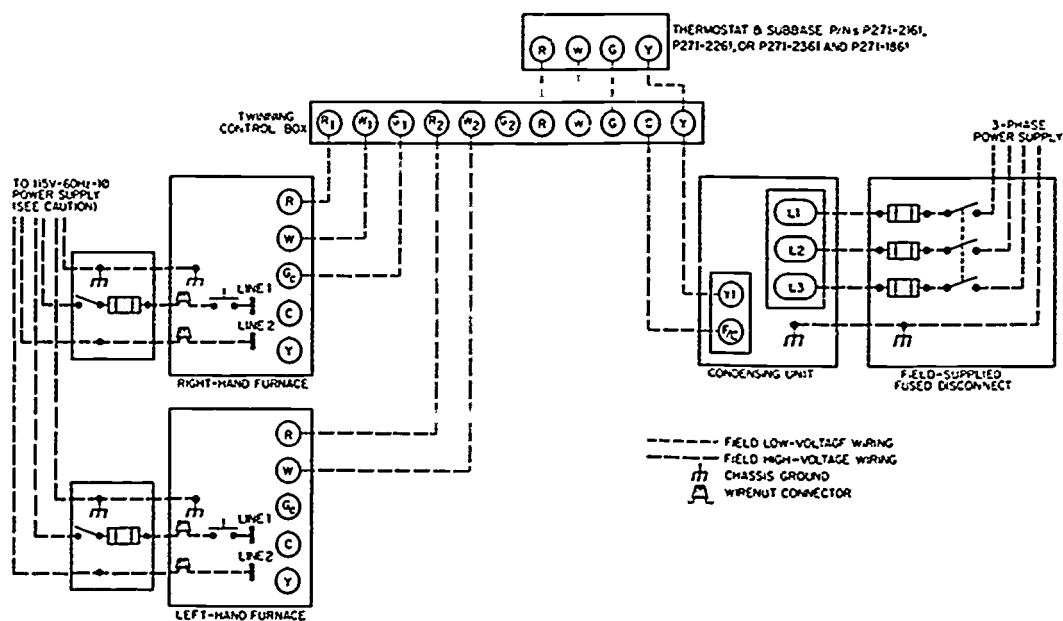

Courtesy Carrier Corporation

LIGHT COMMERCIAL SYSTEM DESIGN UNIT VII

HANDOUT #1 — ECONOMIZERS

Purpose

Enthalpy is the total heat in a volume of air, the latent heat or heat of vaporization plus the sensible heat or temperature. Economizers help reduce cooling expenses in light commercial applications by monitoring and selecting the best source to find air for cooling.

Materials and illustrations in this handout are courtesy of KLO Metal Company of Denison, Texas.

How economizers work

Economizers work with enthalpy control which monitors outdoor air enthalpy and continually compares it to the average of return air enthalpy.

If the outdoor enthalpy is greater, energy consumption is minimized by supplying primarily return air for cooling. (Figure 1)

FIGURE 1

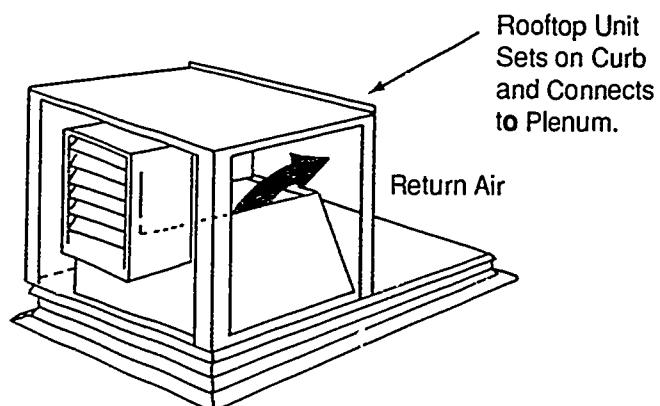

If return air enthalpy is greater, energy consumption is again minimized by supplying primarily outdoor air for cooling. (Figure 2)

FIGURE 2

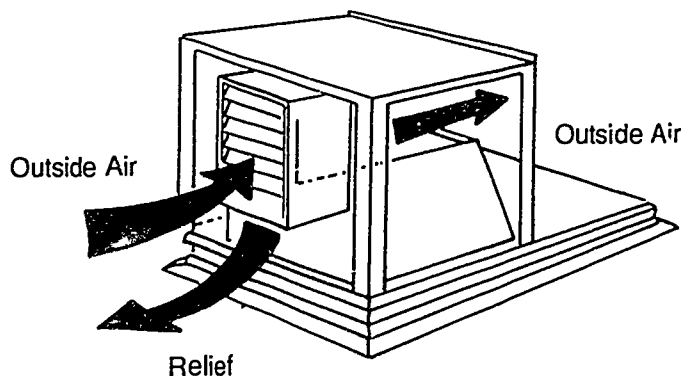

HANDOUT #1

The mixing damper box

For installations that have high internal gains or high solar heat gains, a mixing damper box with proper controls can take advantage of outdoor air to provide almost free cooling when conditions are favorable. Those favorable conditions mean cool days when outdoor air can be drawn into the building to provide free cooling even when internal gains or solar gains are high.

The control system

The control system for a KLO mixing damper box includes a thermostat solid state controller, an enthalpy control, and a 24-volt relay. For applications for the 7½ through 15-ton mixing boxes, the control package also contains a motor. (Figure 3)

FIGURE 3

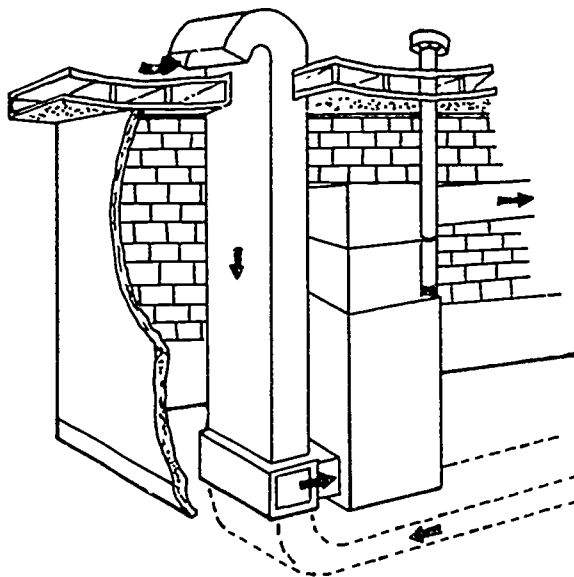

Mixing Damper Box
with UP-FLO Furnace
and Evaporator Coil.

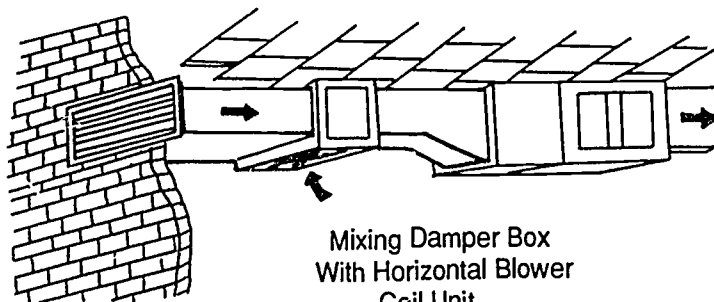

Mixing Damper Box
With Horizontal Blower
Coil Unit.

Conclusion

Linkage adjustments for proper damper control are sometimes required for economizers. And in general, an economizer with proper controls can significantly reduce cooling costs on light commercial applications.

LIGHT COMMERCIAL SYSTEM DESIGN UNIT VII

HANDOUT #2 — TWINNED FURNACES

Purpose

The use of an accessory twinning kit can transform a dual-furnace system into one system using the same duct system. When furnaces are matched with the proper cooling coil and appropriate condensing units, the result is a single-zone heating/cooling system suitable for both large homes and light commercial applications.

Materials and illustrations in this handout are courtesy of the Carrier Corporation.

The twinning kit

Carrier's accessory furnace twinning kit includes the following equipment:

1. All internal control box wiring is complete in the Factory-Wired Control Box which also include the high-voltage wiring.
2. Terminal strips are provided for low-voltage connections from thermostat, furnaces, and twinning control box.
3. Limit control is actually two manual reset limit controls to give added protection against reverse air circulation.
4. The built-in transformer provides the control power to operate the twinning box and the condensing unit if one is used.
5. The single-piece furnace casings are of one-piece construction to limit operating sound. (Figure 1)

FIGURE 1

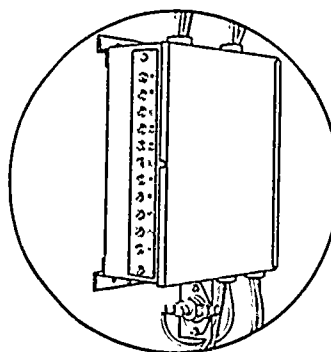
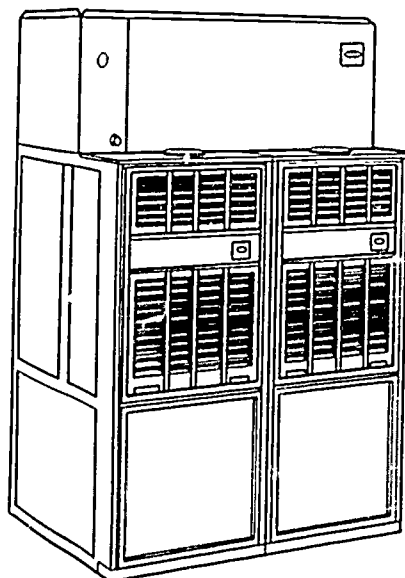

TWINNING KIT

**LIGHT COMMERCIAL SYSTEM DESIGN
UNIT VII**

**JOB SHEET #1 — DETERMINE VELOCITY AND
VOLUME OF AIR FLOWING IN A DUCT**

A. Tools and equipment

1. Forced air system as selected by instructor
2. Drill and bit
3. Velometer
4. Measuring tape
5. Duct tape
6. Pencil and paper
7. Safety glasses

B. Procedure

1. Check for a safe work area and put on safety glasses.
2. Measure the cross-section area of the duct in square feet (144 sq. in. = 1 sq. ft.) and record the measurement here: _____.

(NOTE: Because of the size of duct you will be working with, only 6 interior areas will be measured, but in larger duct, a minimum of 16 areas should be measured. Your instructor may choose to modify this job sheet to reflect the availability of larger duct.)

3. Use your duct measurement to help you imagine that you are dividing a cross-sectional area of the duct into 6 equal areas. (Figure 1)

FIGURE 1

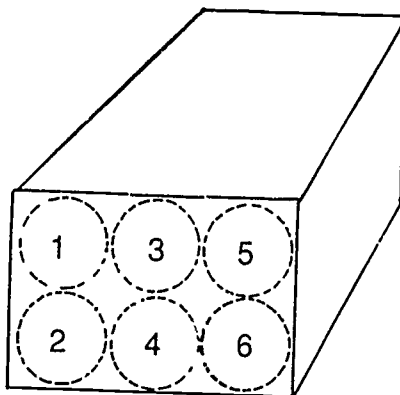

JOB SHEET #1

4. Check the length of the velometer probe and determine how many holes you will have to drill in the duct wall in order to station the probe so that accurate readings can be taken at the points indicated in Figure 1.
5. Drill the number of holes required in the places where the velometer probe can best be inserted.
6. Start the blower fan.
7. Insert the velometer probe so that you can measure the velocity at the center points of the 6 areas established in Step 3.
8. Decide which area will be area #1 and then progress in a given order so that you can properly measure and record the 6 velocities.

Area #1 _____
 #2 _____
 #3 _____
 #4 _____
 #5 _____
 #6 _____

Total: _____

9. Total the 6 readings and then divide by 6 to get the average velocity and record that average here: _____.
10. Turn the blower fan off.
11. Place duct tape over each of the holes you drilled.
12. Calculate the CFM volume flowing in the duct by using the basic flow equation $Q=AV$ where:
 Q = quantity of flow in cubic feet per minute
 V = velocity in feet per minute
 $Q =$ _____ area x _____ velocity
 $Q =$ _____ CFM
- Have your instructor evaluate your calculations.
13. Clean work area and return equipment to proper storage.

**LIGHT COMMERCIAL SYSTEM DESIGN
UNIT VII**

**PRACTICAL TEST #1
JOB SHEET #1 — DETERMINE VELOCITY AND VOLUME OF AIR
FLOWING IN A DUCT**

Student's name _____ Date _____

Evaluator's name _____ Attempt no. _____

Student instructions: When you are ready to perform this task, ask your instructor to observe the procedure and complete this form. All items listed under "Process Evaluation" must receive a "yes" for you to receive an overall performance evaluation.

PROCESS EVALUATION

(EVALUATOR NOTE: Place a check mark in the "Yes" or "No" blanks to designate whether or not the student has satisfactorily achieved each step in this procedure. If the student is unable to achieve this competency, have the student review the materials and try again.)

The student:	YES	NO
1. Secured a safe working environment.	<input type="checkbox"/>	<input type="checkbox"/>
2. Drilled holes enough to accommodate velometer.	<input type="checkbox"/>	<input type="checkbox"/>
3. Measured and recorded velocity at cross-section areas of duct.	<input type="checkbox"/>	<input type="checkbox"/>
4. Calculated average velocity.	<input type="checkbox"/>	<input type="checkbox"/>
5. Patched holes in duct.	<input type="checkbox"/>	<input type="checkbox"/>
6. Calculated CFM using basic flow equation.	<input type="checkbox"/>	<input type="checkbox"/>
7. Secured area and returned materials.	<input type="checkbox"/>	<input type="checkbox"/>

Evaluator's comments: _____

JOB SHEET #1 PRACTICAL TEST

PRODUCT EVALUATION

(EVALUATOR NOTE: Rate the student on the following criteria by circling the appropriate numbers. Each item must be rated at least a "3" for mastery to be demonstrated. (See performance evaluation key below.) If the student is unable to demonstrate mastery, student materials should be reviewed and another test procedure must be submitted for evaluation.)

Criteria:

Workplace preparation	4	3	2	1
Velometer use	4	3	2	1
Velocity Measurements	4	3	2	1
CFM determination	4	3	2	1

EVALUATOR'S COMMENTS: _____

PERFORMANCE EVALUATION KEY

- 4 — **Skilled** — Can perform job with no additional training.
- 3 — **Moderately skilled** — Has performed job during training program; limited additional training may be required.
- 2 — **Limited skill** — Has performed job during training program; additional training is required to develop skill.
- 1 — **Unskilled** — Is familiar with process, but is unable to perform job.

(EVALUATOR NOTE: If an average score is needed to coincide with a competency profile, total the designated points in "Product Evaluation" and divide by the total number of criteria.)

**LIGHT COMMERCIAL SYSTEM DESIGN
UNIT VII**

TEST

Name _____ Score _____

1. Match the terms on the right with their correct definitions.

- | | | | |
|---------|---|----|---------------------|
| _____a. | An instrument that measures the actual linear travel, in feet, of an air stream | 1. | Furnace "twinning" |
| _____b. | A supply outlet and return inlet contained in one assembly, having a common center | 2. | Velometer |
| _____c. | A motorized dampering assembly that allows outdoor cool air to be introduced to the conditioned area through the duct system instead of operating the compressor in the unit | 3. | Enthalpy control |
| _____d. | A control used on some economizers to monitor total heat of the outdoor air, compare it to the average return air total heat, and mix air accordingly | 4. | Anemometer |
| _____e. | The ratio of the cross-sectional area of a duct to its perimeter | 5. | "Twinning kit" |
| _____f. | An instrument that reads air velocity directly in feet per minute | 6. | Concentric diffuser |
| _____g. | The installation of two matched furnaces on a single coil or duct system | 7. | Hydraulic radius |
| _____h. | A control panel used when "twinning" furnaces to operate both blowers simultaneously to avoid "reverse flow" which would occur through one furnace if one blower were not running | 8. | Economizer |
| _____i. | Structural components other than partitions and panel walls designed to support themselves and any added weight to which a structure is subjected | 9. | Load bearing |

TEST

2. Select true statements concerning structural and space considerations in system design. Place an "X" beside each statement that is true.
- ___ a. Type and location of equipment should be decided only after careful inspection of plans if it is a new building or of the structure itself if it is an existing building.
 - ___ b. If roof mounted units are planned, the roof structure should be evaluated to determine its height.
 - ___ c. If air handlers are going to be suspended from ceiling or roof supports, those components should also be evaluated.
3. Solve problems concerning equipment location in system design. Select the best solution to each of the following problems.
- a. You have been directed to plan equipment location for a light commercial application. Your first, best guideline is to ____.
 - 1) Locate all equipment as close to the roof edge as possible.
 - 2) Locate all equipment as close to the center of the roof as possible.
 - 3) Locate all equipment so that it is accessible for service.
 - b. You know a blower coil is going to be located inside. What will be needed in addition to the coil? ____.
 - 1) A control device to turn the coil on and off.
 - 2) A condensate drain and probably a small condensate pump.
 - 3) A large condensate pan with its own drain.
 - c. You know that the conditioned space will often be used for cleaning with chemicals. You should be careful not to ____.
 - 1) Have too much supply air.
 - 2) Place equipment too close to corrosive materials.
 - 3) Choose the wrong equipment.

TEST

4. Complete statements concerning control requirements in system design. Circle the material that best completes each statement.
- The degree of comfort achieved by a system depends largely on the (control system) (relative humidity).
 - The need to lower costs by conserving energy make it important to consider energy saving (devices) (plans).
 - A customer may want signal lights installed to alert maintenance personnel to such problems as a clogged filter or a (system malfunction) (CFM factor).
5. Solve problems concerning electrical considerations in system design. Select the best solution to each of the following problems.
- The concern with new construction is that electrical requirements be ____.
 - Incorporated into drawings and specifications
 - Fully understood by all contractors
 - Clearly outlined in schematics
 - For an existing building, you could survey the present electrical load if you were ____.
 - Employed by the prime contractor
 - A graduate engineer
 - A qualified electrician
 - Transformer capacity has to be increased. This is a job for ____.
 - The design engineer
 - The building owner
 - The local power company
6. Solve problems concerning how ceiling design affects system design. Select the best solution to each of the following problems.
- You know you'll be working with a low ceiling. The problem you anticipate is ____.
 - The need for bigger air handling units
 - Draft-free air distribution
 - Erratic air patterns

TEST

- b. You know a ceiling is interrupted by a beam. The problem you anticipate is ____.
- 1) Difficult to manage heat gain
 - 2) How to provide air flow and avoid drafts
 - 3) Cold spots and hot spots
- c. There is a supply outlet very close to an inlet. The problem you anticipate is ____.
- 1) Air stratification
 - 2) Air motion at the supply
 - 3) A "short circuiting" of supply air

7. Select true statements concerning air distribution and system design. Place an "X" beside each true statement.

(NOTE: For a statement to be true, all parts of the statement must be true.)

- ____a. The use, size, and construction type must all be kept in mind when designing an air distribution system.
- ____b. Location and selection of outlets should be made with consideration of:
- 1) Interior design of the building
 - 2) An excess of windows and glass surfaces
 - 3) Performance and design of air outlets
- ____c. Location of the return air inlet greatly affects room air motion.
- ____d. Keep supply outlets away from the inlet to avoid "short circuiting" supply air.
- ____e. An acceptable method of cooling is to install a combination ceiling supply and return inlet, but large floor to ceiling temperature differentials could be encountered during the heating mode.
8. Complete statements concerning noise and system design. Circle the material that best completes each statement.
- a. An acceptable level of the air conditioning sound depends more upon its relation to (background sound level) (equipment size).
 - b. It is best to avoid a direct line of sight from (outside) (the air conditioned space) to the blower and motor.

TEST

- c. (Baffling) (Stopping) air with a "sound trap" may be necessary.
 - d. Lining metal ducts with (rubberized undercoating) (acoustical absorption materials) will help reduce sound levels.
 - e. It takes a good combination of system design and equipment placement to assure a (quiet) (powerful) system and customer satisfaction.
9. Complete statements concerning odor control and system design. Circle the material that best completes each statement.
- a. Odor problems in a conditioned space can be removed physically or (chemically) (mechanically).
 - b. Adding (outdoor air) (deodorizer) to dilute indoor odors is the most widely used method in light commercial HVAC.
 - c. Particulate matter such as smoke can be removed with (an electronic air cleaner) (a back-up fan system).
 - d. Activated charcoal filters can also be used to (absorb) (repel) odors.
10. Solve problems concerning fire codes and system design. Select the best solution to each of the following problems.
- a. You know your installation meets national fire protection standards but you should also be concerned with _____.
 - 1) Standards for similar installations
 - 2) Prevailing winds in the area
 - 3) Local codes and OSHA
 - b. You know fire dampers will help promote fire safety, but you can also economically use _____.
 - 1) A standard fire alarm system
 - 2) Heat sensing thermocouples
 - 3) Smoke detectors
 - c. One element that most local codes require is _____.
 - 1) Blowers not discharge into prevailing winds
 - 2) Blower shutdown in the event of fire
 - 3) Blowers for heating and cooling be the same

TEST

11. Select true statements concerning filters and system design. Place an "X" beside each true statement.

(NOTE: For a statement to be true, all parts of the statement must be true.)

- ___ a. The type of filtering designed into a system will depend on the degree of cleanliness desired.
- ___ b. Air cleaners should be selected on the basis of need, but important characteristics to consider are:
- 1) Efficiency
 - 2) Air flow resistance
 - 3) Dust holding capacity

12. Select true statements concerning humidification and system design. Place an "X" beside each true statement.

- ___ a. Human comfort is greatly affected by the relative humidity of a conditioned space, and relative humidity control should be an essential part of system design.
- ___ b. Aside from human comfort, light commercial spaces frequently house manufacturing processes where moisture has to be controlled.
- ___ c. Spaces used for materials storage seldom require careful moisture control.

13. Complete statements concerning duct materials and system design. Circle the material that best completes each statement.

- a. When ducts are fabricated from metal, the correct (weight) (thickness) or gauge should be selected.
- b. Flexible ducts are often used to connect diffusers and air terminals to the (trunk lines) (outside air supply) of duct systems.
- c. Flexible duct also allows outlets to be shifted around without too much difficulty when there is a (change in occupancy needs) (design improvement).
- d. Fibrous (glass) (plastic) ducts carrying less than 2 inches water gauge have been widely accepted, but manufacturer's installation procedures should be carefully followed.
- e. Ducts located in non-conditioned spaces must be (painted) (insulated) to minimize heat gain or loss and to avoid external condensation.

TEST

14. Solve problems concerning methods of sizing duct. Select the best solution to each of the following problems.
- a. The velocity reduction method of sizing ducts is quick, but would you use it if you were inexperienced with the process? ____.
 - 1) Maybe
 - 2) Definitely
 - 3) No
 - b. If you were sizing duct for a large system, you would probably choose which sizing method? ____.
 - 1) The velocity reduction method
 - 2) The static regain method
 - 3) The equal friction method
 - c. Someone asks you about the principle of the equal friction method, so you would tell them that it is to size the ducts so that ____.
 - 1) Pressure loss decreases at the extremities of the system
 - 2) Pressure loss due to friction is the same throughout the system
 - 3) Pressure compensates pressure
15. Solve problems concerning twinning furnaces. Select the best solution to each of the following problems.
- a. You know that twinning furnaces on a system would save energy, but the system has a single coil and duct system. What do you recommend? ____.
 - 1) Do not attempt twinning
 - 2) Go right ahead because it will work okay
 - 3) Redesign the system with two coils
 - b. A twinning kit accomplishes an important objective when twinning furnaces, and that is to ____.
 - 1) Control the operation remotely
 - 2) Make the system quieter
 - 3) Assure that both furnace blowers will operate simultaneously for both heating and cooling

TEST

16. Complete statements concerning balancing an air distribution system. Circle the material that best completes each statement.
- a. Checks and adjustments should be made by the contractor to determine proper volume (CFM) delivered by each outlet (prior to) (after) turning the system over to the owner.
 - b. Large jobs may require the (architect or engineer) (owner) to participate in the air balance in order to guarantee satisfaction to the owner.

(NOTE: If the following activity has not been completed prior to the test, ask you instructor when it should be completed.)

17. Demonstrate the ability to determine velocity and volume of air flowing in a duct. (Job Sheet #1)

**LIGHT COMMERCIAL SYSTEM DESIGN
UNIT VII****ANSWERS TO TEST**

1.
 - a. 4
 - b. 6
 - c. 8
 - d. 3
 - e. 7
 - f. 2
 - g. 1
 - h. 5
 - i. 9

2. a, c

3.
 - a. 3)
 - b. 2)
 - c. 2)

4.
 - a. Central system
 - b. Devices
 - c. System malfunction

5.
 - a. 1)
 - b. 3)
 - c. 3)

6.
 - a. 2)
 - b. 2)
 - c. 3)

7. a, d, e

8.
 - a. Background sound level
 - b. The air conditioned space
 - c. Baffling
 - d. Acoustical absorption material
 - e. Quiet

9.
 - a. Chemically
 - b. Outdoor air
 - c. An electric air cleaner
 - d. Absorb

ANSWERS TO TEST

10. a. 3)
b. 3)
c. 2)
11. a, b
12. a, b
13. a. Weight
b. Trunk lines
c. Change in occupancy needs
d. Glass
e. Insulated
14. a. 3)
b. 2)
c. 2)
15. a. 2)
b. 3)
16. a. Prior to
b. Architect or engineer
17. Evaluated according to criteria in Practical Test #1



LIGHT COMMERCIAL AIR TREATMENT UNIT VIII

UNIT OBJECTIVE

After completion of this unit, the student should be able to evaluate devices used in light commercial air treatment and determine air cleaner requirements for an office. These competencies will be demonstrated by completing the assignment sheet and by scoring a minimum of 85 percent on the unit test.

SPECIFIC OBJECTIVES

After completion of this unit, the student should be able to:

1. Match terms related to light commercial air treatment with their definitions.
2. Complete statements concerning comfort level in a light commercial structure.
3. Select true statements concerning air cleaners and existing light commercial structures.
4. Complete statements concerning common electronic air cleaning devices for light commercial applications.
5. Complete statements concerning performance factors for air cleaner applications.
6. Identify basic air patterns for air cleaners.
7. Select true statements concerning capacity sizing.
8. Complete statements concerning mechanical filters.
9. Solve problems concerning humidification for light commercial applications.
10. Complete statements concerning air-to-air exchangers for light commercial structures.
11. Determine the number of electronic air cleaners needed for an office. (Assignment Sheet #1)

LIGHT COMMERCIAL AIR TREATMENT UNIT VIII

SUGGESTED ACTIVITIES

- A. Obtain additional materials and/or invite resource people to class to supplement/reinforce information provided in this unit of instruction.

(NOTE: This activity should be completed prior to the teaching of this unit.)

- B. Make transparencies from the transparency masters included with this unit.
- C. Provide students with objective sheet.
- D. Discuss unit and specific objectives.
- E. Provide students with information and assignment sheets.
- F. Discuss information and assignment sheets.

(NOTE: Use the transparencies as needed to enhance the information.)

- G. Integrate the following activities throughout the teaching of this unit:
1. Arrange for demonstration of a portable electronic air cleaner, if possible.
 2. Demonstrate to the class how to determine the number of electronic air cleaners needed for an office.
 3. Meet individually with students to evaluate their progress through this unit of instruction, and indicate to them possible areas for improvement.
- H. Give test.
- I. Evaluate test.
- J. Reteach if necessary.

REFERENCES USED IN WRITING THIS UNIT

- A. Althouse, Andrew D., and Carl Turnquist and Alfred Bracciano. *Modern Refrigeration and Air Conditioning*. South Holland IL: The Goodheart-Willcox Company, Inc., 1988.
- B. *Refrigeration and Air Conditioning, Second Edition*. Englewood Cliffs, NJ: Air Conditioning and Refrigeration Institute/Prentice-Hall, Inc., 1987.
- C. *Smokeeater Engineering Catalog*. Cincinnati, OH: United Air Specialists, 1989.
- D. *Engineering Catalog*. Louisville, KY: American Air Filter, 1988.

**LIGHT COMMERCIAL AIR TREATMENT
UNIT VIII**

INFORMATION SHEET

I. Terms and definitions

- A. **Capture** — The catching of airborne contaminants so they can be eliminated
- B. **Collection** — Removal of contaminants from an airstream

(NOTE: Capture and collection are not the same, and both must be accomplished to solve an air cleaning problem.)
- C. **Efficiency** — Relative ability of an air cleaner to collect a given contaminant, usually expressed as a percentage
- D. **Local ventilation** — Capturing a contaminant at its source and exhausting it outdoors
- E. **Source capture** — Direct pick up of an airborne contaminant at the source, and the use of ductwork to convey contaminated air to a cleaner
- F. **Unducted** — A self contained air cleaner having its own blower, cleaning and recirculating room air without the use of hoods, ducts, pickups, or enclosures
- G. **Automatic mechanical filter** — Filtering device that replenishes the filter media automatically
- H. **Ozone** — A pungent, colorless gas; an unstable form of oxygen emitted in small amounts by an electronic air cleaner
- I. **Steam-type humidifier** — A humidifier using an electric element to vaporize the water
- J. **Air-to-air exchanger** — Device for exhausting stale air, bringing in fresh air, and recovering some of the heating or cooling that normally would be lost in the process

II. Comfort level in a light commercial structure

- A. A clean, comfortable atmosphere for workers could mean less absenteeism and greater productivity.
- B. A more pleasant, comfortable place to conduct business with customers, could increase business.
- C. Some items must be kept at specific levels of humidity, temperature, and free from contaminants.

INFORMATION SHEET**III. Air cleaners and existing light commercial structures**

- A. Air cleaners usually cannot be effectively added to existing light commercial structures.
- B. Most air handling systems do not circulate air fast enough to maintain an acceptable level of cleanliness.
- C. In structures where significant smoke is generated, the smoke will build up faster than the air cleaner can handle it.
- D. Most HVAC systems cycle, but air cleaning equipment should operate continuously.
- E. An air cleaner removes particulate matter and some odors, but it is not a total air processing system because it does not remove carbon dioxide and does not replenish oxygen.
- F. An air cleaner may actually reduce the fresh air requirement, and fresh-air make-up should be a careful consideration in system design.

IV. Common electronic air cleaning devices for light commercial applications

- A. A source capture system picks up airborne contaminants at their source and uses ductwork to convey the contaminants to an air cleaner.
- B. Source capture systems work well with airborne contaminants produced by such contaminant sources as painting, grinding, woodworking, and welding. (Transparency 1)
- C. Because a source capture system must be close to the source of the contaminant, it requires four essential parts:
 - 1. A source capture device usually a hood
 - 2. Ductwork
 - 3. An inlet diffuser plenum
 - 4. An air cleaner
- D. A totally enclosed air cleaner "boxes in" the contaminant source so that it can escape only through a duct leading to a cleaner.
- E. A hooded application allows contaminants to escape to ambient air at the source, but captures the contaminants before they drift away, and ducts them to a cleaner.
- F. Unducted cleaners are self-contained units with their own blowers, but they do not use pickups, hoods, enclosures, or ductwork.

INFORMATION SHEET

- G. Unducted cleaners recirculate room air, and because they are frequently ceiling or wall mounted, placement is important.

V. Performance factors for air cleaner applications

- A. Efficiency should be a major consideration in air cleaner selection, and efficiency should be determined by a reliable method.
- B. Required air changes per hour should be calculated according to the load of the conditioned space. (Refer to Table 1)

Table 1

LOAD	APPLICATION	AIR CHANGES PER HOUR
Light	Offices Restaurants	4
Average	Bingo halls Lounges	6
Heavy	Autobody Welding	8-10

- C. Air cleaner capacity needs to deliver the proper CFM, and the capacity rating is based on the amount of air the blower can deliver inside the cabinet.
- D. Air cleaners must be sized and placed to create air patterns which will maximize their performance.

VI. Basic air pattern for air cleaners

- A. A peripheral air pattern is one that creates air flow around the room above people and objects. (Figure 1)
- B. To create a peripheral air pattern, a unit is mounted on a ceiling or on a high sidewall. (Figure 1)

INFORMATION SHEET

FIGURE 1

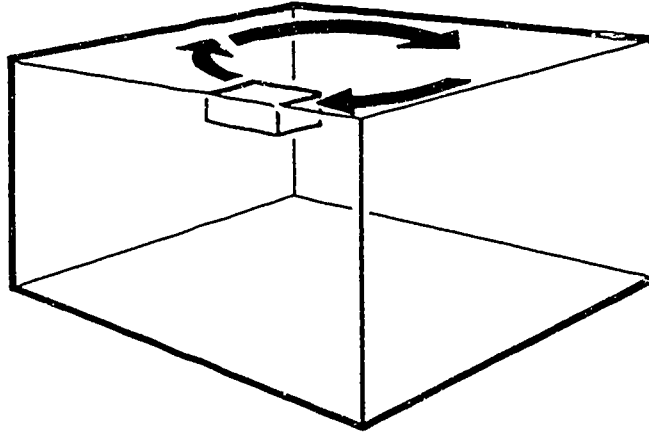

Peripheral air pattern

Courtesy United Air Specialists, Cincinnati, Ohio

- C. A ceiling air sweep air pattern keeps the air moving at ceiling level. (Figure 2)
- D. Ceiling air sweep units are usually mounted in the ceiling with intake and supply grilles flush with the surface. (Figure 2)

FIGURE 2

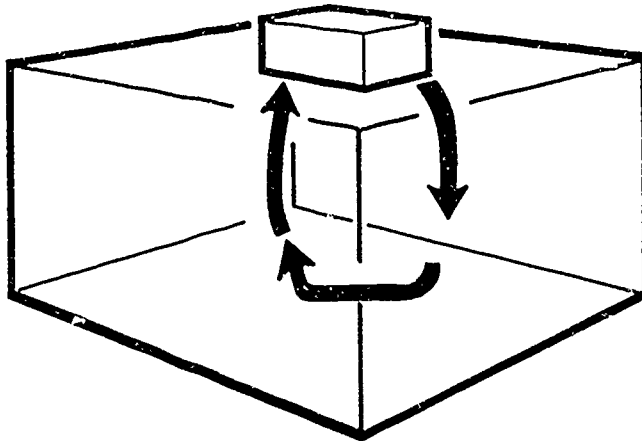

Ceiling air sweep pattern

Courtesy United Air Specialists, Cincinnati, Ohio

INFORMATION SHEET

VII. Capacity sizing

- A. Sizing means knowing both the physical size of a structure and the load and air changes the load will require.
- B. Sizing should include measuring the space and determining the cubic footage.
- C. Sizing should include a careful evaluation of the load, taking into account the "smoker factor."
- D. Sizing must include a determination of the per hour requirements for air changes, and an air change table should always be referenced.

VII. Mechanical filters

- A. Mechanical commonly refers to how a filter is replaced.
- B. Many filters are throwaway types which need replacement as service demands.
- C. Permanent mechanical filters usually have to be washed/cleaned at intervals.
- D. Automatic filters are replaced by filter material from a roll that is advanced across the filter face with a motor-driven gear assembly. (Transparency 2)

IX. Humidification for light commercial applications

- A. Relative humidity needs depend on the use of the conditioned space.
- B. Structural elements may greatly affect relative humidity needs.
- C. A steam-type humidifier may be required to maintain a proper humidity level. (Transparency 3)
- D. Improper humidification can cause discomfort to the occupants of a structure, and excess humidification can contribute to concealed condensation and serious structural damage.

X. Air-to-air exchangers for light commercial applications (Handout #1)

- A. Air-to-air exchangers are popular in light commercial applications because they serve the dual purpose of providing fresh air and conserving energy.
- B. One advantage of an air-to-air exchanger is its ability to replace stale air with fresh air without losing all the heated air or cooled air from inside.
- C. Another advantage of an air-to-air exchanger is that it may be used to pick up contaminants in the area where they are generated and exhaust them along with stale air.

Source Capture System for Welding Stations

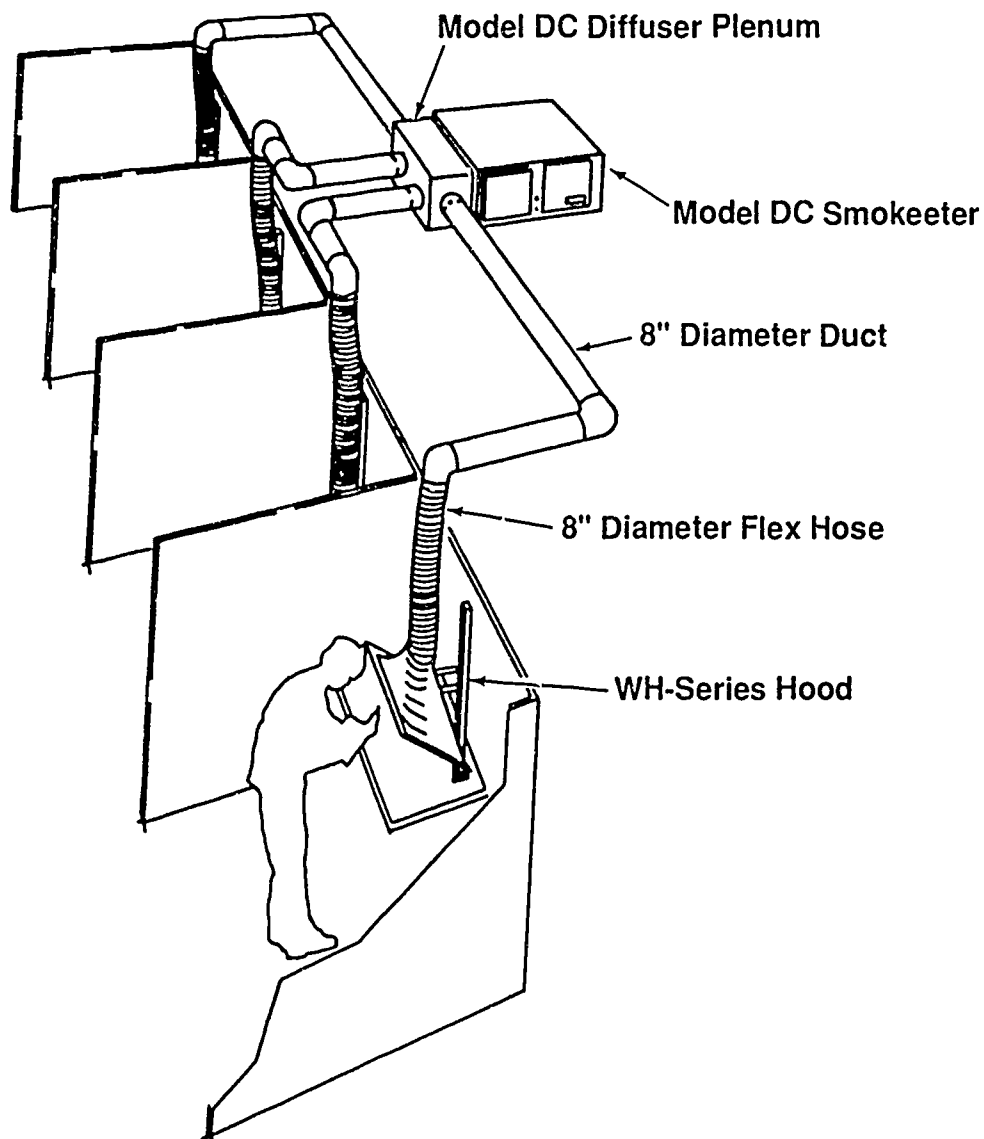

Up to five welding booths using 8" duct. Length of each should be equal for even distribution, or balancing dampers would be required.

Courtesy United Air Specialists

Automatic Feed Mechanical Filter

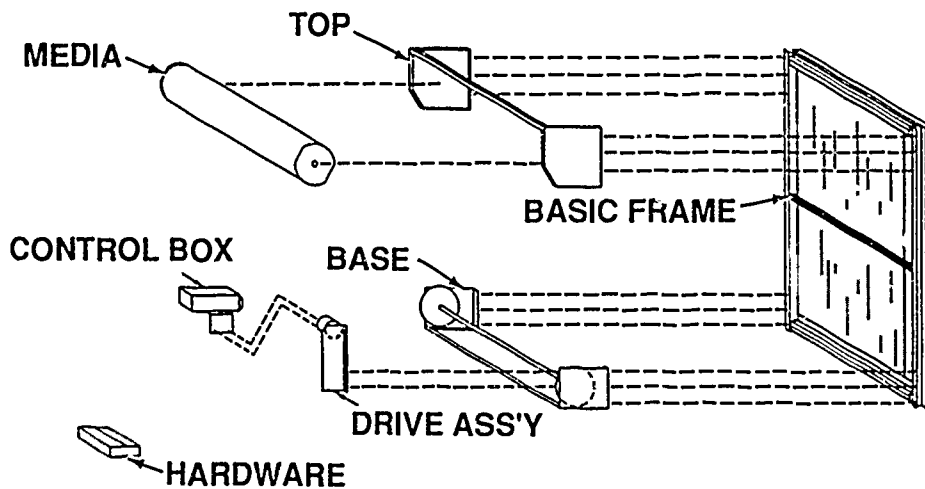
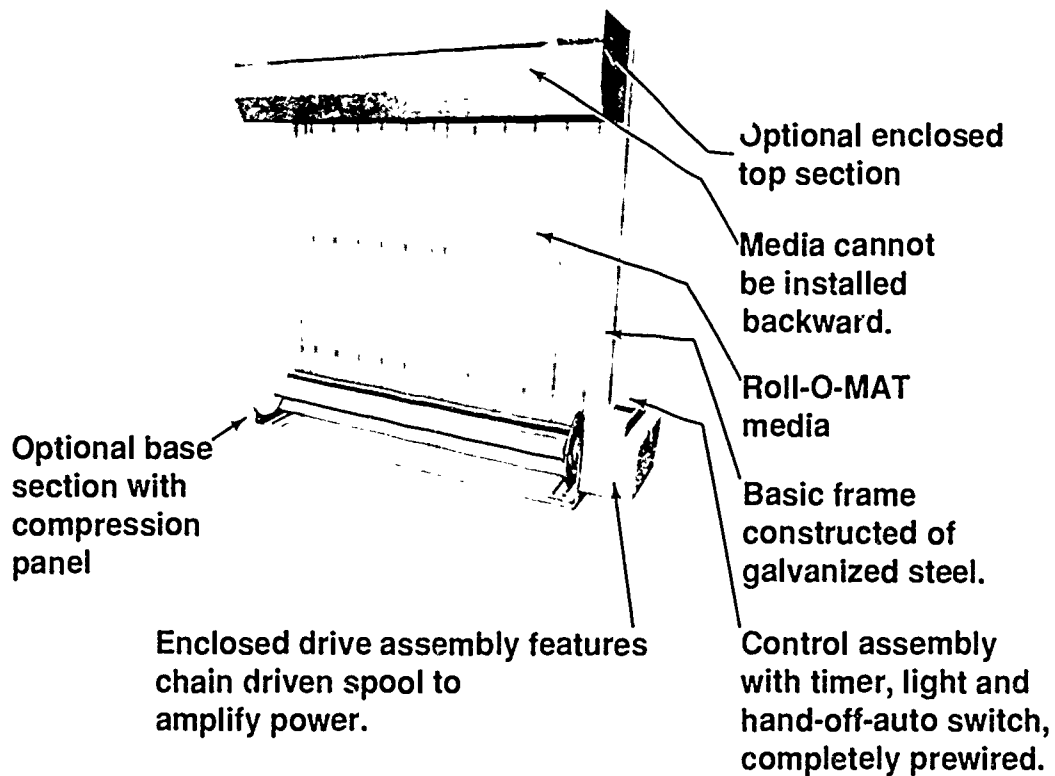

Courtesy American Air Filter

Steam-Type Humidifier

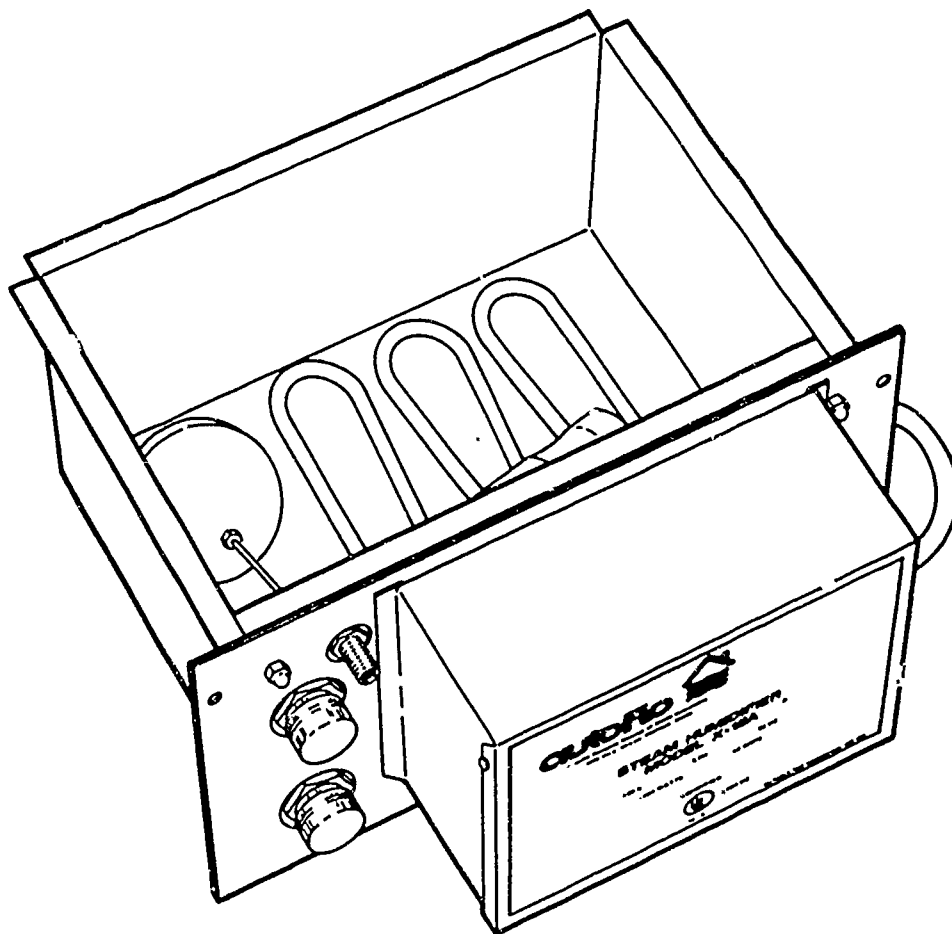

1. Stainless steel reservoir mounts in return or supply duct.
2. Automatically controls the furnace blower for distribution of moisture.
3. Saves energy by keeping the furnace blower running until water in the reservoir has cooled.

Courtesy American Metal Products Co.

LIGHT COMMERCIAL AIR TREATMENT UNIT VIII

HANDOUT #1 — AIR-TO-AIR HEAT EXCHANGERS

Purpose

Because air-to-air exchangers manage to replace stale air with fresh air and conserve energy in the process, they promise to grow in popularity for light commercial applications. A look at an air-to-air exchange system will help a student better appreciate what an air-to-air exchanger does and how it does it.

Dual unit installation

An air-to-air exchanger in a dual unit installation as illustrated in Figure 1 on the next page will help demonstrate how an effective air-to-air installation should be planned. Place Figure 1 alongside this material, and reference the medical offices shown as we talk about the installation.

Installation

To provide essential fresh air and provide desirable energy recovery for two offices, two air-to-air exchangers are mounted above a dropped ceiling which is a conditioned space. Stale air is removed from the examination and waiting rooms and ducted to a plenum box which is also mounted in the dropped ceiling.

Stale air management

Both air-to-air exchangers draw stale air into their stale air intakes through what are called "transition adapters." The stale, contaminated air is then vented outside through two wall caps installed in the building's eaves.

Fresh air management

Fresh air is brought from the outside through the two roof caps. Fresh air is conditioned in the heat exchangers and then distributed to ceiling registers placed at opposite ends of the building's main hallway.

Conclusion

To make the dual unit installation more of an energy saver, all ducting must be insulated duct complete with vapor barrier. When properly planned and installed, an air-to-air exchanger will provide maximum performance and conserve energy in the process.

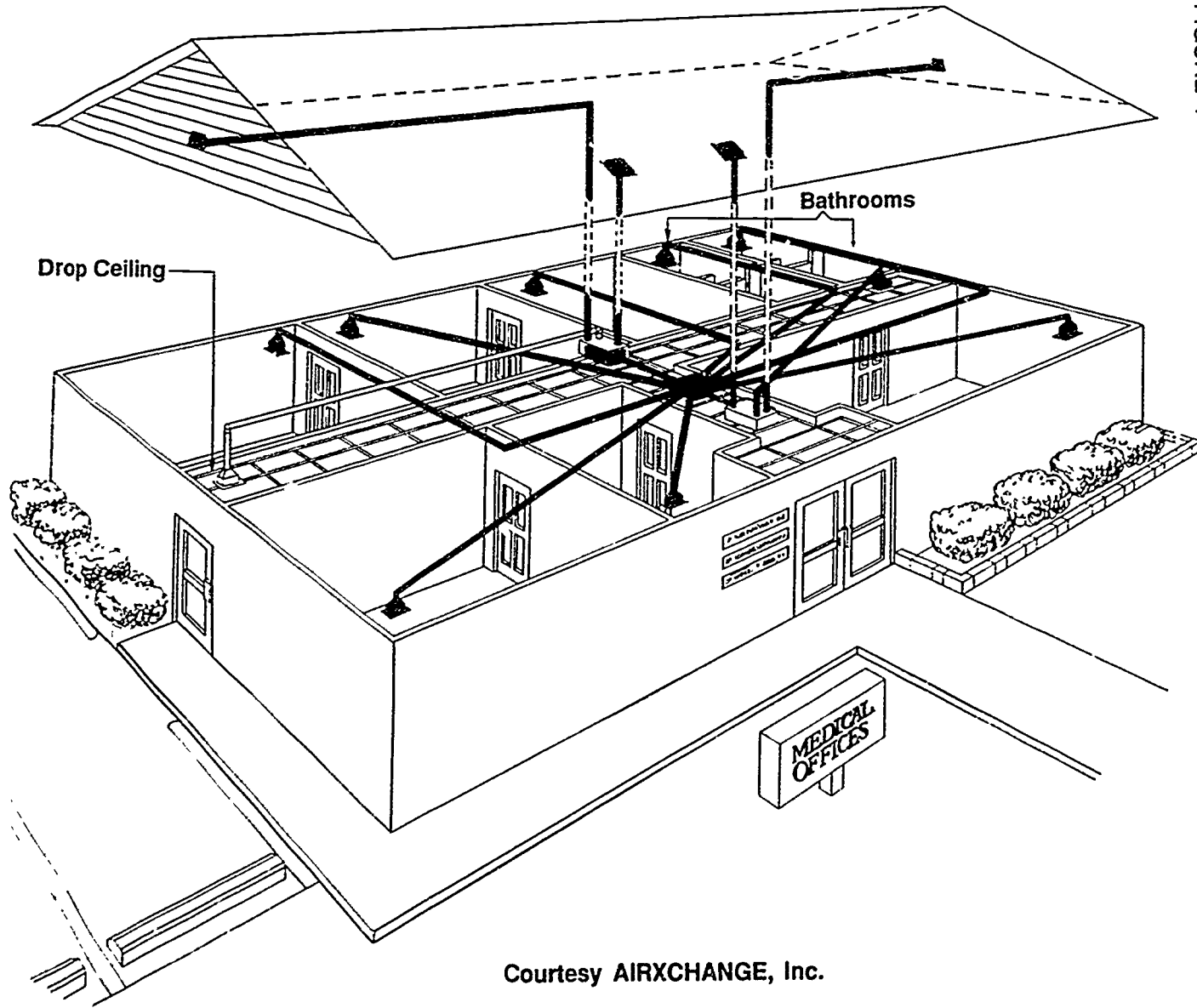

FIGURE 1

LIGHT COMMERCIAL AIR TREATMENT
UNIT VIII

HANDOUT #1

Courtesy AIRXCHANGE, Inc.

**LIGHT COMMERCIAL AIR TREATMENT
UNIT VIII**

**ASSIGNMENT SHEET #1 — DETERMINE THE NUMBER OF ELECTRONIC AIR
CLEANERS NEEDED FOR AN OFFICE**

Directions: In determining the number of air cleaners needed for a given office, use the method indicated here unless the manufacturer of the cleaners you are working with recommends a different procedure. In this case, the vital specifications you need to get started are that the office is 30 feet wide, 40 feet long, and has a 9-foot ceiling.

1. Calculate room size in cubic feet.
length \times width \times height = cubic feet

_____ \times _____ \times _____ = _____ cubic feet
2. Determine the number of air changes per hour for the application (see Table 1 below) _____ air changes
3. Determine CFM requirements

$$\frac{L \times W \times H \times \text{air changes per hour}}{60 \text{ minutes}} = \text{total CFM required}$$

_____ cubic feet \times _____ air changes divided by 60 = _____ CFM required
4. CFM required divided by CFM rating of the model used = units needed (For this job a unit having a rating of 400 CFM has been selected)

_____ CFM required divided by _____ CFM of the unit = _____ CFM units needed

Table 1

LOAD	APPLICATION	AIR CHANGES PER HOUR
Light	Offices Restaurants	4
Average	Bingo halls Lounges	6
Heavy	Autobody Welding	8-10

- Have your instructor check your calculations.

**LIGHT COMMERCIAL AIR TREATMENT
UNIT VIII**

ANSWERS TO ASSIGNMENT SHEET #1

1. $30 \times 40 \times 9 = 10,800$
2. 4
3. $10,800 \times 4$ divided by 60 = 720 CFM
4. 720 divided by 400 = 2 units needed

**LIGHT COMMERCIAL AIR TREATMENT
UNIT VIII**

TEST

Name _____ Score _____

1. Match the terms on the right with their correct definitions.

- | | | | |
|---------|--|-----|-----------------------------|
| _____a. | The catching of airborne contaminants so they can be eliminated | 1. | Unducted |
| _____b. | Removal of contaminants from an airstream | 2. | Ozone |
| _____c. | Relative ability of an air cleaner to collect a given contaminant, usually expressed as a percentage | 3. | Halon |
| _____d. | Capturing the contaminant at its source and exhausting it outdoors | 4. | Capture |
| _____e. | Direct pick up of an airborne contaminant at the source, and the use of ductwork to convey contaminated air to a cleaner | 5. | Automatic mechanical filter |
| _____f. | A self contained air cleaner having its own blower, cleaning and recirculating room air without the use of hoods, ducts, pickups, or enclosures | 6. | Steam type humidifier |
| _____g. | Filtering device that replenishes the filter media automatically | 7. | Local ventilation |
| _____h. | Pungent, colorless gas; an unstable form of oxygen emitted in small amounts by an electronic air cleaner | 8. | Source capture |
| _____i. | A humidifier using an electric element to vaporize the water | 9. | Air-to-air exchanger |
| _____j. | Device for exhausting stale air, bringing in fresh air, and recovering some of the heating or cooling that normally would be lost in the process | 10. | Efficiency |
| | | 11. | Collection |

TEST

2. Complete statements concerning comfort level in a light commercial structure. Circle the material that best completes each statement.
- A clean, comfortable atmosphere for workers could mean less (absenteeism) (discomfort) and greater productivity.
 - A more pleasant, comfortable place to conduct business with customers could (maintain) (increase) business.
 - Some items must be kept at specific levels of humidity, temperature, and free from (direct sunlight) (contaminants).
3. Select true statements concerning air cleaners and existing light commercial applications. Place an "X" beside each true statement.
- Air cleaners can almost always be effectively added to existing light commercial structures.
 - Most air handling systems circulate air fast enough to maintain an acceptable level of cleanliness.
 - In structures where significant smoke is generated, an air cleaner is a good removal device.
 - Most HVAC systems cycle, but air cleaning equipment should operate continuously.
 - An air cleaner is a total air processing system.
 - An air cleaner may actually reduce the fresh air requirement, and fresh air make-up should be a careful consideration in system design.
4. Complete statements concerning common electronic air cleaning devices for light commercial applications. Circle the material that best completes each statement.
- A source capture system picks up airborne contaminants at their source and uses (ductwork) (a hallway) to convey the contaminants to an air cleaner.
 - Source capture systems work well with airborne contaminants produced by such contaminant sources as painting, grinding, woodworking, and (welding) (cooking).
 - Because a source capture system must be close to the source of the contaminant, it requires four essential parts:
 - A source capture device usually a (hood) (duct)
 - (Ductwork) (double plenums)

TEST

- 3) An (inlet) (outlet) diffuser plenum
- 4) (An air cleaner) (a humidifier)
- d. A totally enclosed air cleaner "boxes in" the contaminant source so that it can escape only through (a duct leading to a cleaner) (a plenum).
- e. A hooded application allows contaminants to escape to ambient air at the source, but captures the contaminants before they drift away, and (blows) (ducts) them to a cleaner.
- f. Unducted cleaners are self-contained units with their own blowers, but they do not use pickups, hoods, enclosures, or (ductwork) (plenums).
- g. Unducted cleaners recirculate room air, and because they are frequently ceiling or wall mounted, (placement) (size) is important.
5. Complete statements concerning performance factors for air cleaner applications. Circle the material that best completes each statement.
- a. Efficiency should be a (major) (minor) consideration in air cleaner selection, and efficiency should be determined by a reliable method.
- b. Required air changes per hour should be calculated according to (the load of the conditioned space) (previous installations).
- c. Air cleaner capacity needs to deliver the proper (FFM) (CFM), and the capacity rating is based on the amount of air the blower can deliver inside the cabinet.
- d. Air cleaners must be sized and placed to create (CFM) (air patterns) which will maximize their performance.
6. Identify basic air patterns for air cleaners. Place a "C" beneath the illustration of a ceiling air sweep pattern and a "P" beneath the illustration of a peripheral air pattern.

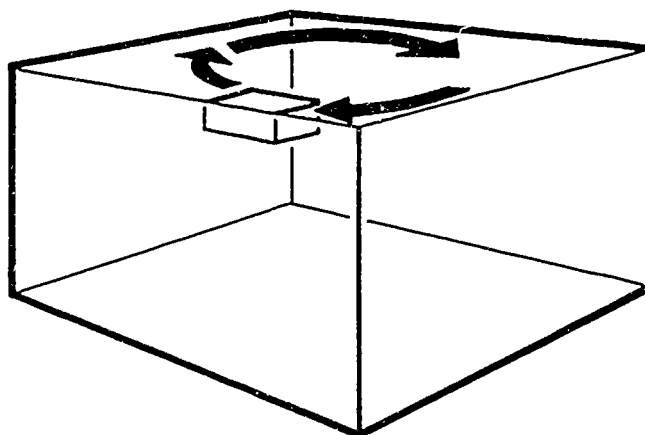

a. _____

TEST

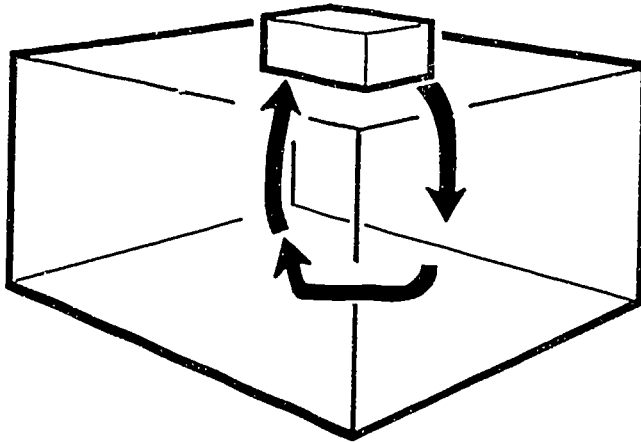

b. _____

7. Select true statements concerning capacity sizing. Place an "X" beside each true statement.
- ____ a. Sizing means knowing both the physical size of a structure and the load and air changes the load will require.
 - ____ b. Sizing should include measuring the space and determining the cubic footage.
 - ____ c. Sizing should include a careful evaluation of the load, taking into account the color of inside walls.
 - ____ d. Sizing must include a determination of the per hour requirements for air changes, and an air change table should always be referenced.
8. Complete statements concerning mechanical filters. Circle the material that best completes each statement.
- a. Mechanical commonly refers to how a filter is (replaced) (installed).
 - b. Many filters are throwaway types which need replacement (as service demands) (once a month).
 - c. Permanent mechanical filters usually have to be washed/cleaned at (a special shop) (intervals).
 - d. Automatic filters are replaced by filter material from a roll that is advanced across the filter face with a (motor-driven gear assembly) (lever).

TEST

9. Solve problems concerning humidification for light commercial applications. Select the best solution to each of the following problems.
- a. A conditioned space will house 12 personal computers which will be used 8 hours a day, 5 days a week. What kind of planning covers this? _____.
 - 1) Structural components
 - 2) Use factors
 - 3) Storage factors
 - b. A conditioned space has a cathedral-type ceiling. What kind of planning covers this? _____.
 - 1) Structural components
 - 2) Use factors
 - 3) Storage factors
 - c. A conditioned space will be used to maintain company records, some on floppy disks, some on paper. What kind of planning covers this? _____.
 - 1) Structural components
 - 2) Use factors
 - 3) Storage factors
10. Complete statements concerning air-to-air exchangers for light commercial structures. Circle the material that best completes each statement.
- a. Air-to-air exchangers are popular in light commercial applications because they serve the dual purpose of providing fresh air and (also providing make-up air) (conserving energy).
 - b. One advantage of an air-to-air exchanger is its ability to replace stale air with fresh air without losing all the (stale air) (heated air or cooled air) from inside.
 - c. Another advantage of an air-to-air exchanger is that it may be used to pick up contaminants in the area (near a grille) (where they are generated) and exhaust them along with stale air.

(NOTE: If the following activity has not been accomplished prior to the test, ask your instructor when it should be completed.)

11. Determine the number of electronic air cleaners needed for an office area. (Assignment Sheet #1)

LIGHT COMMERCIAL AIR TREATMENT
UNIT VIII

ANSWERS TO TEST

1.

a.	4	f.	1
b.	11	g.	5
c.	10	h.	2
d.	7	i.	6
e.	8	j.	9

2.

a.	Absenteeism
b.	Increase
c.	Contaminants

3. d, f

4.

a.	Ductwork
b.	Welding
c.	1) Hood
	2) Ductwork
	3) Inlet
	4) An air cleaner
d.	A duct leading to a cleaner
e.	Ducts
f.	Ductwork
g.	Placement

5.

a.	Major
b.	The load of the conditioned space
c.	CFM
d.	Air patterns

6.

a.	P
b.	C

7. a, b, d

8.

a.	Replaced
b.	As service demands
c.	Intervals
d.	Motor-driven gear assembly

ANSWERS TO TEST

9. a. 2
b. 1
c. 3
10. a. Conserving energy
b. Heated air or cooled air
c. Where they are generated
11. Evaluated according to answers to assignment sheet #1



STANDARD GAS-FIRED FURNACES UNIT IX

UNIT OBJECTIVE

After completion of this unit, the student should be able to install and service a gas-fired furnace as well as retrofit a standing pilot furnace with automatic ignition. These competencies will be demonstrated by completing the assignment and job sheets, and by scoring a minimum of 85 percent on the unit test.

SPECIFIC OBJECTIVES

After completion of this unit, the student should be able to:

1. Match terms related to gas furnaces with their definitions.
2. Complete statements concerning furnace classifications.
3. Solve problems concerning gas furnace safety.
4. Identify parts of the combustion triangle.
5. Match types of gas furnaces with their applications.
6. Identify major components of a standing pilot furnace.
7. Match automatic ignition systems with their operations.
8. Identify components of a gas burner assembly.
9. Match types of gas valves with their characteristics.
10. Identify components of a combination electric gas valve.
11. Select true statements concerning characteristics of heat exchangers.
12. Select true statements concerning characteristics of draft diverters.
13. Identify types of blower assemblies.
14. Select from a list components of a control system.
15. Complete statements concerning the functions of a transformer.
16. Match types of thermostats with their functions.

OBJECTIVE SHEET

17. Select true statements concerning limit switch operation.
18. Select true statements concerning fan switch operation.
19. Select true statements concerning combination fan-limit switch operation.
20. Describe pilot light operation.
21. Describe thermocouple operation.
22. Describe pilot safety operation.
23. Select true statements concerning potential sources for thermocouple failure.
24. Solve problems concerning potential sources of fan switch failure.
25. Solve problems concerning potential sources of transformer failure.
26. Solve problems concerning potential sources of high limit switch failure.
27. Solve problems concerning potential sources of gas valve failure.
28. Select true statements concerning potential sources of fan relay failure.
29. Match potential blower section failures with component sources.
30. Differentiate between potential sources of heat exchanger failure.
31. Select true statements concerning potential sources of pilot safety failure.
32. Complete a list of factors needed to determine gas pipe sizing.
33. Complete a list of energy conservation devices designed for retrofitting.
34. Select true statements concerning set back thermostats.
35. Select true statements concerning intermittent ignition systems.
36. Select true statements concerning vent dampers and their uses.
37. Select true statements concerning combustion air for a gas furnace.
38. Trace the high and low voltage circuits of a gas furnace. (Assignment Sheet #1)
39. Construct wiring diagrams for gas furnaces. (Assignment Sheet #2)
40. Size a gas piping system. (Assignment Sheet #3)
41. Demonstrate the ability to:
 - a. Install a gas furnace. (Job Sheet #1)

OBJECTIVE SHEET

- b. Start and adjust a gas furnace. (Job Sheet #2)
- c. Disassemble, inspect, and reassemble an upflow gas furnace. (Job Sheet #3)
- d. Perform maintenance on a gas furnace. (Job Sheet #4)
- e. Troubleshoot a gas furnace on a "no heat" complaint. (Job Sheet #5)
- f. Install a retrofit package to replace a standing pilot with a cycling pilot. (Job Sheet #6)

**STANDARD GAS-FIRED FURNACES
UNIT IX****SUGGESTED ACTIVITIES**

- A. Obtain additional materials and/or invite resource people to class to supplement/reinforce information provided in this unit of instruction.

(NOTE: This activity should be completed prior to the teaching of this unit.)

- B. Make transparencies from the transparency masters included with this unit.
- C. Provide students with objective sheet.
- D. Discuss unit and specific objectives.
- E. Provide students with information and assignment sheets.
- F. Discuss information and assignment sheets.

(NOTE: Use the transparencies as needed to enhance the information.)

- G. Provide students with job sheets.
- H. Discuss and demonstrate the procedures outlined in the job sheets.
- I. Integrate the following activities throughout the teaching of this unit:
1. Invite a factory or distributor representative to discuss new furnace types.
 2. Invite local inspector to discuss requirements to meet local codes especially furnace installation and proper venting.
 3. Demonstrate the use of gas furnace test equipment, especially an inclined manometer and a combustion test kit.
 4. Meeting individually with students to evaluate their progress through this unit of instruction, and indicate to them possible areas for improvement.
- J. Give test.
- K. Evaluate test.
- L. Reteach if necessary.

SUGGESTED ACTIVITIES

REFERENCES USED IN DEVELOPING THIS UNIT

- A. Althouse, Andrew D., and Carl H. Turnquist and Alfred C. Bracciano. *Modern Refrigeration and Air Conditioning*, South Holland, IL: The Goodheart-Wilcox Company, Inc., 1988.
- B. Air Conditioning and Refrigeration Institute, *Refrigeration and Air Conditioning*, Second edition, Arlington, VA: Prentice-Hall, 1987.
- C. Eckes, William, and Dan Fulkerson. *Air Conditioning and Refrigeration, Book Four*. Stillwater, OK 74074: Mid-American Vocational Curriculum Consortium, 1981.
- D. *Servicing and Installing Natural Gas Appliances*. Tulsa, OK: Oklahoma Natural Gas Company, 1984.
- E. "Bacharach Gas Burner Combustion Testing, Bulletin 4006." Pittsburg, PA 15238: Bacharach, Inc., 1987.

SUGGESTED SUPPLEMENTAL MATERIAL

- A. Bacharach, Inc., of Pittsburg has free product information available in its publications, "A Catalog of Testing & Measurement Instruments for Heating, Ventilation, Air Conditioning and Refrigeration", and "A Catalog of Testing Instruments for the Combustion Process." The address is given in B.
- B. Bacharach also has available a hand-held calculator to speed the process of determining combustion efficiency. The materials in A and the calculator are available from: Bacharach, Inc., 625 Alpha Drive, Pittsburg, PA 15238-2878, or telephone (412) 963-2000 for information.

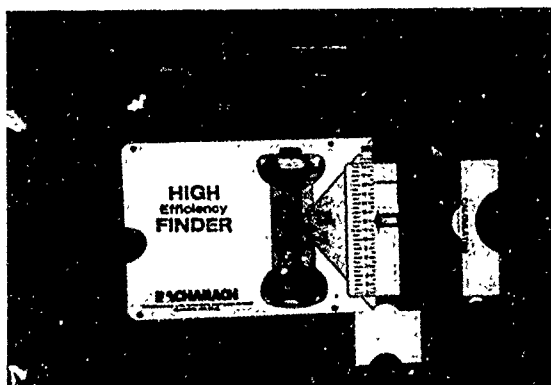

Bacharach's Combustion Efficiency Calculator

SUGGESTED ACTIVITIES

- C. Sizing tables for mid-efficiency, Category 1 furnaces such as the ones discussed in this unit of instruction have been revised. Until the revisions can be published, manufacturers of such equipment will ship the new sizing tables along with the appliances. The tables themselves will be available in 1992, but in the meantime, the American Gas Association has a slide/cassette tape program designed to show the new tables and how to use them with furnaces and other gas appliances. The program is titled "Improved Gas Vent Sizing Tables: An Introduction." For information about the new sizing tables, call AGA at (216)524-4990 or write to:

Training Department
American Gas Association Laboratories
8501 E. Pleasant Valley Road
Independence, OH 44131

- D. Local or area gas utilities may have the new vent sizing materials available. Check with the training personnel at your nearest gas utility for information and the possibility that a trainer could present the information to your class.

**STANDARD GAS-FIRED FURNACES
UNIT IX**

INFORMATION SHEET

I. Terms and definitions

- A. **Gas pressure regulator** — A device for adjusting gas line pressure to the pressure specified by the appliance manufacturer
- B. **Pilot safety control** — An electric switch which prevents a gas valve from opening unless a pilot light is present
- C. **Solenoid valve** — An electrical device that controls the flow of gas; can be millivolt, 24V, or 115V depending on application

(NOTE: A solenoid valve is normally closed and opens when the circuit is completed.)
- D. **Orifice inserts** — Plugs threaded or pressed into gas burner manifolds; their small, precisely drilled holes meter precise amounts of gas to individual burners
- E. **Primary shutter** — An adjustable opening on a gas burner which meters the amount of air to mix with the gas in order to produce a proper flame
- F. **Pilot runner (crossover igniter)** — A small opening in a gas burner which diverts a small amount of gas to the vicinity of the pilot flame to assist in a quick, even lighting of all burners in a gas furnace
- G. **Thermocouple** — Serves as a safety device on gas furnaces to cut off the gas supply in the event of loss of flame in the pilot light
- H. **High limit switch** — An electrical device on gas furnaces that cuts off the gas supply if the furnace overheats
- I. **Bonnet** — An air collection chamber
- J. **Gas valve** — An electrically operated valve that controls the flow of gas
- K. **Retrofit** — To remodel or repair; in HVAC it generally means replacing older system components with new components that conserve energy and upgrade the system
- L. **Combustion** — Rapid oxidation of fuel accompanied by the production of heat or light or both
- M. **Combustion triangle** — Fuel, oxygen, and ignition temperature; three conditions that must be present for combustion
- N. **AFUE** — Annual fuel utilization efficiency expressed as a percentage

INFORMATION SHEET

- O. **Liquefied petroleum gases (L.P. gas)** — Butane, propane, or a mixture of the two
- P. **ECO (Emergency Cutoff)** — Device to interrupt furnace operation if the temperature exceeds normal operation
- Q. **Thermopile** — A device capable of generating up to 500 mV so it can operate a gas valve without need of an electrical source

(NOTE: The thermopile also acts as a safety device to cut off the gas supply in the event of pilot failure.)
- R. **Redundant** — A gas valve that actually has dual valves so that either valve can shut off the gas supply in the event of pilot or ignition failure
- S. **Flue temperature switch** — A switch located in the flue to shut down the gas valve in the event flue temperature reaches an unsafe level
- T. **Flame rollout switch** — A switch located near the burner assembly so it can sense when flames begin to roll out the front of the furnace and shut off the gas supply
- U. **Blower door interlock switch** — A switch which interrupts the electrical power source and shuts down the entire system if the blower compartment door is open

II. **Furnace classifications**

- A. Furnaces are generally classified according to their AFUE (annual fuel utilization efficiency) which is expressed as a percentage.
- B. Generally, standard gas-fired furnaces have an efficiency below 78% and high-efficiency gas-fired furnaces have an efficiency above 78%.

(NOTE: Standard gas-fired furnaces do range in efficiency from 65% to 78%, but mid-efficiency standard furnaces may have efficiency ratings as high as 82%. Both groups of standard furnaces are rated as Category 1 furnaces by the National Fuel Gas Code whose furnace categories are detailed in Handout #1.)

- C. Standard gas-fired furnaces usually have standing pilots or automatic ignition pilots which fire the main gas burners.
- D. High efficiency gas-fired furnaces may be induced draft furnaces, pulse furnaces, or condensing furnaces with components and design that promote high efficiency.

(NOTE: This unit of instruction concerns itself with standard gas-fired furnaces. High-efficiency gas-fired furnaces are presented in Unit X and oil-fired furnaces are presented in Unit XI.)

INFORMATION SHEET

III. Gas furnace safety

- A. Never attempt to bypass safety controls on a gas furnace.
- B. Never replace furnace components, especially safety devices, with components that are not approved by the manufacturer.
- C. LP gas furnaces and all LP gas equipment should be installed and serviced only by a qualified LP technician.

(**CAUTION:** LP gas is heavier than air and will not dissipate like natural gas. It can build up in low places around furnaces and appliances and create a hazard. Some states require LP service technicians to be licensed.)

- D. Always follow manufacturers recommendation for venting and for providing combustion air and ventilation. (See Handout #1)

IV. Combustion triangle — In order for combustion to occur, three conditions must be present: (Figure 1)

- A. Fuel
- B. Oxygen (air)
- C. Heat (ignition temperature)

FIGURE 1

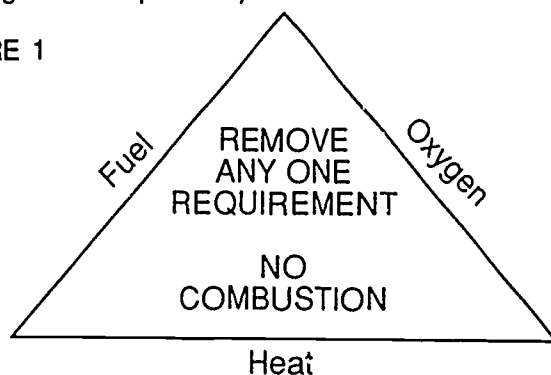

Courtesy Inter-City Products Corporation (USA)

V. Types of gas furnaces and their applications

- A. Upflow — Installed where headroom is not a problem (Transparency 1)

(NOTE: When installed in closets, upflow furnaces require special clearances from combustible materials.)
- B. Counterflow — Installed where basement or crawl space cannot be used, and supply ducts are located under the floor (Transparency 2)

(NOTE: When a counterflow furnace is installed on a combustible floor, it requires a special supply adapter.)

INFORMATION SHEET

- C. Horizontal — Installed in crawl space or attic where headroom is limited (Transparency 3)

(NOTE: Heat exchangers in horizontal furnaces are subjected to greater stress than heat exchangers in other furnace types.)

- D. Outdoor — Installed outside and ducted into the structure

(NOTE: Because these units are usually a combination furnace-air conditioner, they are called "package units," and they are usually vented by a draft inducer instead of gravity.)

- E. Lowboy — Installed in basements where headroom is limited (Transparency 4)

(NOTE: Lowboy furnaces have horizontal heat exchangers.)

VI. Major components of a standing pilot furnace (Transparency 5)

- A. Combustion chamber
- B. Burner assembly
- C. Flue
- D. Heat exchanger
- E. Draft diverter
- F. Blower assembly
- G. Air filter
- H. Cabinet
- I. Blower door interlock switch
- J. Control compartment

VII. Types of automatic ignition systems and their operations (Transparency 6)

- A. Direct spark ignition (DSI) — On a call for heat, gas, at a reduced pressure is sent to a burner where a high voltage spark ignites the gas directly; the electronic module then allows the gas valve to increase manifold pressure to the burners.

(NOTE: With automatic ignition, the pilot burner does not operate during the OFF cycle, and furnaces with automatic ignitions systems, with few exceptions, are similar to standing pilot furnaces.)

INFORMATION SHEET

- B. Hot surface ignition (HSI) — Works much like a direct spark ignition system except that a hot surface is used to ignite the gas instead of a spark and the ignition works off line voltage.

(NOTE: If polarity is wrong in an HSI system, the system goes into a "nuisance" lockout. Changing polarity will correct the problem.)

- C. Spark to pilot to burner — On a call for heat, gas is sent to the pilot burner where it is ignited by a high voltage spark; when the pilot is established, the electronic module allows the main gas valve to open.

VIII. Components of a gas burner assembly (Transparency 7)

- A. Gas valve
- B. Pilot assembly (may not be present on automatic models)
- C. Manifold and orifices
- D. Primary air shutter
- E. Burners — ribbon, slot, tubular or jet
- F. Pilot runner or crossover igniters
- G. Pilot burner and thermocouple assembly (may not be present on automatic models)
- H. Tap for measuring manifold pressure

IX. Types of gas valves and their characteristics

- A. Instantaneous — Opens instantly when energized
- B. Slow opening — Opens after a lapse of one to thirty seconds when energized
- C. Step opening — Opens at reduced pressure and then steps up to full manifold pressure
- D. Combination — Combines other gas burner assembly components such as a pilot gas valve and pilot safety
- E. Redundant — A valve with two main gas valves in one body so that both valves open and close on every call for heat to assure shutdown in the event of pilot or ignition failure

(NOTE: Since 1979, ANSI (American National Standard Institute) has required a dual valve system in all furnaces manufactured after that date, and older furnaces can usually be retrofitted with a redundant gas valve.)

INFORMATION SHEET

- X. Components of a combination electric gas valve (Transparency 8)**
- A. Pilot shut off valve and safety reset/lighting button
 - B. Main gas line shut off
 - C. Pilot gas adjustment
 - D. Gas pressure regulator adjustment
 - E. Pilot gas connection
 - F. Thermocouple connection (with built-in electromagnetic pilot safety control)
 - G. Electrical terminals (to control circuit)
 - H. Inlet/outlet pressure taps
- XI. Characteristics of heat exchangers**
- A. Constructed to provide efficient heat transfer from the burner to air in the exchanger while keeping flue gases separate from air circulated in the duct system
 - B. May be composed of units called "clamshells" (Figure 2)

FIGURE 2

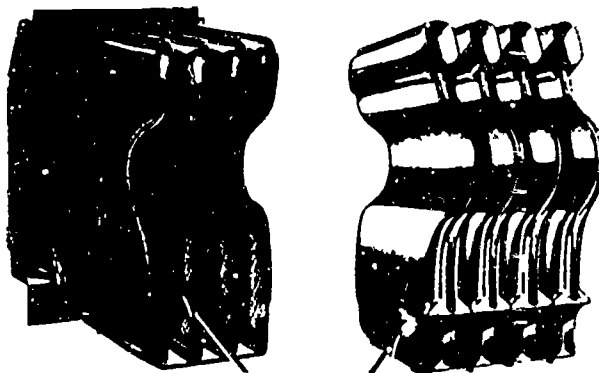

Clamshells

Courtesy of Lennox Industries, Inc.

- C. Designed to transfer a specific amount of heat per hour of operation
- D. Each "clamshell" has one burner (Figure 3)

(There are several other types of heat exchangers — such as tubular, drum type, and ceramic coated, but the "clamshell" is probably the most common.)

INFORMATION SHEET

FIGURE 3

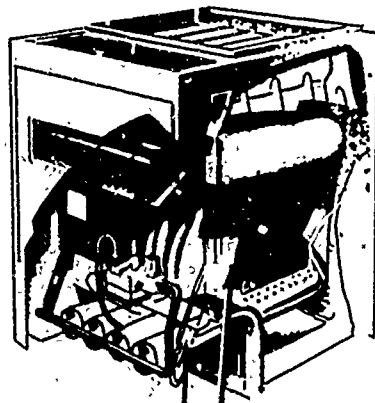

**Each Clamshell
Has One Burner**

Courtesy of Lennox Industries, Inc.

XII. Characteristics of draft diverters

- A. A draft diverter collects flue gases from the upper opening of a heat exchanger and funnels them into the vent without pulling excess air over the flames.
- B. A draft diverter should be open to the atmosphere.
- C. A draft diverter induces unheated air into vent pipe to reduce temperature of flue gases.
- D. A draft diverter prevents wind that enters the vent pipe from blowing out the pilot.

XIII. Types of blower assemblies

- A. Direct drive (Figure 4)

FIGURE 4

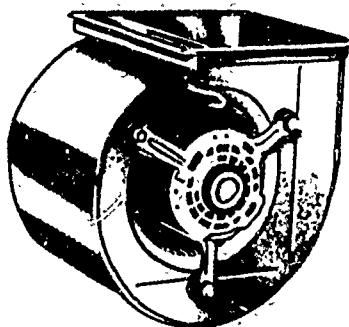

Courtesy Lennox Industries, Inc.

- 1. Approximately 1050 rpm on high speed
- 2. Supported by motor shaft
- 3. Variable speed requires a multi-speed motor

INFORMATION SHEET

B. Belt drive (Figure 5)

FIGURE 5

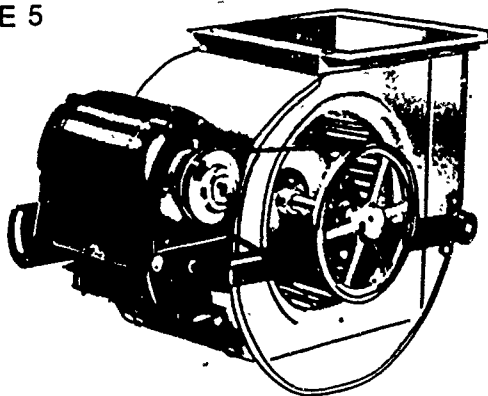

Courtesy Lennox Industries, Inc.

1. Motor is usually 1725 rpm
2. Blower wheel is supported by shaft and bearings
3. Variable speed is obtained by varying the setting of a split pulley

(NOTE: Blower assemblies are constructed to pull air through the return air ducts and filter, and push air through the heat exchanger and supply ducts; they require careful adjustment to produce enough volume and velocity to maintain comfort at design conditions; belt drives are more often used on light commercial applications.)

XIV. Components of a control system

- A. Transformer
- B. Thermostat
- C. Electric gas valve
- D. Limit switch
- E. Fan switch
- F. Combination fan-limit switch
- G. Pilot light
- H. Thermocouple
- I. Pilot safety

INFORMATION SHEET**XV. Functions of a transformer**

- A. Reduces supply voltage to 24 volts
- B. Furnishes power for control circuit
- C. A transformer used for both heating and cooling has a VA rating of 40.

XVI. Types of thermostats and their functions**A. Heat only thermostats**

- 1. Consists of one switch which closes on a drop in temperature
- 2. Have only a heat anticipator
- 3. May have a set back energy conservation feature

B. Heat and cool thermostats

- 1. Temperature operated heating switch closes on drop in room temperature
- 2. Temperature operated cooling switch closes on increase in room temperature
- 3. Operate on room temperature and heat from the anticipator
- 4. Manually operated fan switch closes circuit to fan relay
- 5. Have both heating and cooling anticipators
- 6. May have a set back energy conservation feature
- 7. May be snap action, Mercury bulb or electronic solid state type
- 8. Mercury bulb thermostats must be level and mounted firmly

C. Heat anticipator

- 1. Adds a small amount of heat in the thermostat during the "on" part of the heating cycle to prevent room overheating and narrows the mechanical differential of the thermostat
- 2. Should be set to match the current draw of the heating circuit or to the appliance manufacturer's recommended setting if known
- 3. Set too low causes short cycling

INFORMATION SHEET

4. Set too high causes too long a cycle resulting in a wide temperature differential
5. Is the weakest point in the heating circuit and may be ruined by careless "jumpering" of components when troubleshooting

XVII. Limit switch operation

- A. Opens on temperature rise
- B. Senses bonnet temperature
- C. Set at approximately 180 to 200 degrees depending on make and model
- D. Interrupts circuit to gas valve or transformer
- E. May be separate or combined with fan switch
- F. Designed to shut off gas supply to burners if furnace overheats
- G. In some models will bypass fan switch to bring on blower while furnace is overheated

XVIII. Fan switch operation

- A. Closes on temperature rise
- B. Senses bonnet temperature
- C. Adjustable "on" switch approximately 125 degrees
- D. Adjustable "off" switch approximately 20 to 30 degrees cooler than "on" switch

(NOTE: Some manufacturers use an electric fan switch with time delay to permit furnace to heat before closing blower circuit; this switch does not sense furnace bonnet temperature. Some also use a solid state control board instead of the controls discussed here.)

- E. All types of fan switches for gas furnaces are designed to close supply circuit to blower motor when furnace is hot
- F. May be combined with limit switch

XIX. Combination fan-limit switch operation

- A. Combines complete set of fan switches
- B. Contains pre-set high limit switch
 1. May control gas valve on 24 volts

INFORMATION SHEET

2. May control transformer supply circuit on house current of 115 volts

(CAUTION: Combination fan-limit switches are frequently converted from 115 volt to 24 volt operation and vice versa through the high limit switch; this must be recognized during service work to prevent destruction of the gas valve, transformer, or thermostat.)

XX. Pilot operation

- A. Small flame lights main burners when gas valve opens
- B. Furnishes heat to thermocouple tip

XXI. Thermocouple operation

- A. Converts heat from pilot into an electric current which controls the pilot safety
- B. Connects electrically to pilot safety

(NOTE: A thermopile operates like a thermocouple, but it generates up to 500 mV so it can operate the gas valve.)

XXII. Pilot safety operation

- A. Opens control circuit to gas valve in event pilot light fails
- B. May be incorporated into combination gas valve or installed as a separate device

XXIII. Potential sources of thermocouple failure

- A. May fail to generate enough voltage to hold open the gas valve or pilot safety
- B. Tip may be burned out because pilot flame is too hot
- C. May not be getting enough heat from pilot flame
 1. Not properly positioned in pilot flame
 2. Soot build up insulates thermocouple

XXIV. Potential sources of fan switch failure

- A. Contacts stick together making fan run all the time
- B. Fan switch temperature setting becomes unreliable causing fan to come on too soon or too late

(NOTE: In attic installations, the fan will come on in the summer if attic temperature rises above fan switch set point.)

INFORMATION SHEET**XXV. Potential sources of transformer failure**

- A. May burn out either in the primary or secondary windings
- B. Sometimes fails for no apparent reason

XXVI. Potential sources of high limit switch failure

- A. Normally closed switch that is faulty will not open in presence of unsafe temperature
- B. Usually very reliable, but might be prevented from operating because of external causes
 - 1. Switch cover jammed against moving plate
 - 2. Wires touching because of burned insulation

(CAUTION: Never bypass safety devices!)

XXVII. Potential sources of gas valve failure

- A. Usually fails because it will not open
- B. Rarely fails because it will not close

XXVIII. Potential sources of fan relay failure

- A. Contacts stick together causing blower to run all the time
- B. Fails to close when 24 volts is applied
- C. Contacts fail to close fan circuit

XXIX. Potential blower section failures and component sources

- A. Blower motors
 - 1. Bad capacitor
 - 2. Bearing seizure because of improper oiling
 - 3. Burned out or shorted motor windings
 - 4. Fireplace ducted into return air may cause motor to overheat
- B. Blower bearings
 - 1. Destroyed because of improper oiling
 - 2. Destroyed because of excessive belt tension

INFORMATION SHEET

- C. Blower belts
 - 1. Cracked, frayed, or broken
 - 2. Too loose
 - 3. Too tight
- D. Aluminum split pulleys — Can seize to motor shaft and cannot be pulled off without destruction
- E. Blower wheels out of balance
 - 1. Balance weight has come off
 - 2. Can only be rebalanced at the factory

(CAUTION: Never remove weights from a blower wheel because they cannot be properly replaced except as noted.)
- F. Blower wheel — Running backwards because of improper replacement
- G. Blower speed
 - 1. Creates excessive noise
 - 2. Causes temperature stratification resulting in cold spots and hot spots in the room
 - 3. Drawing too much current and blowing fuses
 - 4. Providing inadequate cooling after air conditioning has been added

(NOTE: This condition usually has to be corrected by replacing motor with a higher horsepower motor to facilitate the demand for added air volume.)

XXX. Potential sources of heat exchanger failure

- A. Soot build up between clamshells
 - 1. Usually identified by flames spilling out of furnace even if the blower is not running.
 - 2. Flames frequently cause extensive damage to wires and electrical components
 - 3. Usually requires furnace burner and baffle removal to clean between clamshells with wire and vacuum cleaner

(NOTE: A vacuum cleaner hose fitted with a soft copper tube is a handy tool to pick up soot and rust.)

INFORMATION SHEET

- B. Cracked heat exchanger
1. Usually starts as hairline cracks in sharper bends of clamshells
 2. Cracks open wider in presence of heat from burner flames and create a potential hazard for occupants
 3. Should be suspected when customer complains of pilot light blowing out
 4. Usually identified by flame distortion or flames spilling out front of furnace when the blower starts
 5. Identified by visual inspection with flashlight and small mirror
- (NOTE: It is frequently necessary to pull the burner assembly and blower assembly to properly examine a heat exchanger.)
6. Have customer sign service ticket that you advised them the heat exchanger is unsafe.
 7. Turn off gas supply and red tag the furnace to indicate the danger.

XXXI. Potential sources of pilot safety failure

- A. Usually evidenced by failure to open gas valve after replacement of thermocouple
- B. Kills power to gas valve unless operating properly with adequate thermocouple voltage
- C. On furnaces without 100% shut-off gas valves
- D. May be caused by downdrafts
- E. Inspect vent system if downdraft is present

XXXII. Factors needed to determine gas pipe sizing (Assignment Sheet #3)

- A. Specific gravity and Btu per cubic foot heating value of gas supply
 - B. Btuh rating of gas outlet
- (NOTE: This information is either on the rating plate or in manufacturer's specifications.)
- C. Distance from the gas meter to the appliance outlet
 - D. Maximum capacity of pipe related to cubic feet of gas per hour

INFORMATION SHEET

XXXIII. Energy conservation devices designed for retrofitting

- A. Set back thermostats
- B. Intermittent ignition systems
- C. Vent dampers

XXXIV. Set back thermostats

- A. Designed to let structure drop to a lower inside temperature during the setback period
- B. Reduces heat loss because of lower temperature differential during set back period
- C. Reduces fuel consumption because of reduced heat loss
- D. Can be manually operated by occupant upon retiring or getting up
- E. Can be fully automatic with clock operation and also provide a manual override feature
- F. Designed to allow structure temperature to rise during the "setback" period of the cooling mode which should result in a reduced operating cost

(NOTE: Discomfort may occur if the indoor temperature is allowed to swing too far during the setback period on a "design temperature" day due to inability to recover quickly.)

XXXV. Intermittent ignition systems

- A. Eliminates cost of fuel to pilot flame
- B. Can operate from a direct spark ignition, proven-pilot ignition, or cycling-pilot ignition

(NOTE: Refer to Job Sheet #6 for illustrations of a cycling-pilot ignition.)

- C. Good proven-pilot or cycling-pilot systems are built with a "redundant" safety system which requires that the pilot light be proven with an electric or an electro-mechanical sensor before gas will flow to the main burners
- D. Are being incorporated into new furnace designs

(CAUTION: Applications for intermittent ignition systems are different for natural and LP gas; manufacturer's installation specifications should be followed carefully on retrofit applications, and it is sometimes necessary to contact the furnace manufacturer to make sure the furnace can be retrofitted with the intermittent system.)

INFORMATION SHEET

XXXVI. Vent dampers and their uses (Figures 6 and 7)

- A. Are designed to stay open while burner is operating in order to vent combustion gases
1. May be thermal actuated
 2. May be actuated by a small motor

FIGURE 6

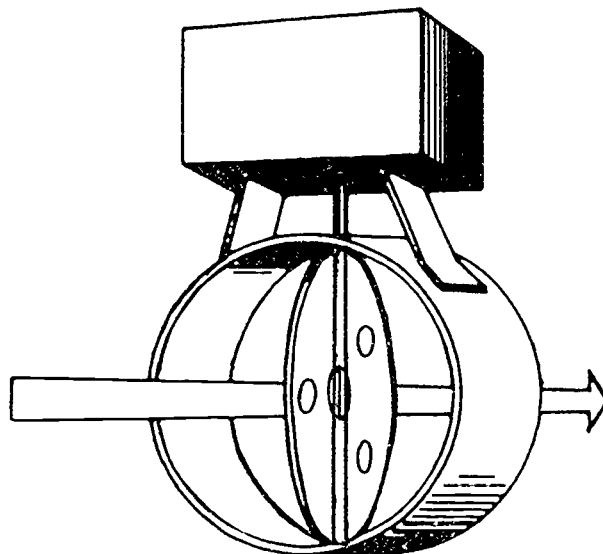

- B. Are designed to close when burner shuts off to stop heat from escaping up the flue or chimney (Figure 7)
- C. On a pilot furnace, a vent damper in the closed position should have small openings to allow pilot flue gases to escape

INFORMATION SHEET

FIGURE 7

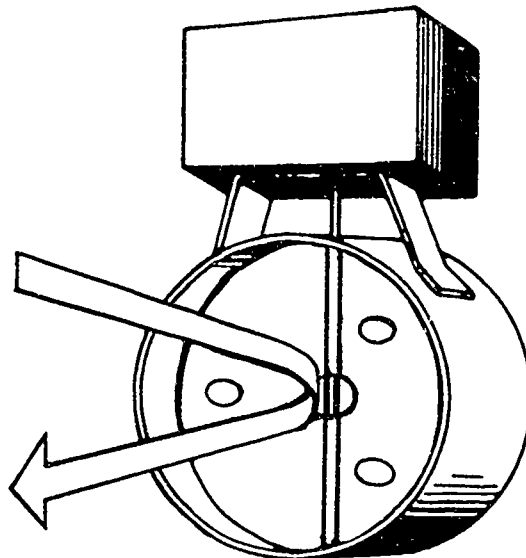

- D. Are relatively easy to install, but should only be installed by a licensed contractor

(CAUTION: Vent dampers can be both health and fire hazards if they fail to open when the furnace is operating, and some furnace warranties are voided if vent dampers are added; always check warranties to be safe, and always check local codes for regulations governing vent damper retrofit applications.)

- E. Some manufacturers are building furnaces with control wiring installed for adding a vent damper
- F. Vent dampers save energy if the furnace combustion air is drawn from the heated space

XXXVII. Combustion air for a gas furnace

- A. A furnace should be installed in a location that permits a proper supply of air for combustion and venting.
- B. The furnace location should also provide for proper ventilation to help maintain an ambient temperature at safe limits under normal operating conditions.
- C. The size of openings for combustion and ventilation depend on the location of the openings and the BTUH input to the furnace or appliance.

(NOTE: The National Fuel Gas Code from the National Fire Protection Association details combustion air requirements. Since the code is updated from time to time, you should check with your instructor for up-to-date information.)

Upflow Gas Furnace Typical Applications

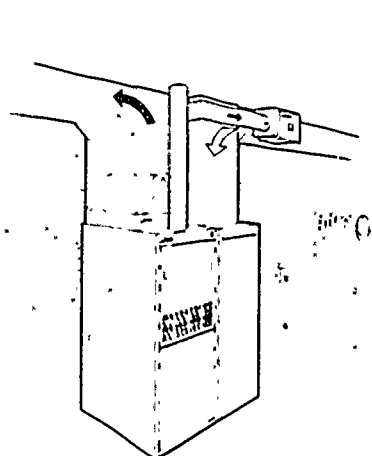

Basement Installation
with Cooling Coil,
Electronic Air Cleaner and Humidifier

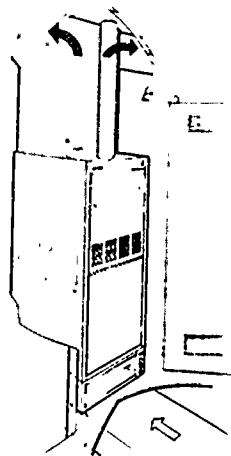

Closet Installation
with Cooling Coil
and Electronic Air
Cleaner

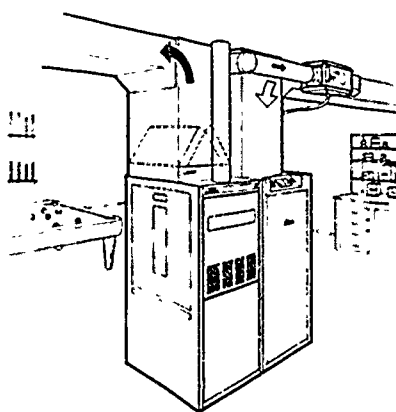

Basement Installation With
Cooling Coil, Return Air
Cabinet and Power Humidifier

Courtesy Lennox Industries, Inc.

Counterflow Gas Furnace Typical Applications

Utility Room Installation With
Cooling Coil, Electronic Air
Cleaner and Humidifier

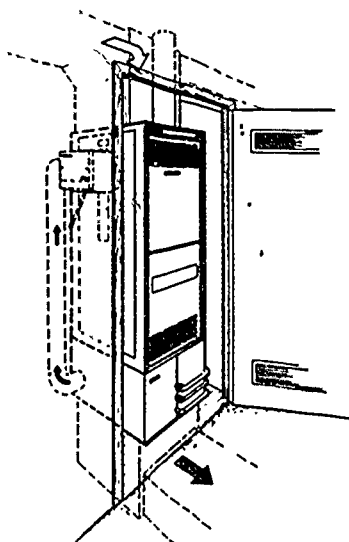
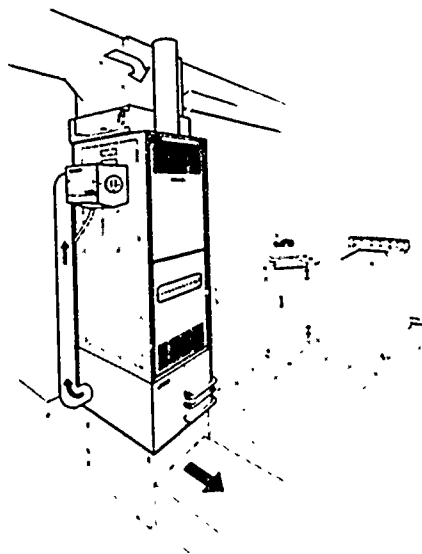

Closet Installation With
Cooling Coil and Humidifier

Courtesy Lennox Industries, Inc.

Horizontal Gas Furnace Typical Applications

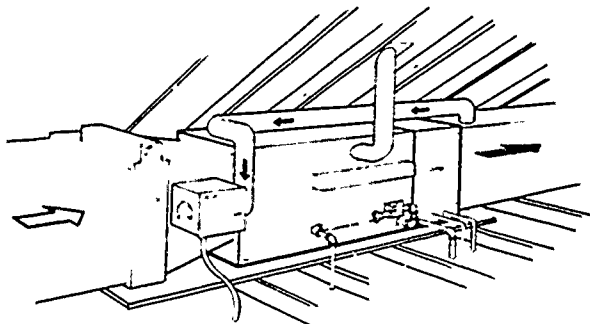

Attic Installation With
Cooling Coil, Electronic
Air Cleaner and Automatic
Humidifier

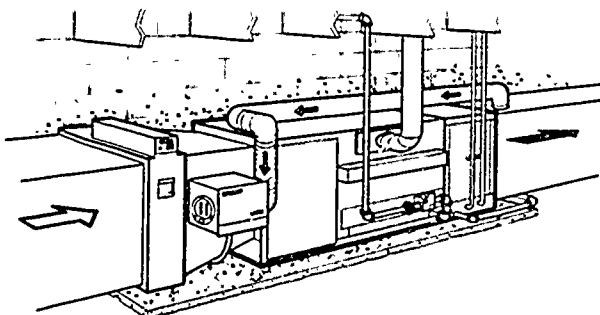

Crawl Space Installation
With Cooling Coil,
Electronic Air Cleaner and
Automatic Humidifier

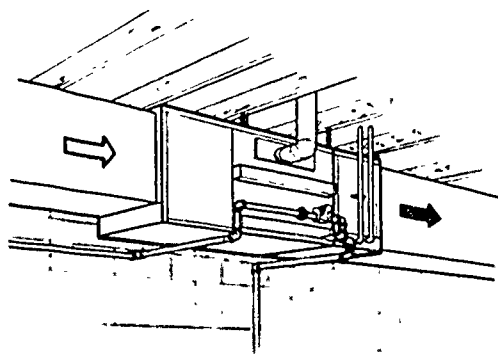

Basement Installation
With Cooling Coil

Courtesy Lennox Industries, Inc.

Lowboy or Basement Gas Furnace Typical Applications

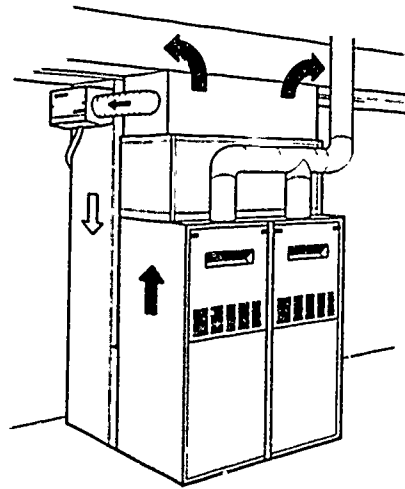

Twinned Furnace Installation
With Cooling Coil and Humidifier

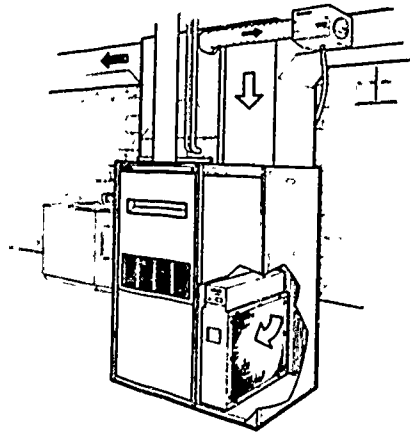

Basement Installation
With Cooling Coil,
Humidifier, Return Air
cabinet and Electronic
Air Cleaner

Courtesy Lennox Industries, Inc.

Gas-Fired Furnace Components

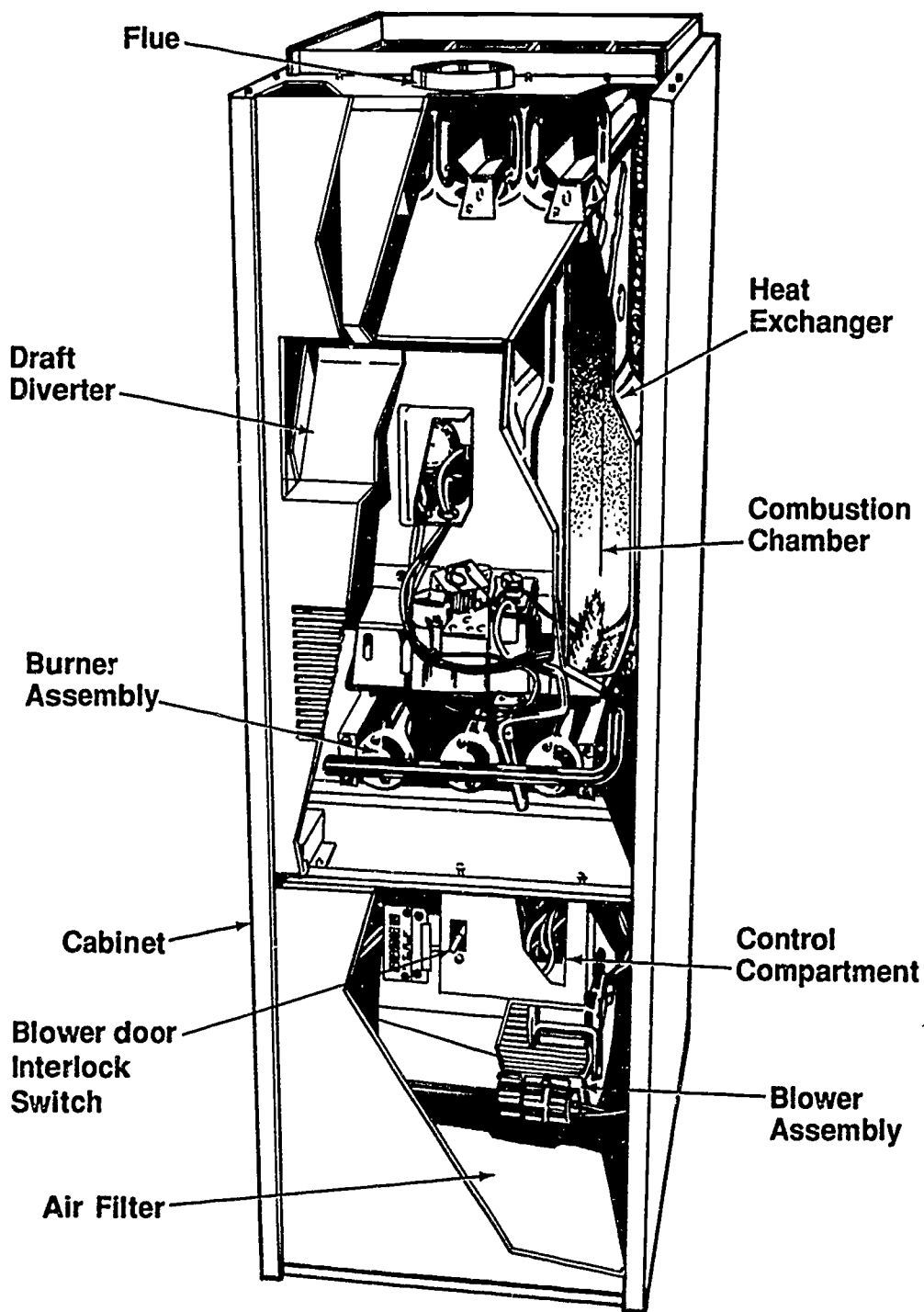

Courtesy Inter-City Products Corporation (USA)

Components of an Automatic Ignition Furnace

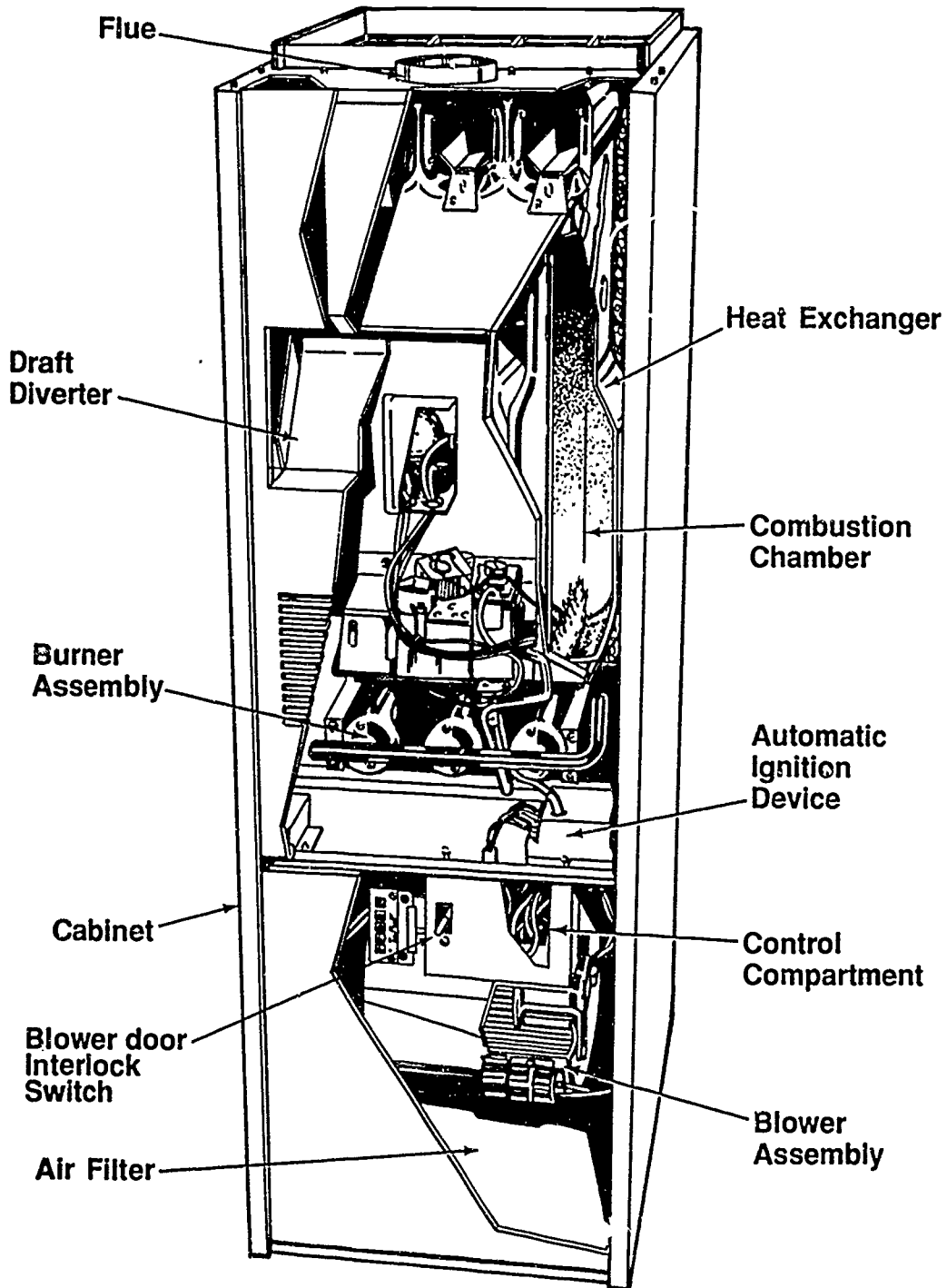

Courtesy Inter-City Products Corporation (USA)

Components of a Gas Burner Assembly

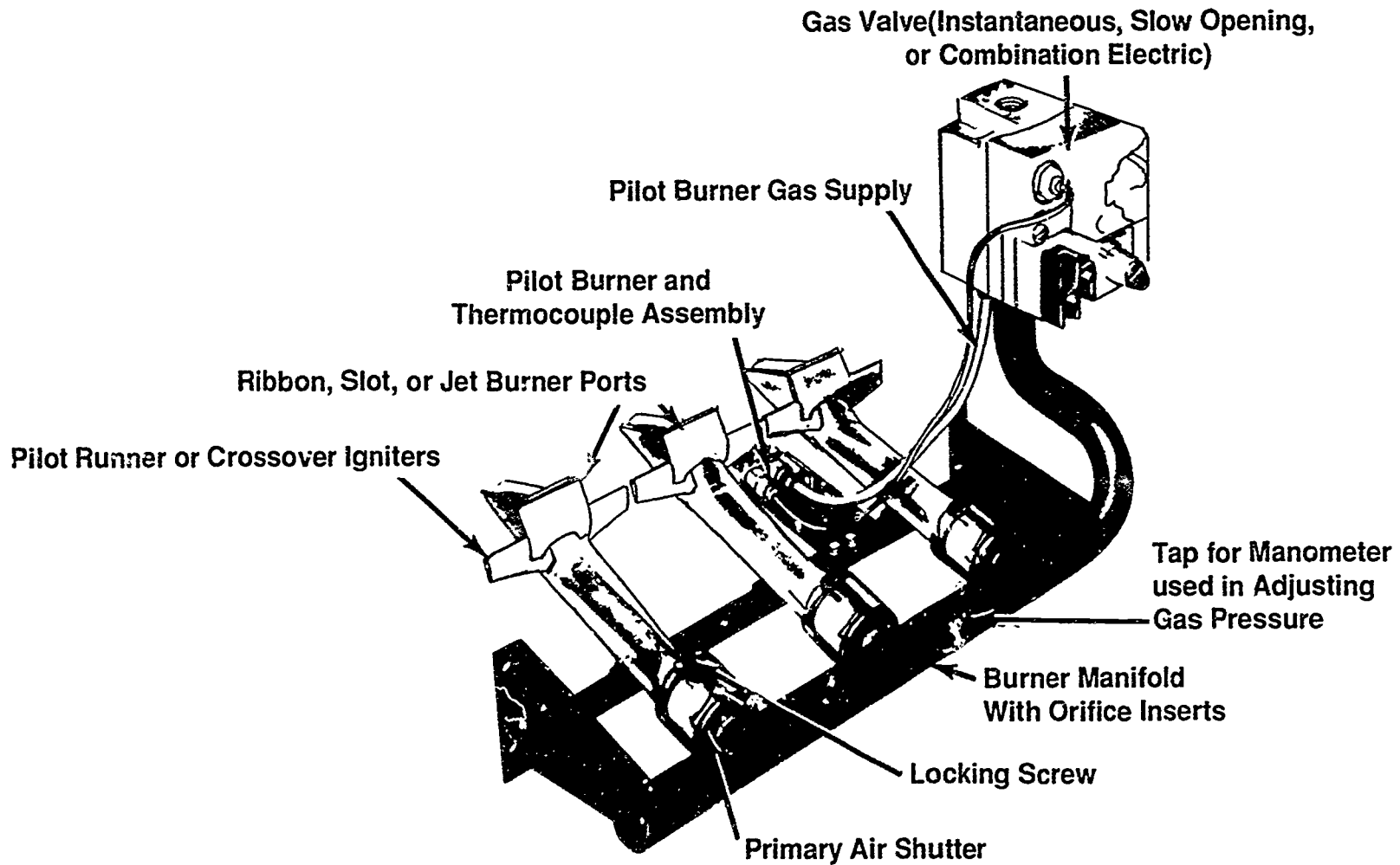

369

370

Components of a Combination Electric Gas Valve

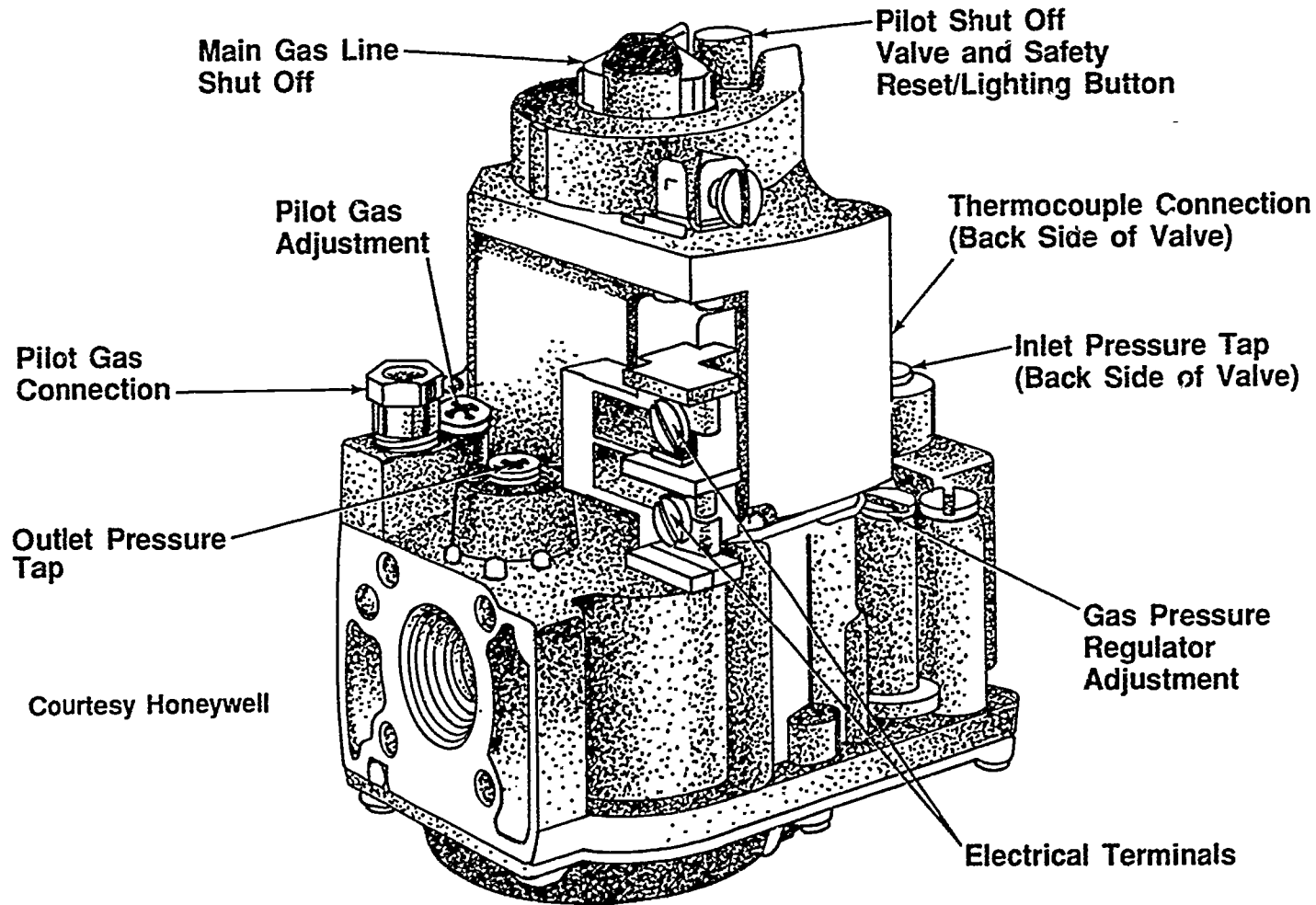

**STANDARD GAS-FIRED FURNACES
UNIT IX**

HANDOUT #1 — FURNACE CATEGORIES

Purpose

So that both manufacturers and installers will have common technical references, the National Fuel Gas Code places furnaces into categories determined by their performance characteristics. Since HVAC technicians will often see these categories referenced in manufacturers' literature, it will be beneficial to know what the categories are and how they are defined.

The four furnace categories

The furnace categories are based on whether the furnace has positive or negative vent pressure and if the flue gas temperature is above or below 140°F above dew point.

Category	Vent Pressure	Flue Gas Temperature
1	Negative	At least 140°F above dew point
2	Negative	Less than 140°F above dew point
3	Positive	At least 140°F above dew point
4	Positive	Less than 140°F above dew point

Performance characteristics

Category 1 furnaces are the standard gas-fired furnaces discussed in this unit of instruction. These furnaces have draft hoods and are connected to chimneys with metal vent pipes. No category 2 furnaces have been certified, but if any ever are, they will be highly efficient Category 1 furnaces. The induced draft furnace that is vented horizontally is a good example of a Category 3 furnace, and the condensing furnace, also vented horizontally, is an example of a Category 4 furnace. The furnaces in categories 3 and 4 are treated in Unit X, "High-Efficiency Gas-Fired Furnaces."

Venting characteristics

The venting characteristics of a furnace dictate installation and service requirements. With negative vent pressure the pressure inside the vent is less than the atmospheric pressure outside the vent so there is little chance flue gases could escape into a living space. With positive vent pressure the opposite is true. The pressure inside the vent is greater than the atmospheric pressure outside the vent and care has to be taken that flue gases do not escape into a living space. The low flue gas temperature in some category 3 and 4 furnaces produces another venting problem, condensation. The condensate has to be handled in some way and manufacturer's specifications should always be followed.

HANDOUT #1

Conclusion

The American Gas Association has developed a new set of "Venting Requirements for Category 1 Central Furnaces." These requirements were not available as of this printing, but the requirements will be included as part of the literature when manufacturers ship new product. In 1992, the requirements will be formally published. The new rules will be beneficial in avoiding oversizing and undersizing the venting for Category 1 furnaces.

STANDARD GAS-FIRED FURNACES
UNIT IX

ASSIGNMENT SHEET #1 — TRACE THE HIGH VOLTAGE
AND LOW VOLTAGE CIRCUITS OF A GAS FURNACE

1. Use a dark colored pencil on the following schematic to trace the high voltage circuit while the thermostat calls for heat.

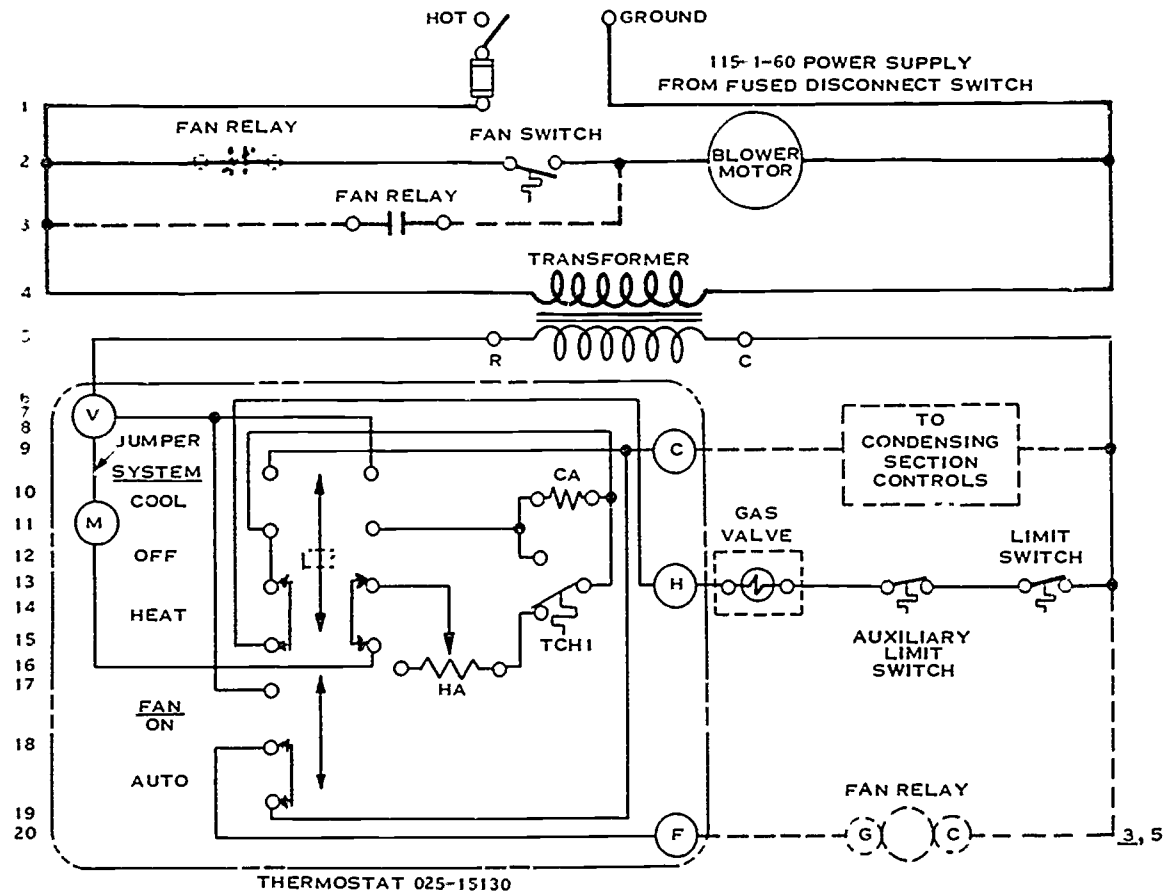

ASSIGNMENT SHEET #1

2. Use a dark colored pencil on the following schematic to trace the low voltage circuit while the thermostat calls for heat.

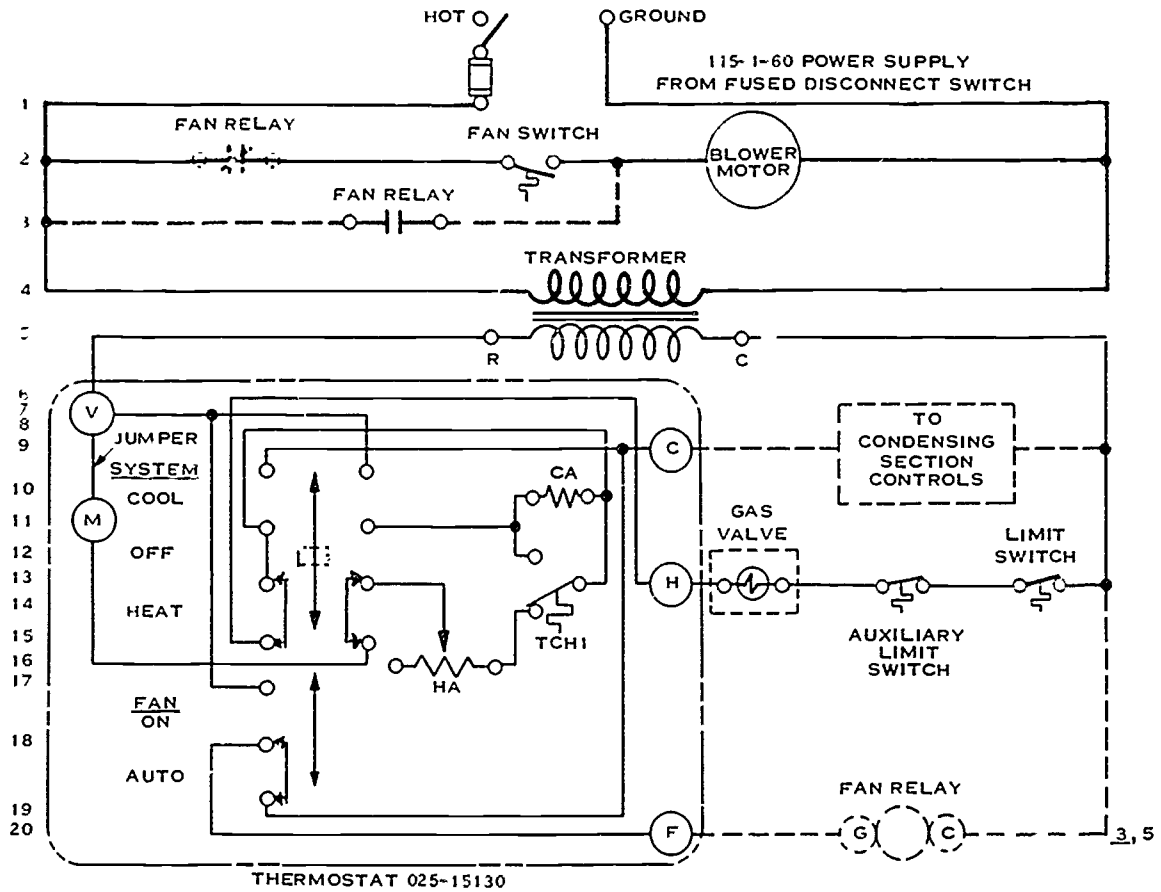

**STANDARD GAS-FIRED FURNACES
UNIT IX**

**ASSIGNMENT SHEET #2 — CONSTRUCT WIRING DIAGRAMS
FOR GAS FURNACES**

Directions: Draw lines representing wires connecting electrical components of a gas furnace in the following conditions:

1. "Heating Only" furnace with 24V high limit

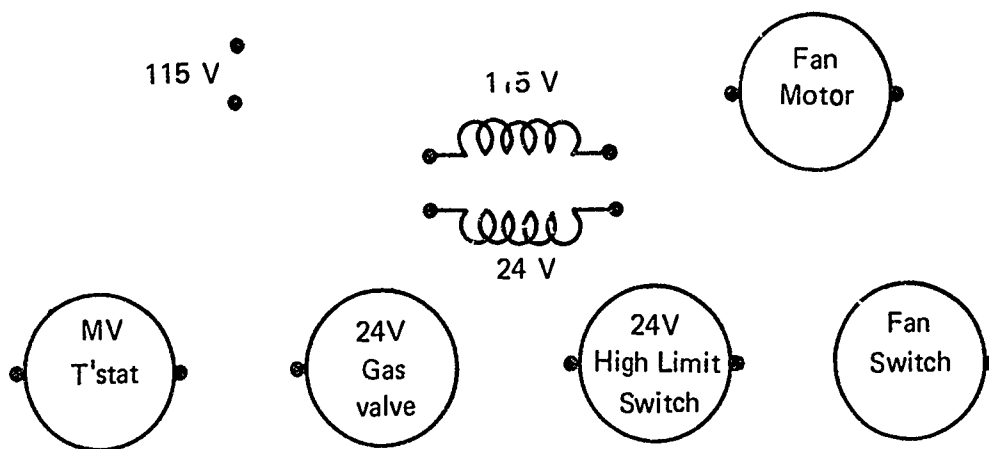

2. "Heating Only" furnace with 115V high limit

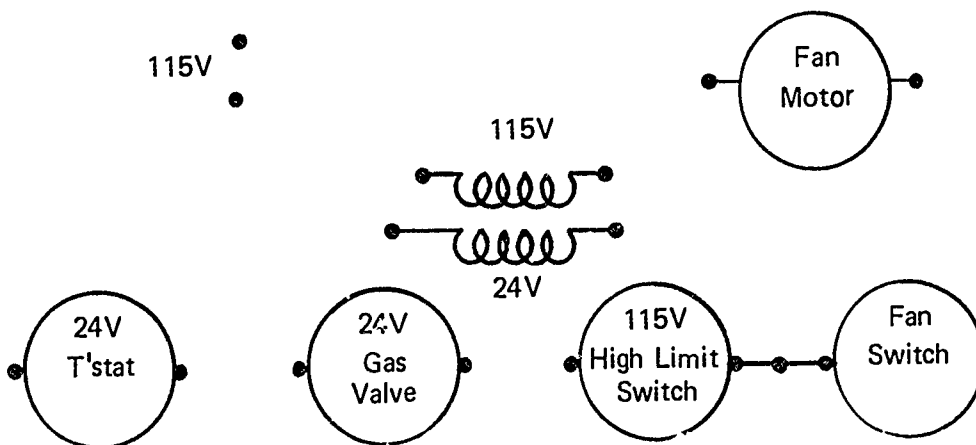

ASSIGNMENT SHEET #2

3. "Heating Only" furnace with millivolt gas valve

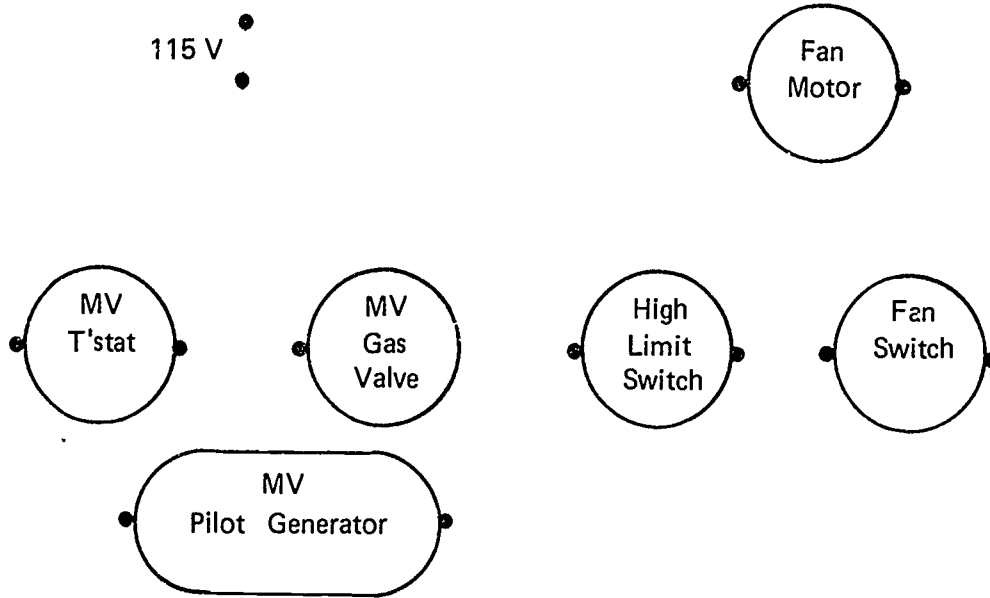

**STANDARD GAS-FIRED FURNACES
UNIT IX**

ASSIGNMENT SHEET #3 — SIZE A GAS PIPING SYSTEM

Directions: Use the pipe chart in Figure 1 and the piping system plan shown in Figure 2 to size a gas piping system. Place Figure 2 alongside this material so you can reference the plan as you need to, and reference the pipe chart as required.

FIGURE 1

Maximum Capacity of Pipe in Cubic Feet of Natural Gas per Hour
(Based upon a Pressure Drop of 0.3 Inch Water Column
and 0.6 Specific Gravity Gas)

Length in Feet	Nominal Iron Pipe Size, Inches								
	1/2	3/4	1	1 1/4	1 1/2	2	2 1/2	3	4
10	132	278	520	1,050	1,600	3,050	4,800	8,500	17,500
20	92	190	350	730	1,100	2,100	3,300	5,900	12,000
30	73	152	285	590	890	1,650	2,700	4,700	9,700
40	63	130	245	500	760	1,450	2,300	4,100	8,300
50	56	115	215	440	670	1,270	2,000	3,600	7,400
60	50	105	195	400	610	1,150	1,850	3,250	6,800
70	46	96	180	370	560	1,050	1,700	3,000	6,200
80	43	90	170	350	530	990	1,600	2,800	5,800
90	40	84	160	320	490	930	1,500	2,600	5,400
100	38	79	150	305	460	870	1,400	2,500	5,100
125	34	72	130	275	410	780	1,250	2,200	4,500
150	31	64	120	250	380	710	1,130	2,000	4,100
175	28	59	110	225	350	650	1,050	1,850	3,800
200	26	55	100	210	320	610	980	1,700	3,500

ASSIGNMENT SHEET #3

Procedure

1. Assume that the gas to be used has a specific gravity of 0.65 and a heating value of 1,000 Btu per cubic feet.
2. Start by dividing the Btuh rating for each output by the Btu rating of the gas supply to get the cfh (cubic feet per hour) each appliance will consume when operating.

Example: The water heater at Outlet A has a rating of 30,000 Btu per hour, so 30,000 divided by 1,000, the Btu rating of the gas supply, would be 30 cfh.

3. Consult your system plan as needed to complete cfh computation for all outlets:
 - a) Outlet B = _____cfh.
 - b) Outlet C = _____cfh.
 - c) Outlet D = _____cfh.
4. Size the total system by starting with the outlet that has the largest cfh. In this case, that will be _____.
5. Go to the gas meter and enter the number of feet of pipe required to reach from the meter to the outlet with the largest cfh. In this case that will be _____ feet.
6. Now, go to the length in feet column which is _____, and move to the right until you find the pipe size that will accommodate the length in feet and the cfh.
7. Enter the size pipe required for Section 3 _____.
8. Go to the outlet that requires the next highest cfh. In this case, that is _____.
9. Enter the distance in feet from the intersection with Section 3 to the outlet at section 2 _____.
10. Now, go to the length in feet column, and move to the right until you find the pipe size that will accommodate the length in feet and the cfh. In this case, the pipe size for section 2 will be _____.

(NOTE: Move to the highest figure required in the length in feet column.)

11. Go to the outlet that requires the next highest cfh. In this case, that is _____, and the pipe size required for that section is _____.
12. Go to the outlet that requires the least cfh. In this case, that is _____, and the pipe size required for that section is _____.

ASSIGNMENT SHEET #3

- Have your instructor check your calculations.

FIGURE 2

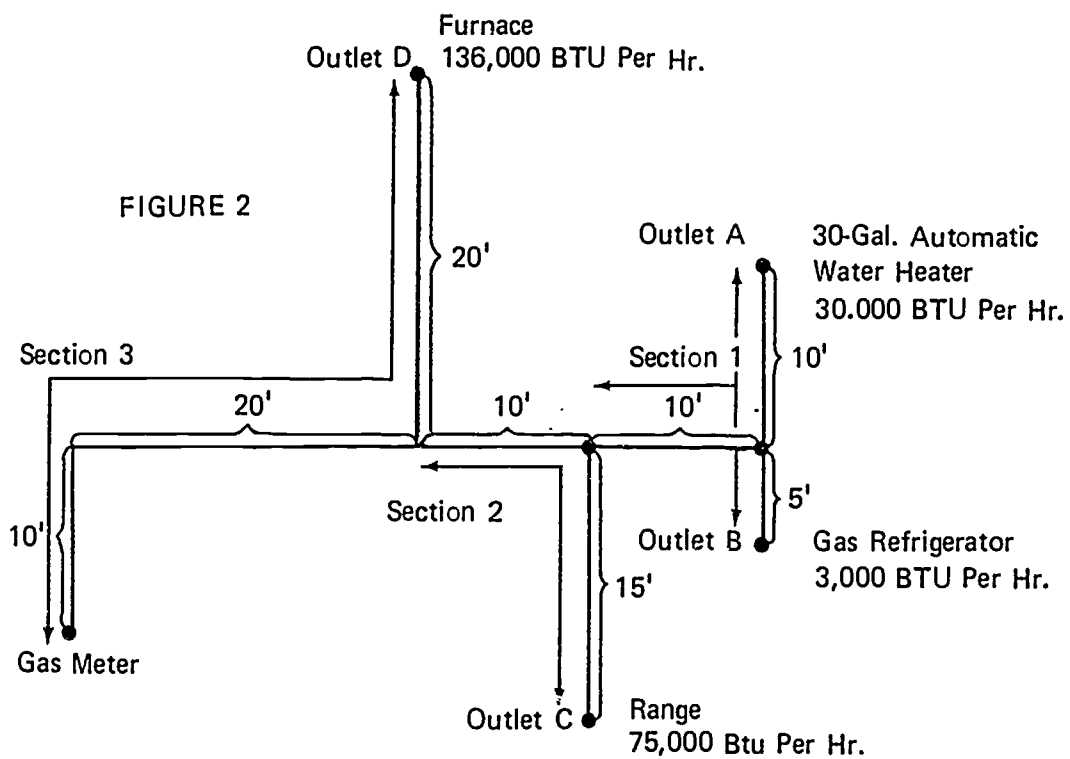

STANDARD GAS-FIRED FURNACES
UNIT IX

ANSWERS TO ASSIGNMENT SHEETS

Assignment Sheet #1

1.

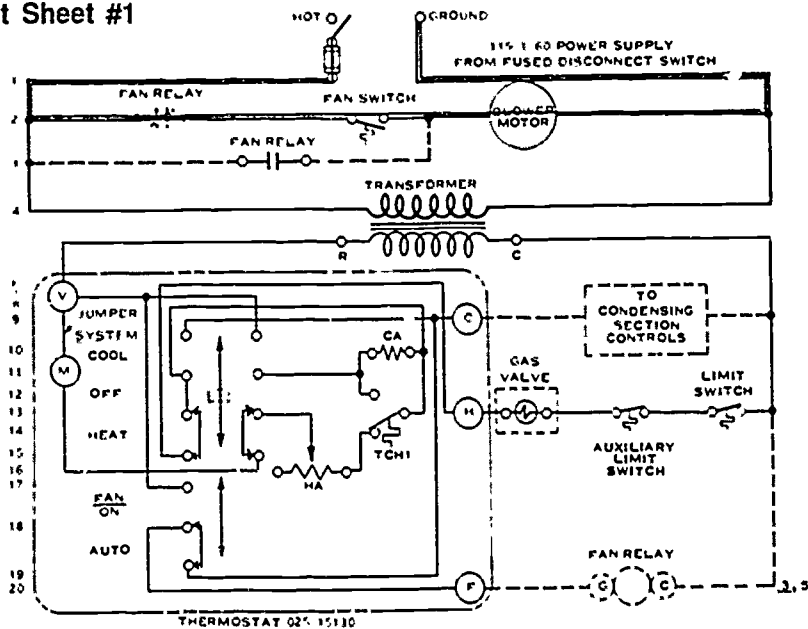

2.

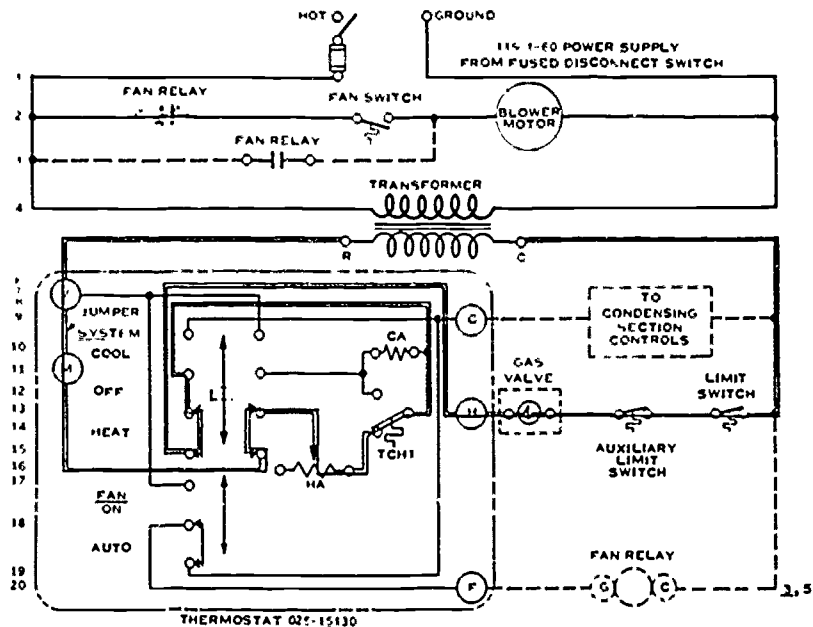

ANSWERS TO ASSIGNMENT SHEETS

Assignment Sheet #2

1.

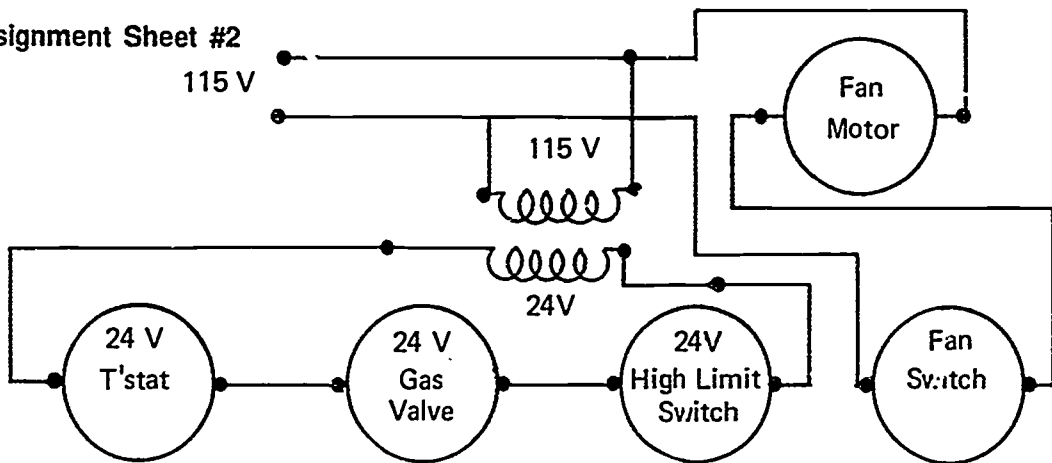

2.

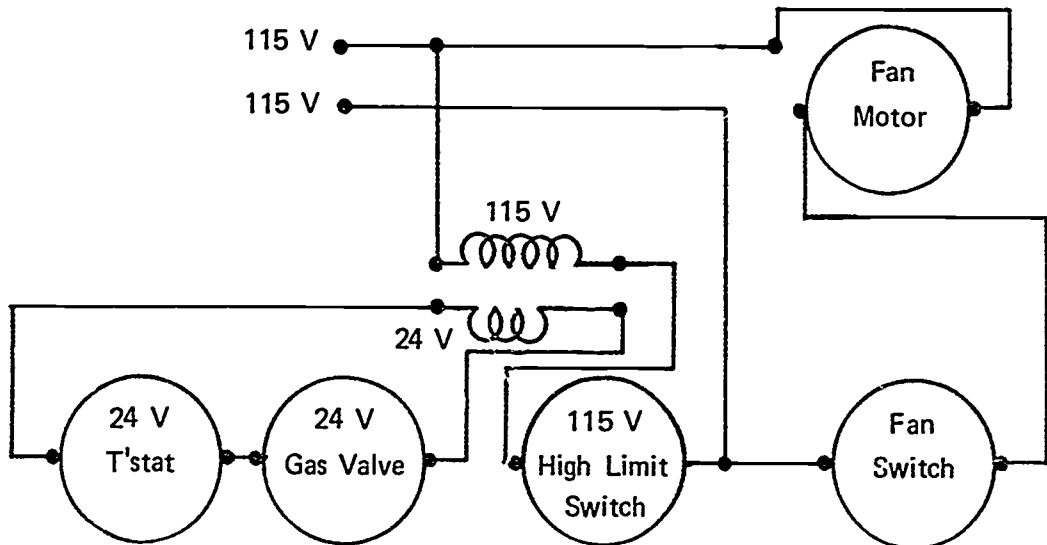

3.

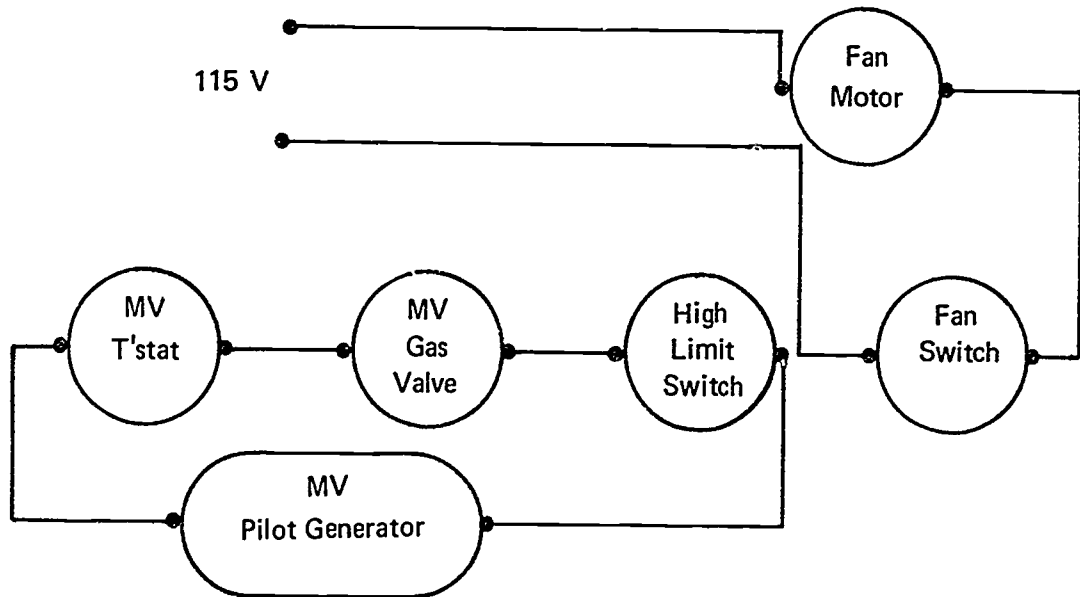

ANSWERS TO ASSIGNMENT SHEETS

Assignment Sheet #3

3.
 - a) 30 c/in
 - b) 3 cfh
 - c) 75 cfh
 - d) 136 cfh
4. Outlet D
5. 50 feet
6. 50
7. 1 inch
8. Outlet C
9. 25 feet
10. 3/4 inch
11. Outlet A, 1/2 inch
12. Outlet B, 1/2 inch

**STANDARD GAS-FIRED FURNACES
UNIT IX****JOB SHEET #1 — INSTALL A GAS FURNACE**

- A. Tools and equipment
1. Service technician's tool pouch/box
 2. Aviation snips
 3. Electric drill and bits
 4. Hammer
 5. Screwdrivers
 6. Pocket level
 7. Furnace selected by instructor
 8. Wall thermostat
 9. Safety glasses
- B. Procedure
1. Put on safety glasses.
 2. Remove crating.
 3. Read manufacturer's installation instructions.
 4. Set furnace in location.
 5. Adapt and fasten plenum to top of furnace cabinet.
 6. Adapt and fasten return air ducts to furnace cabinet.
 7. Install gas piping from gas cock to the gas valve in the furnace.
 8. Connect low voltage thermostat wires to proper terminals in the furnace.
 9. Mount wall thermostat making sure it is level.
 10. Connect wires to correct terminals in the thermostat.
 11. Adjust heat anticipator to correct setting given by the manufacturer; if not given, adjust setting to amp draw listed on the gas valve.
 12. Connect power supply cord to the proper terminals on furnace electrical system.

JOB SHEET #1

13. Adapt and connect vent piping.
14. Provide proper combustion air supply.
15. Turn gas cock to the "on" position.
16. Loosen fitting to purge air from the lines and re-tighten.
17. Check pipe fittings using soap bubbles to assure there are no leaks.
- Have your instructor check your installation.
18. Clean the work area and return tools to the proper place.

**STANDARD GAS-FIRED FURNACES
UNIT IX**

JOB SHEET #2 — START AND ADJUST A GAS FURNACE

A. Tools and equipment

1. Service technician's tool pouch/box
2. Volt-ohm-ammeter
3. Manometer
4. Combustion test kit
5. Thermometers (2)
6. Furnace selected by instructor
7. Safety glasses

B. Procedure

1. Visually inspect work area to insure safety, and put on safety glasses.
2. Turn gas cock to the "off" position.
3. Install manometer on the manifold or on the gas valve test port.
4. Turn gas cock to the "on" position.
5. Light the pilot and observe being certain that pilot flame is burning properly and thermocouple is properly positioned in the pilot flame.
6. Set thermostat to "call for heat."
7. Measure actual amp draw and set heat anticipator.
8. Observe the manifold gas pressure and adjust to the manufacturer's setting if necessary.
9. Light a match and hold it near the dilution air intake area of the draft hood to determine that vent is working properly; flame should be drawn into the draft hood.
10. Use combustion test kit for sampling flue products, following the directions carefully.
11. Insert a thermometer in the supply and return ducts to determine the temperature rise; subtract return reading from the supply reading.
12. Check the furnace ratings plate to determine if the temperature rise is within the specified range.

JOB SHEET #2

13. Use ammeter to check blower motor load to see that the current draw is not more than nameplate shows.

(NOTE: Blower compartment access door must be in place for proper current reading.)

14. Disconnect lead to blower motor or block the return air inlet to check that the high limit control is operative.
15. Extinguish the pilot flame, allowing the thermocouple to cool to check that the gas valve will not operate in the absence of a pilot flame.
16. Turn the thermostat to the "off" position.
17. Remove thermometers from the ducts.
18. Turn gas cock to the "off" position.
19. Remove the manometer from manifold.
- Have your instructor check your work.
20. Clean work area and return tools to the proper place.

**STANDARD GAS-FIRED FURNACES
UNIT IX****JOB SHEET #3 — DISASSEMBLE, INSPECT, AND REASSEMBLE
AN UPFLOW GAS FURNACE**

- A. Tools and equipment:
1. Service technician's tool pouch/box
 2. Flash light
 3. Mirror
 4. Oil can
 5. Lubricant per manufacturer's specifications
 6. Manometer
 7. Combustion test kit
 8. Upflow gas furnace as selected by instructor
 9. Safety glasses
- B. Procedure:
1. Inspect work area to insure safety, and put on safety glasses.
 2. Disconnect power source.
 3. Close gas cock and disconnect gas piping.
 4. Remove vent piping.
 5. Remove blower plenum door or panel.
 6. Remove holding screws on the blower and motor and slide the blower assembly out.
 7. Remove gas manifold.
 8. Remove burners from compartments.
 9. Remove all screws from heat exchanger and slide the exchanger out from the covering chamber.
 10. Inspect heat exchanger with a flashlight and mirror to determine whether or not there are any cracks.

(NOTE: If cracks appear in a heat exchanger, it should be replaced; for this job sheet it is assumed the heat exchanger has no cracks.)

JOB SHEET #3

11. Clean heat exchanger before reassembling.
12. Clean motor and blower assembly.
13. Lubricate motor and blower if required.
14. Reassemble components by repeating disassembly steps in reverse.
15. Set thermostat to call for heat and run furnace through a complete cycle.
16. Check and adjust gas and air mixture until it produces a blue flame.
17. Install manometer on manifold and check and adjust gas pressure.
18. Use combustion test kit for sampling flue products, following directions carefully.
19. Determine that safety devices are working properly.
- Have your instructor check your work.
20. Clean work area and return tools to the proper place.

STANDARD GAS-FIRED FURNACES UNIT IX

JOB SHEET #4 — PERFORM MAINTENANCE ON A GAS FURNACE

A. Tools and equipment:

1. Service technician's tool pouch/box
2. Small mirror with swivel attachment on 12" handle
3. Flashlight
4. Dial thermometer
5. Industrial vacuum cleaner
6. Gas furnace as selected by instructor
7. Safety glasses

B. Procedure:

1. Disconnect furnace power source, inspect work area, and put on safety glasses.
2. Clean and lubricate blower and motor bearings.

(NOTE: Some motors and bearings are sealed and do not require field lubrication.)

3. Check belt for slipping or wear if it is a belt-type blower.
4. Inspect filters and clean if necessary.
5. Remove burners.

(CAUTION: If it is necessary to remove the burner assembly in order to remove the burners, it is important to close the gas cock on the gas meter side on the union.)

6. Inspect bottom of entire heat exchanger for cracks.

(NOTE: Sometimes the blower has to be removed in order to see all of the heat exchanger.)

7. Tap rust and soot out of burners.
8. Remove any accumulation of rust and soot from the bottom of heat exchanger.

(NOTE: A service technician should have an industrial type vacuum cleaner available to remove heavy accumulations of rust and soot.)

JOB SHEET #4

10. Replace burners and other components removed to inspect heat exchanger.
11. Return gas cock to "ON" position.
12. Relight pilot and observe pilot flame.
13. Reconnect power source to furnace.
14. Allow pilot safety to reset.
15. Turn off gas to pilot and check to see if pilot safety locks out main gas valve.
16. Relight pilot.
17. Set room thermostat to heat and raise temperature to call for heat.
18. Observe action of gas valve.
19. Observe height, color, and evenness of flame.
20. Adjust burner air shutters to produce blue flame with little or no yellow flame.
21. Remove a sheet metal screw in the vicinity of the limit switch and insert dial thermometer.

(CAUTION: Be careful not to mistake a limit switch screw for a sheet metal screw, and be especially aware of the danger of electrical shock while you're working with an energized system.)
22. Continue observing flames until blower energizes, then note temperature of thermometer.
23. Examine flames for any change in motion while blower is operating.

(NOTE: Hairline cracks in heat exchangers frequently open up under operating temperatures and escaping air will move or blow the flames.)
24. Open furnace disconnect switch.
25. Remove a blower motor wire from fan switch and insulate the bare wire.
26. Close the furnace disconnect switch and fire the burners.
27. Observe, with blower stopped, the temperature of the thermometer as the furnace begins to overheat.
28. Note the action of the high limit switch.

(NOTE: The gas valve should close before the furnace bonnet temperature reaches approximately 200°F.)
29. Open furnace disconnect switch and reconnect the blower.

JOB SHEET #4

30. Close furnace disconnect.
31. Observe temperature at which the fan starts.
32. Set thermostat to a setting lower than room temperature.
33. Observe temperature at which the fan stops.
34. Remove thermometer.
35. Return thermostat to proper setting.
- Have your instructor check your work.
36. Clean up tools and area and put tools away.

STANDARD GAS-FIRED FURNACES UNIT IX

JOB SHEET #5 — TROUBLESHOOT A GAS FURNACE ON A "NO HEAT" COMPLAINT

- A. Tools and equipment
1. Service technician's tool pouch/box
 2. Volt-ohm-ammeter
 3. Millivolt meter
 4. Gas furnace as selected by instructor
 5. Safety glasses
- B. Procedure
1. Inspect work area for safety and put on safety glasses.
 2. Check power source with voltmeter.
 3. Set room thermostat above room temperature.
 4. Check output of 24 volt transformer for voltage.
 5. Check 115 volt circuit from panel through disconnect to transformer if the transformer is dead.
 - a. Later model furnaces have a door switch that interrupts the circuit if the blower access panel is not in place.
 - b. Some low voltage transformers are fused with low amperage (3.2A) through the secondary circuit.
 6. Check proper adjustment and alignment of pilot flame.
 7. Identify type of gas valve.

(NOTE: If gas valve does not open, then the thermocouple is probably bad.)
 8. Check thermocouple with millivolt meter.

(NOTE: Under load, the reading should be 7 to 15 mV, and open, the reading should be 25 to 30 mV.)
 9. Disconnect 24 volt wires from gas valve and test for voltage.

JOB SHEET #5

10. Establish 24 volts available at valve, then if valve does not open it is bad.
(NOTE: A shorted gas valve will usually burn up a transformer or anticipator, and remember that some slow opening and closing gas valves take up to 20 seconds to open after applying 24 volts.)
11. Establish 24 volts not present at the gas valve, then check continuity through 24 volt circuit.
(NOTE: A few limit switches have to be manually reset after tripping.)
12. Check for open high limit switch.
(NOTE: An open high limit switch usually results from insufficient air volume through the furnace, and this may result from a clogged filter, a bad fan belt, a bad blower motor, or too many outlets closed.)
13. Restore all high and low voltage continuity and ready all controls for operation.
14. Fire the furnace and check the thermocouple.
15. Check the fan switch and operating temperatures.
16. Check the limit switch temperature.
(NOTE: Do not rotate the dial of a fan or limit switch.)
- Have your instructor check your work.
17. Clean up tools and area and put tools away.

**STANDARD GAS-FIRED FURNACES
UNIT IX****JOB SHEET #6 — INSTALL A RETROFIT PACKAGE TO REPLACE
A STANDING PILOT WITH A CYCLING PILOT****A. Tools and equipment**

1. Service technician's tool pouch/box
2. Volt-ohm-ammeter
3. White-Rodgers 21D18 retrofit package or equivalent
4. Gas furnace with standing pilot as selected by instructor

(NOTE: The procedures and illustrations in this job sheet are reprinted with the permission of the White-Rodgers Division, Emerson Electric Co. The procedures and components used are designed to reflect the essential elements in converting a standing pilot light into an energy saving intermittent ignition system and no endorsement of product or procedure is intended.)

5. Safety glasses**B. Procedure**

1. Check Retro-Fit package to make sure flame sensor, gas valve, electrode assembly, and relight control are included. (Figure 1)

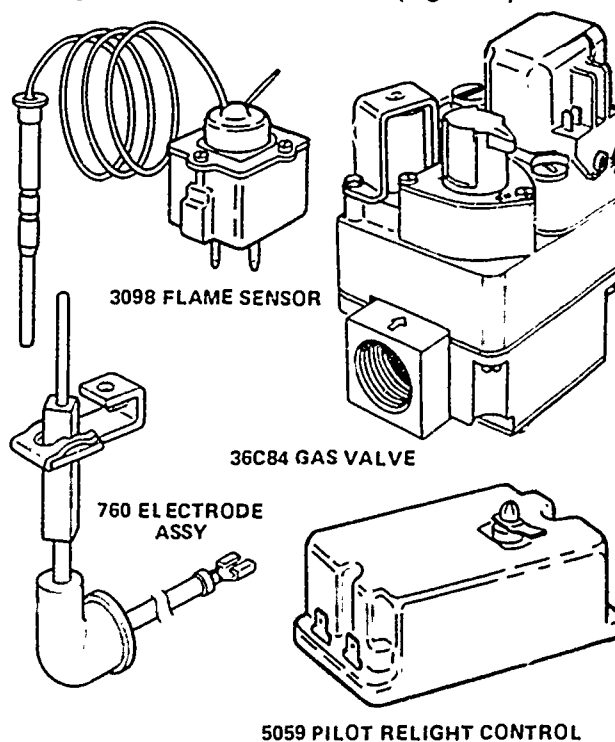
FIGURE 1

JOB SHEET #6

2. Complete the following checks before shutting off gas and power:
 - a. Cycle system to insure operating and limit controls are functioning properly.
 - b. Check for other possible furnace/boiler malfunctions; ie., cracked heat exchanger, blocked flue, cracked boiler sections, and evidence of leaks.
 - c. Check incoming supply voltage and 24 volt transformer output. Be sure transformer capacity is adequate. This control system requires 15 VA for proper operation.
 - d. Observe pilot flame pattern to determine best location for ignition electrode placement.
 - e. Visually check size and length requirements of present control system to insure Retro-fit components will fit in the space provided.
3. Turn off gas and electrical power to the system, and put on safety glasses.
4. Remove existing gas valve and thermocouple and any other components used in existing system but not required for conversion application; i.e., on a single function control system, remove the gas solenoid, pilot stat., and pressure regulator.
5. Insert bulb of Mercury Flame Sensor into pilot burner in place of thermocouple. (Figure 2)

FIGURE 2

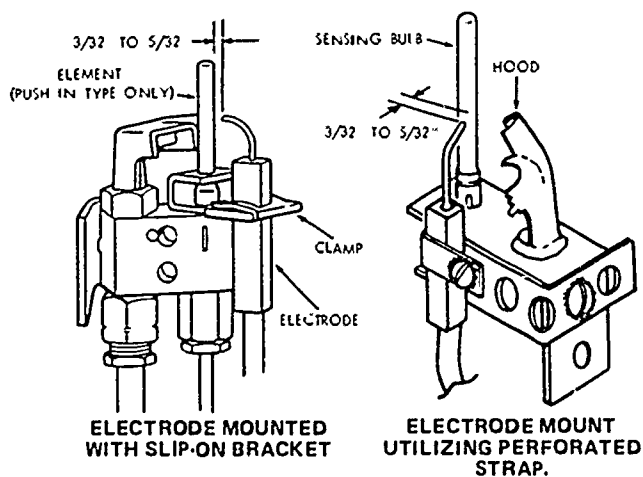

JOB SHEET #6

6. Secure Flame Sensor using the pilot burner adapters supplied with Retro-Fit package. (Figure 3)

(NOTE: Check Figures 10 through 16 for demonstrations of typical applications.)

FIGURE 3

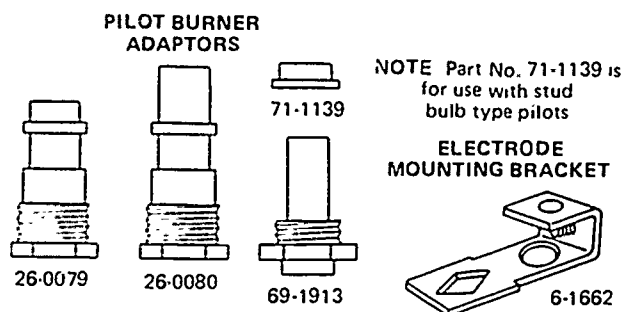

7. Double check pilot burner for correct placement.

(CAUTION: UNDER NO CIRCUMSTANCES should the existing pilot burner be relocated, or an existing factory-installed shield be altered; if pilot burner replacement is necessary, use only a pilot burner approved for the appliance; if the pilot or main burner have to be removed to properly locate ignition electrode, be sure they are replaced in the **EXACT** location of factory installation.)

8. Locate 760 series electrode on pilot burner as shown in Figure 2.
9. Slip mounting bracket over flame sensor bulb to form a $3/32$ " to $5/32$ " spark gap and be sure spark gap is in pilot gas stream.
10. Cut off excess electrode if it is too long.

(CAUTION: Be sure rod is **NOT** close to appliance chassis to prevent electrode from arcing to ground; if electrode cannot be mounted with the slip-on mounting bracket due to pilot burner placement, remove ceramic from slip-on bracket and use a brass perforated strap and "U" clamp to mount electrode assembly as shown in Figure 2.)

11. Double check assembly; flame must **NOT IMPINGE** on ceramic insulator or the ceramic will be damaged:
- a. When positioning electrode, spark should jump through pilot gas stream to Flame Sensor bulb. Electrode rod must remain in pilot flame after gas has been ignited. (Electrode rod is part of 5059 Relight control flame detection circuitry.)
 - b. When adjusting/bending electrode rod, use two pair of pliers to prevent bending or twisting at the point electrode enters ceramic insulator.

JOB SHEET #6

12. Mount 36C84 gas valve on supply pipe; valve may be mounted in any position, except upside down; direction of gas flow is indicated by arrow stamped on pipe boss. (Figure 4)
- Where possible, new, properly chamfered and clean pipe should be used. If old pipe is used, be sure it is clean and free of rust and scale.
 - Be sure threaded end of pipe is free of burrs and chips. Sparingly apply approved pipe dope to the first three or four pipe threads. Applying pipe dope to the first three or four threads will prevent chips from passing onto internal valve parts since pipe dope will collect and retain metal chips that are formed as the pipe is threaded into valve body.

FIGURE 4

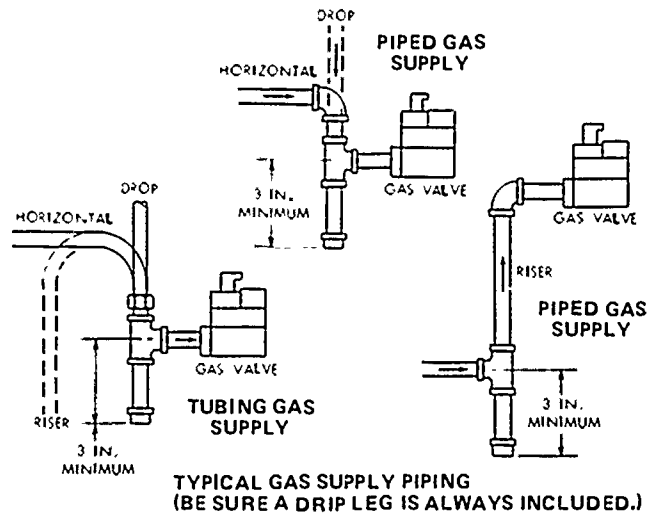

13. Attach pilot tubing to gas valve. Install fitting into pilot gas tapping, turning until finger-tight; insert clean deburred tubing all the way through the fitting; holding the tubing securely, slowly tighten fitting until a slight "give" is felt, then tighten $1\frac{1}{2}$ additional turns.
14. Mount the 5059 Pilot Relight control in an area on the appliance where it will not be affected by roll out flame, flame heat, or radiant heat; maximum ambient-temperature is 150°F.
- Be sure metal to metal contact is made between mounting hole stand-offs on relight control and mounting surface.

JOB SHEET #6

- b. Connect high voltage lead to terminal on top of Relight control, after feeding lead through angled insulation boot; press boot over connection. Avoid excessive strain on ignition cable to prevent cable from being pulled out of ceramic (the ignition cable is held in the ceramic by a push-on connector); see Figure 5.

FIGURE 5

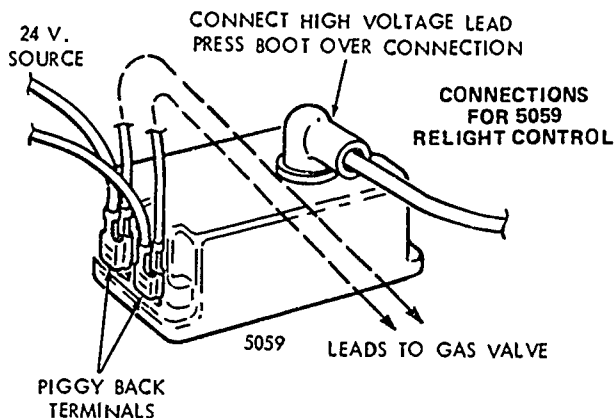

- 15. Attach leads from terminals "C" and "L" on the gas valve using 1/4" female spade connectors and route these leads to the 5059 Relight Control; attach 1/4" piggy-back spade terminals to the leads and attach them to the male spade connections to the Relight control; see Figures 5 and 6.

FIGURE 6

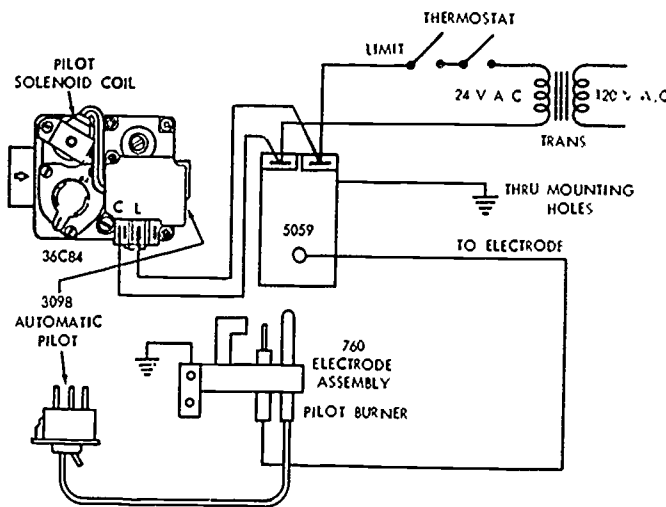

TYPICAL LOW VOLTAGE WIRING

JOB SHEET #6

16. Modify procedure if replacing a 24-volt gas valve; attach wires previously connected to OLD gas valve to the piggy-back terminals on the 5059 Relight control; if replacing other control configurations, refer to Figures 6 through 9 for typical wiring.

FIGURE 7

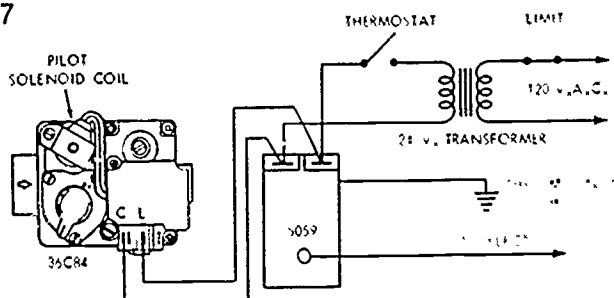
TYPICAL WIRING FOR LOW VOLTAGE
THERMOSTAT AND LINE VOLTAGE LIMIT

17. Check to be sure the limit control IS NOT accidentally wired OUT of the CIRCUIT.
18. Inspect all old wiring for damage, loose connections, etc; secure all wiring to chassis or piping with electrical/friction tape or plastic wire-wraps.
19. Carefully extend capillary coil from pilot burner to prevent kinks or other damage; capillary should be stretched only far enough to reach gas valve; excess capillary should remain coiled to prevent damage.
20. Use soap solution to leak-check piping to gas valve.
21. Adjust heat anticipator on room thermostat for .6 amps current draw.
- (CAUTION: Do not jumper or accidentally short terminals on 5059 Relight control: room thermostat heat anticipator could BURN OUT!)
22. Turn on power to appliance. Adjust room thermostat to call for heat.
23. Check 5059 Relight control, it should begin sparking.
24. Make sure sparking occurs between ignition electrode and Mercury Flame sensor or pilot hood, in the middle of the gas stream; the spark gap must be 3/32" to 5/32"; if electrode placement is not correct, disconnect power, and re-position electrode.
25. Turn gas cock on valve to ON position.
26. Turn on power to appliance to energize system; two to five minutes will be required to bleed air through the valve and pilot line; once gas is present at the pilot, leak-check the pilot line with soap solution.

401

JOB SHEET #6

27. Check to see that sparks from the Relight control stop as soon as pilot flame is established; if sparking does not stop, make sure ignition electrode is in pilot flame and metal standoffs on 5059 Relight control are grounded.
 28. Allow about 45 seconds for pilot flame to heat Mercury Flame sensor; Flame sensor will then switch main valve ON and main burner will ignite.
 29. Use soap solution to leak-check the piping to the main burner.
 30. Cycle the system a number of times to insure smooth ignition and proper operation.
 31. Place new "LIGHTING INSTRUCTIONS" over existing instructions; clean area to accept adhesive backed label; remove protective backing and attach label.
- Have your instructor check your work.
32. Clean up area and return tools.

FIGURE 8

TYPICAL WIRING FOR LINE VOLTAGE
THERMOSTAT AND LIMIT

FIGURE 9



TYPICAL BOILER CONTROL WIRING

JOB SHEET #6

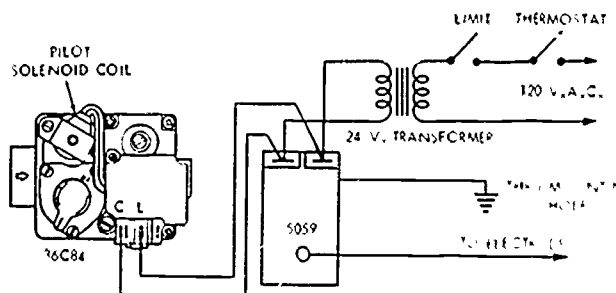
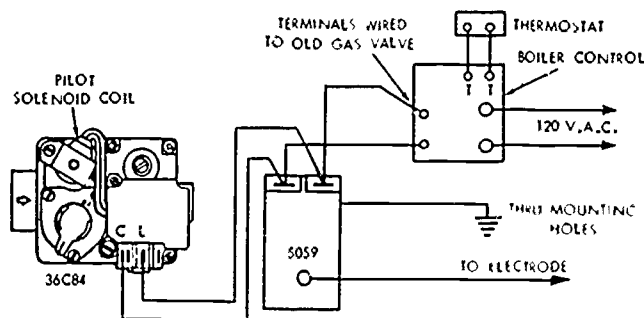
Typical Pilot Burner Applications

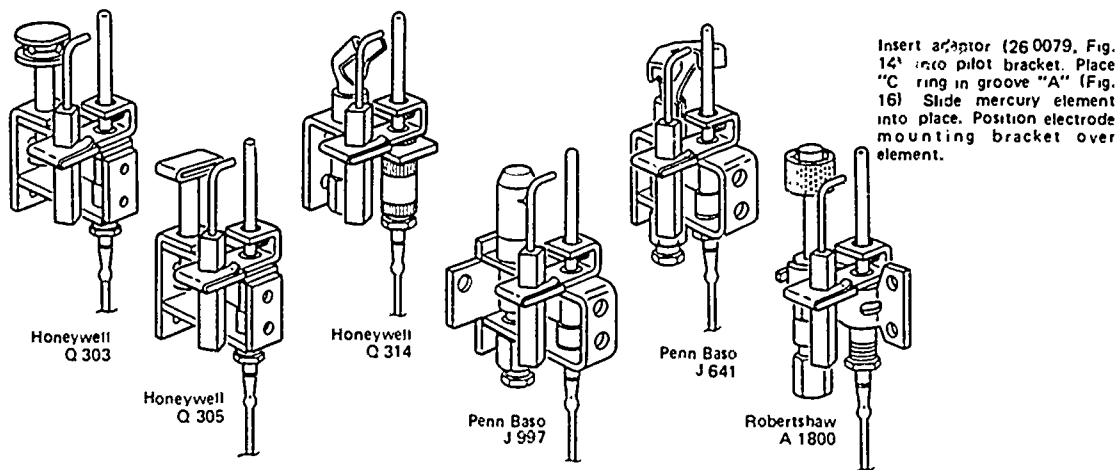

FIGURE 10

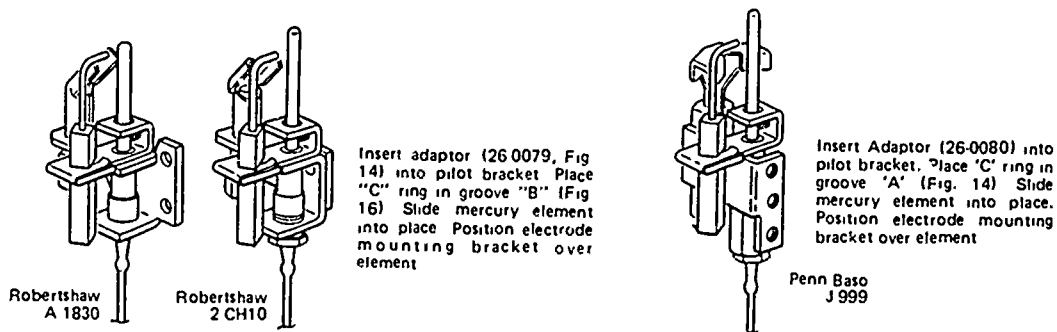

FIGURE 11

FIGURE 12

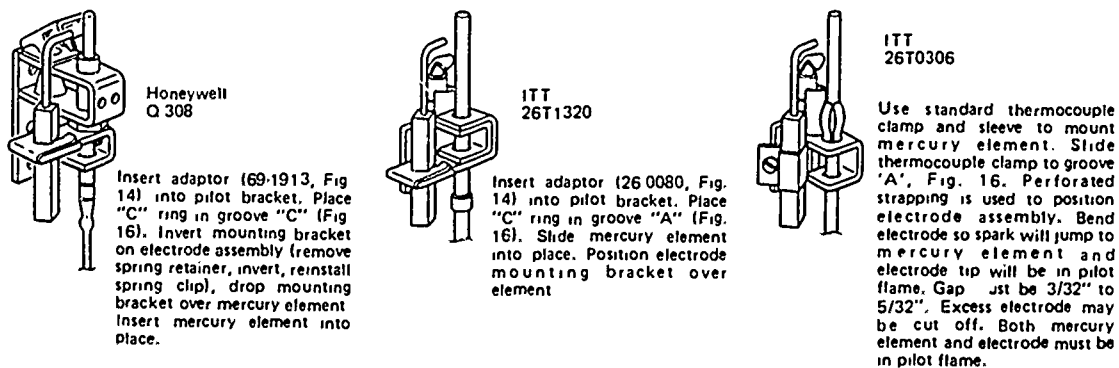

FIGURE 13

JOB SHEET #6

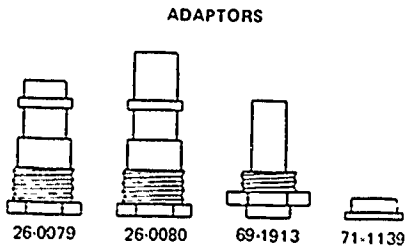

FIGURE 14

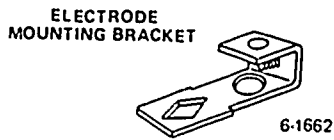

FIGURE 15

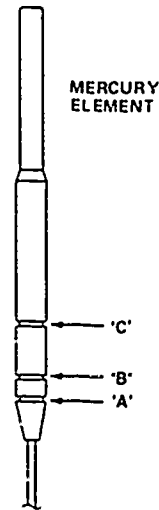

FIGURE 16

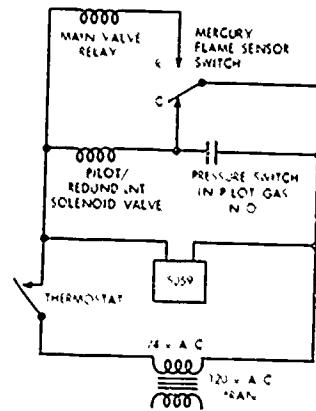

FIGURE 18

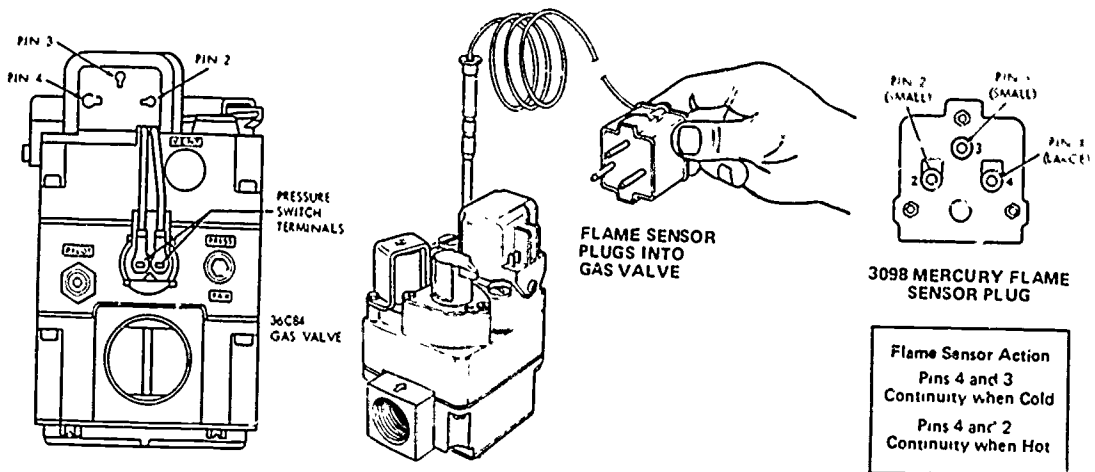

FIGURE 17

**STANDARD GAS-FIRED FURNACES
UNIT IX**

**PRACTICAL TEST #1
JOB SHEET #1 — INSTALL A GAS FURNACE**

Student's name _____ Date _____

Evaluator's name _____ Attempt no. _____

Student instructions: When you are ready to perform this task, ask your instructor to observe the procedure and complete this form. All items listed under "Process Evaluation" must receive a "yes" for you to receive an overall performance evaluation.

PROCESS EVALUATION

(EVALUATOR NOTE: Place a check mark in the "Yes" or "No" blanks to designate whether or not the student has satisfactorily achieved each step in this procedure. If the student is unable to achieve this competency, have the student review the materials and try again.)

The student:	YES	NO
1. Set furnace properly.	<input type="checkbox"/>	<input type="checkbox"/>
2. Fastened plenum to cabinet and air ducts.	<input type="checkbox"/>	<input type="checkbox"/>
3. Installed gas piping to gas valve.	<input type="checkbox"/>	<input type="checkbox"/>
4. Connected low voltage thermostat wires.	<input type="checkbox"/>	<input type="checkbox"/>
5. Mounted and wired thermostat.	<input type="checkbox"/>	<input type="checkbox"/>
6. Adjusted heat anticipator.	<input type="checkbox"/>	<input type="checkbox"/>
7. Connected furnace electrical system.	<input type="checkbox"/>	<input type="checkbox"/>
8. Connected vent piping and combustion air.	<input type="checkbox"/>	<input type="checkbox"/>
9. Purged air from gas lines.	<input type="checkbox"/>	<input type="checkbox"/>
10. Checked for gas leaks.	<input type="checkbox"/>	<input type="checkbox"/>

Evaluator's comments: _____

JOB SHEET #1 PRACTICAL TEST

PRODUCT EVALUATION

(EVALUATOR NOTE: Rate the student on the following criteria by circling the appropriate numbers. Each item must be rated at least a "3" for mastery to be demonstrated. (See performance evaluation key below.) If the student is unable to demonstrate mastery, student materials should be reviewed and another test procedure must be submitted for evaluation.)

 Criteria:

Furnace setup	4	3	2	1
Gas piping hookups	4	3	2	1
Electrical hookups and thermostat	4	3	2	1
Venting and combustion air	4	3	2	1

 EVALUATOR'S COMMENTS: _____

PERFORMANCE EVALUATION KEY
4 — Skilled — Can perform job with no additional training. 3 — Moderately skilled — Has performed job during training program; limited additional training may be required. 2 — Limited skill — Has performed job during training program; additional training is required to develop skill. 1 — Unskilled — Is familiar with process, but is unable to perform job.

(EVALUATOR NOTE: If an average score is needed to coincide with a competency profile, total the designated points in "Product Evaluation" and divide by the total number of criteria.)

**STANDARD GAS-FIRED FURNACES
UNIT IX**

**PRACTICAL TEST #2
JOB SHEET #2 — START AND ADJUST A GAS FURNACE**

Student's name _____ Date _____

Evaluator's name _____ Attempt no. _____

Student instructions: When you are ready to perform this task, ask your instructor to observe the procedure and complete this form. All items listed under "Process Evaluation" must receive a "yes" for you to receive an overall performance evaluation.

PROCESS EVALUATION

(EVALUATOR NOTE: Place a check mark in the "Yes" or "No" blanks to designate whether or not the student has satisfactorily achieved each step in this procedure. If the student is unable to achieve this competency, have the student review the materials and try again.)

The student:	YES	NO
1. Safely installed manometer.	<input type="checkbox"/>	<input type="checkbox"/>
2. Observed and adjusted manifold gas pressure.	<input type="checkbox"/>	<input type="checkbox"/>
3. Verified proper venting.	<input type="checkbox"/>	<input type="checkbox"/>
4. Sampled flue products with combustion test kit.	<input type="checkbox"/>	<input type="checkbox"/>
5. Verified proper temperature rise.	<input type="checkbox"/>	<input type="checkbox"/>
6. Checked blower motor load with ammeter.	<input type="checkbox"/>	<input type="checkbox"/>
7. Verified high limit load protection.	<input type="checkbox"/>	<input type="checkbox"/>
8. Verified gas valve shutoff when pilot was extinguished.	<input type="checkbox"/>	<input type="checkbox"/>

Evaluator's comments: _____

JOB SHEET #2 PRACTICAL TEST

PRODUCT EVALUATION

(EVALUATOR NOTE: Rate the student on the following criteria by circling the appropriate numbers. Each item must be rated at least a "3" for mastery to be demonstrated. (See performance evaluation key below.) If the student is unable to demonstrate mastery, student materials should be reviewed and another test procedure must be submitted for evaluation.)

Criteria:

Manometer use	4	3	2	1
Combustion test kit use	4	3	2	1
Temperature rise and high limit verification	4	3	2	1
Gas valve shutoff verification	4	3	2	1

EVALUATOR'S COMMENTS: _____

PERFORMANCE EVALUATION KEY

- 4 — **Skilled** — Can perform job with no additional training.
- 3 — **Moderately skilled** — Has performed job during training program; limited additional training may be required.
- 2 — **Limited skill** — Has performed job during training program; additional training is required to develop skill.
- 1 — **Unskilled** — Is familiar with process, but is unable to perform job.

(EVALUATOR NOTE: If an average score is needed to coincide with a competency profile, total the designated points in "Product Evaluation" and divide by the total number of criteria.)

**STANDARD GAS-FIRED FURNACES
UNIT IX**

**PRACTICAL TEST #3
JOB SHEET #3 — DISASSEMBLE, INSPECT, AND
REASSEMBLE AN UPFLOW GAS FURNACE**

Student's name _____ Date _____

Evaluator's name _____ Attempt no. _____

Student instructions: When you are ready to perform this task, ask your instructor to observe the procedure and complete this form. All items listed under "Process Evaluation" must receive a "yes" for you to receive an overall performance evaluation.

PROCESS EVALUATION

(EVALUATOR NOTE: Place a check mark in the "Yes" or "No" blanks to designate whether or not the student has satisfactorily achieved each step in this procedure. If the student is unable to achieve this competency, have the student review the materials and try again.)

The student:	YES	NO
1. Disassembled furnace for inspection.	<input type="checkbox"/>	<input type="checkbox"/>
2. Checked heat exchanger for cracks.	<input type="checkbox"/>	<input type="checkbox"/>
3. Cleaned heat exchanger.	<input type="checkbox"/>	<input type="checkbox"/>
4. Cleaned motor and blower assembly.	<input type="checkbox"/>	<input type="checkbox"/>
5. Reassembled components in proper order.	<input type="checkbox"/>	<input type="checkbox"/>
6. Ran furnace through a complete cycle.	<input type="checkbox"/>	<input type="checkbox"/>
7. Adjusted pilot flame properly.	<input type="checkbox"/>	<input type="checkbox"/>
8. Checked and adjusted gas pressure.	<input type="checkbox"/>	<input type="checkbox"/>
9. Sampled flue products with combustion test kit.	<input type="checkbox"/>	<input type="checkbox"/>
10. Verified operation of all safety devices.	<input type="checkbox"/>	<input type="checkbox"/>

Evaluator's comments: _____

JOB SHEET #3 PRACTICAL TEST

PRODUCT EVALUATION

(EVALUATOR NOTE: Rate the student on the following criteria by circling the appropriate numbers. Each item must be rated at least a "3" for mastery to be demonstrated. (See performance evaluation key below.) If the student is unable to demonstrate mastery, student materials should be reviewed and another test procedure must be submitted for evaluation.)

Criteria:

Furnace disassembly	4	3	2	1
Heat exchanger inspection and cleaning	4	3	2	1
Furnace reassembly	4	3	2	1
System inspection and adjustment	4	3	2	1

EVALUATOR'S COMMENTS: _____

PERFORMANCE EVALUATION KEY

- 4 — **Skilled** — Can perform job with no additional training.
- 3 — **Moderately skilled** — Has performed job during training program; limited additional training may be required.
- 2 — **Limited skill** — Has performed job during training program; additional training is required to develop skill.
- 1 — **Unskilled** — Is familiar with process, but is unable to perform job.

(EVALUATOR NOTE: If an average score is needed to coincide with a competency profile, total the designated points in "Product Evaluation" and divide by the total number of criteria.)

**STANDARD GAS-FIRED FURNACES
UNIT IX**

**PRACTICAL TEST #4
JOB SHEET #4 — PERFORM MAINTENANCE ON A GAS FURNACE**

Student's name _____ Date _____

Evaluator's name _____ Attempt no. _____

Student instructions: When you are ready to perform this task, ask your instructor to observe the procedure and complete this form. All items listed under "Process Evaluation" must receive a "yes" for you to receive an overall performance evaluation.

PROCESS EVALUATION

(EVALUATOR NOTE: Place a check mark in the "Yes" or "No" blanks to designate whether or not the student has satisfactorily achieved each step in this procedure. If the student is unable to achieve this competency, have the student review the materials and try again.)

The student:	YES	NO
1. Cleaned and lubricated blower motor and bearings.	<input type="checkbox"/>	<input type="checkbox"/>
2. Cleaned burners and heat exchanger.	<input type="checkbox"/>	<input type="checkbox"/>
3. Inspected and cleaned pilot assembly.	<input type="checkbox"/>	<input type="checkbox"/>
4. Turned off pilot to verify gas valve safety shutoff.	<input type="checkbox"/>	<input type="checkbox"/>
5. Adjusted burner air shutters to produce blue flame.	<input type="checkbox"/>	<input type="checkbox"/>
6. Took operating temperature at high limit switch.	<input type="checkbox"/>	<input type="checkbox"/>
7. Used furnace disconnect to check furnace overheating and high limit switch operation.	<input type="checkbox"/>	<input type="checkbox"/>
8. Reconnected blower and completed system operation check.	<input type="checkbox"/>	<input type="checkbox"/>

Evaluator's comments: _____

JOB SHEET #4 PRACTICAL TEST

PRODUCT EVALUATION

(EVALUATOR NOTE: Rate the student on the following criteria by circling the appropriate numbers. Each item must be rated at least a "3" for mastery to be demonstrated. (See performance evaluation key below.) If the student is unable to demonstrate mastery, student materials should be reviewed and another test procedure must be submitted for evaluation.)

Criteria: _____

Basic equipment checks and cleaning	4	3	2	1
Gas valve shutoff verification	4	3	2	1
High limit switch verification	4	3	2	1
System operation verification	4	3	2	1

EVALUATOR'S COMMENTS: _____

PERFORMANCE EVALUATION KEY

- 4 — **Skilled** — Can perform job with no additional training.
- 3 — **Moderately skilled** — Has performed job during training program; limited additional training may be required.
- 2 — **Limited skill** — Has performed job during training program; additional training is required to develop skill.
- 1 — **Unskilled** — Is familiar with process, but is unable to perform job.

(EVALUATOR NOTE: If an average score is needed to coincide with a competency profile, total the designated points in "Product Evaluation" and divide by the total number of criteria.)

**STANDARD GAS-FIRED FURNACES
UNIT IX**

**PRACTICAL TEST #5
JOB SHEET #5 — TROUBLESHOOT A GAS FURNACE
ON A "NO HEAT" COMPLAINT**

Student's name _____ Date _____

Evaluator's name _____ Attempt no. _____

Student instructions: When you are ready to perform this task, ask your instructor to observe the procedure and complete this form. All items listed under "Process Evaluation" must receive a "yes" for you to receive an overall performance evaluation.

PROCESS EVALUATION

(EVALUATOR NOTE: Place a check mark in the "Yes" or "No" blanks to designate whether or not the student has satisfactorily achieved each step in this procedure. If the student is unable to achieve this competency, have the student review the materials and try again.)

The student:	YES	NO
1. Checked voltage of 24 volt transformer.	<input type="checkbox"/>	<input type="checkbox"/>
2. Checked and adjusted pilot flame.	<input type="checkbox"/>	<input type="checkbox"/>
3. Checked thermocouple with millivolt meter.	<input type="checkbox"/>	<input type="checkbox"/>
4. Checked gas valve to verify proper operation.	<input type="checkbox"/>	<input type="checkbox"/>
5. Checked for open high limit switch.	<input type="checkbox"/>	<input type="checkbox"/>
6. Restored all electrical continuity.	<input type="checkbox"/>	<input type="checkbox"/>
7. Fired furnace and made operational check.	<input type="checkbox"/>	<input type="checkbox"/>

Evaluator's comments: _____

JOB SHEET #5 PRACTICAL TEST

PRODUCT EVALUATION

(EVALUATOR NOTE: Rate the student on the following criteria by circling the appropriate numbers. Each item must be rated at least a "3" for mastery to be demonstrated. (See performance evaluation key below.) If the student is unable to demonstrate mastery, student materials should be reviewed and another test procedure must be submitted for evaluation.)

Criteria: _____

Electrical troubleshooting	4	3	2	1
Gas valve operation verification	4	3	2	1
Limit switch operation verification	4	3	2	1
Total system operation verification	4	3	2	1

EVALUATOR'S COMMENTS: _____

PERFORMANCE EVALUATION KEY

- 4 — **Skilled** — Can perform job with no additional training.
- 3 — **Moderately skilled** — Has performed job during training program; limited additional training may be required.
- 2 — **Limited skill** — Has performed job during training program; additional training is required to develop skill.
- 1 — **Unskilled** — Is familiar with process, but is unable to perform job.

(EVALUATOR NOTE: If an average score is needed to coincide with a competency profile, total the designated points in "Product Evaluation" and divide by the total number of criteria.)

**STANDARD GAS-FIRED FURNACES
UNIT IX**

**PRACTICAL TEST #6
JOB SHEET #6 — INSTALL A RETROFIT PACKAGE TO REPLACE
A STANDING PILOT WITH A CYCLING PILOT**

Student's name _____ Date _____

Evaluator's name _____ Attempt no. _____

Student instructions: When you are ready to perform this task, ask your instructor to observe the procedure and complete this form. All items listed under "Process Evaluation" must receive a "yes" for you to receive an overall performance evaluation.

PROCESS EVALUATION

(EVALUATOR NOTE: Place a check mark in the "Yes" or "No" blanks to designate whether or not the student has satisfactorily achieved each step in this procedure. If the student is unable to achieve this competency, have the student review the materials and try again.)

The student:	YES	NO
1. Inspected and verified components in retrofit package.	<input type="checkbox"/>	<input type="checkbox"/>
2. Completed system check before shutting off gas and power.	<input type="checkbox"/>	<input type="checkbox"/>
3. Removed existing gas valve and thermocouple.	<input type="checkbox"/>	<input type="checkbox"/>
4. Installed retrofit components and new gas valve.	<input type="checkbox"/>	<input type="checkbox"/>
5. Leak-checked gas piping.	<input type="checkbox"/>	<input type="checkbox"/>
6. Verified proper operation of retrofit and cycling pilot.	<input type="checkbox"/>	<input type="checkbox"/>
7. Cycled system several times to assure smooth operation.	<input type="checkbox"/>	<input type="checkbox"/>
8. Placed new lighting instructions over existing instructions.	<input type="checkbox"/>	<input type="checkbox"/>

Evaluator's comments: _____

JOB SHEET #6 PRACTICAL TEST

PRODUCT EVALUATION

(EVALUATOR NOTE: Rate the student on the following criteria by circling the appropriate numbers. Each item must be rated at least a "3" for mastery to be demonstrated. (See performance evaluation key below.) If the student is unable to demonstrate mastery, student materials should be reviewed and another test procedure must be submitted for evaluation.)

Criteria: _____

Existing system operation verification	4	3	2	1
Retrofit application	4	3	2	1
Safety verifications	4	3	2	1
Retrofit operation verification	4	3	2	1

EVALUATOR'S COMMENTS: _____

PERFORMANCE EVALUATION KEY

- 4 — **Skilled** — Can perform job with no additional training.
- 3 — **Moderately skilled** — Has performed job during training program; limited additional training may be required.
- 2 — **Limited skill** — Has performed job during training program; additional training is required to develop skill.
- 1 — **Unskilled** — Is familiar with process, but is unable to perform job.

(EVALUATOR NOTE: If an average score is needed to coincide with a competency profile, total the designated points in "Product Evaluation" and divide by the total number of criteria.)

**STANDARD GAS-FIRED FURNACES
UNIT IX**

TEST

Name _____ Score _____

1. Match the terms on the right with their correct definitions.

- | | | | |
|---------|--|-----|------------------------------|
| _____a. | A device for adjusting gas line pressure to the pressure specified by the appliance manufacturer | 1. | Bonnet |
| _____b. | An electric switch which prevents a gas valve from opening unless a pilot light is present | 2. | Gas valve |
| _____c. | An electrical device that controls the flow of gas; can be millivolt, 24V, or 115V depending on application | 3. | High limit switch |
| _____d. | Plugs threaded or pressed into gas burner manifolds; their small, precisely drilled holes meter precise amounts of gas to individual burners | 4. | Gas pressure regulator |
| _____e. | An adjustable opening on a gas burner which meters the amount of air to mix with the gas in order to produce a proper flame | 5. | Thermocouple |
| _____f. | A small opening in a gas burner which diverts a small amount of gas to the vicinity of the pilot flame to assist in a quick, even lighting of all burners in a gas furnace | 6. | Pilot safety control |
| _____g. | Serves as a safety device on gas furnaces to cut off the gas supply in the event of loss of flame in the pilot light | 7. | Retrofit |
| _____h. | An electrical device on gas furnaces that cuts off the gas supply if the furnace overheats | 8. | Primary shutter |
| _____i. | An air collection chamber | 9. | Solenoid valve |
| _____j. | An electrically operated valve that controls the flow of gas | 10. | Orifice inserts |
| | | 11. | Pilot runner |
| | | 12. | ECO |
| | | 13. | AFUE |
| | | 14. | Combustion triangle |
| | | 15. | L.P. Gas |
| | | 16. | Blower door interlock switch |
| | | 17. | Redundant |
| | | 18. | Thermopile |
| | | 19. | Combustion |
| | | 20. | Flame rollout switch |
| | | 21. | Flue temperature switch |

TEST

- ___k. To remodel or repair; in HVAC it generally means replacing older system components with new components that conserve energy and upgrade the system
- ___l. Rapid oxidation of fuel accompanied by the production of heat or light or both
- ___m. Fuel, oxygen and ignition temperature; three conditions that must be present for combustion
- ___n. Annual fuel utilization efficiency expressed as a percentage
- ___o. Butane, propane or a mixture of the two
- ___p. Device to interrupt operation if the temperature exceeds normal operation
- ___q. A device capable of generating up to 500 mV so it can operate a gas valve without need of an electrical source
- ___r. A gas valve that actually has dual valves so that either valve can shut off the gas supply in the event of pilot or ignition failure
- ___s. A switch located in the flue to shut down the gas valve in the event flue temperature reaches an unsafe level
- ___t. A switch located near the burner assembly so it can sense when flames begin to roll out the front of the furnace and shut off the gas supply
- ___u. A switch which interrupts the electrical power source and shuts down the entire system if the blower compartment door is open

TEST

2. Complete statements concerning furnace classifications. Circle the material that best completes each statement.
- Furnaces are generally classified according to their (AFUE) (OSHA) which is expressed as a percentage.
 - Generally, standard gas-fired furnaces have an efficiency below (78%) (72%) and high-efficiency gas-fired furnaces have an efficiency above (78%) (72%).
 - Standard gas-fired furnaces usually have standing pilots or (automatic ignition) (condensing) pilots which fire the main gas burners.
 - High efficiency gas-fired furnaces may be induced draft furnaces, pulse furnaces, or condensing furnaces with components and design that promote (high efficiency) (low cost).
3. Solve problems concerning gas furnace safety. Select the best solution to each of the following problems.
- A fellow service person suggests that the blower door safety switch on a certain type of furnace is easy to bypass if you have to. What is the problem and what is the solution? _____.
 - There is no problem so no solution is needed.
 - The problem is with the blower door switch. Some other switch should be selected.
 - The problem is attempting to bypass a safety control. Replace the control if defective.
 - A customer is anxious to get a furnace back in operation, but you don't have the high limit switch needs to be replaced and you do not have the proper replacement. What is the problem and what is the solution.
 - The problem is that an improper replacement part should not be used. The solution is to call for the right part and have someone bring it to you.
 - The problem is not really too bad. The solution is to use an improper switch overnight and put the right switch in tomorrow.
 - The problem is that the thermostat is set too high. Use the wrong switch, but turn the thermostat down.

TEST

4. Identify parts of the combustion triangle

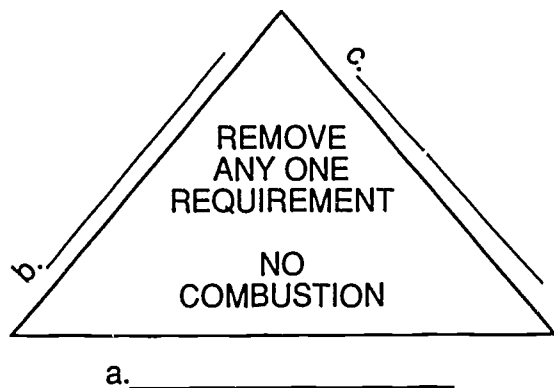

5. Match types of gas furnaces with their applications.

- | | | | |
|----------|--|----|-------------|
| _____ a. | Installed where headroom is not a problem | 1. | Lowboy |
| _____ b. | Installed where basement or crawl space cannot be used, and supply ducts are located under the floor | 2. | Outdoor |
| _____ c. | Installed in crawl space or attic where headroom is limited | 3. | Upflow |
| _____ d. | Installed outside and ducted into the structure | 4. | Counterflow |
| _____ e. | Installed in basements where headroom is limited | 5. | Horizontal |

TEST

6. Identify major components of a standing pilot furnace by correctly labeling the following illustration.

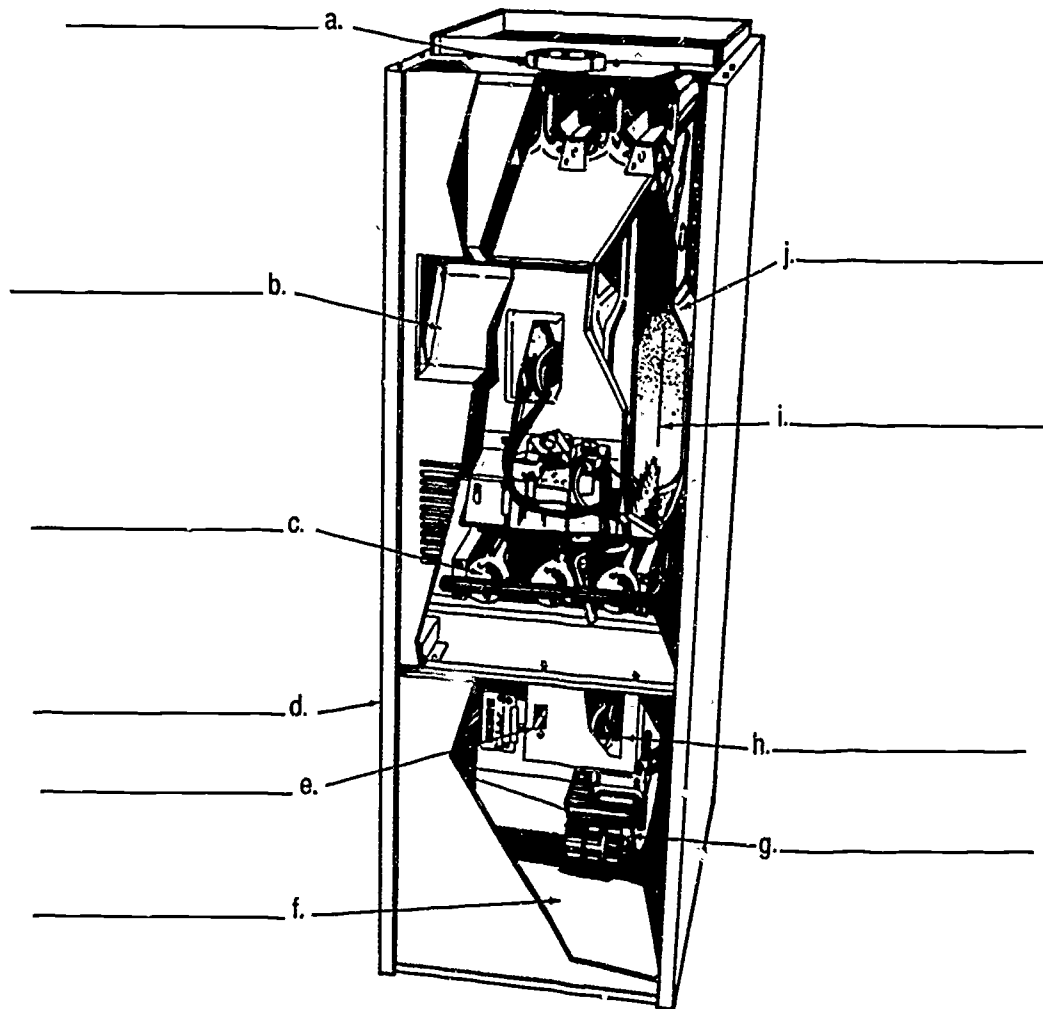

TEST

7. Match automatic ignition systems with their operations.

- | | |
|---|---|
| <p>_____ a. On a call for heat, gas at a reduced pressure is sent to a burner where a high voltage spark ignites the gas directly; the electronic module then allows the gas valve to increase manifold pressure to the burners.</p> <p>_____ b. Works much like another automatic system except that a hot surface is used to ignite the gas instead of a spark, and the ignition works off line voltage.</p> <p>_____ c. On a call for heat, gas is sent to the pilot burner where it is ignited by a high voltage spark; when the pilot is established, the electronic module allows the main gas valve to open.</p> | <p>1. Hot surface ignition</p> <p>2. Spark to pilot to burner</p> <p>3. Direct spark ignition</p> |
|---|---|

TEST

8. Identify components of a gas burner assembly by correctly labeling the following illustration.

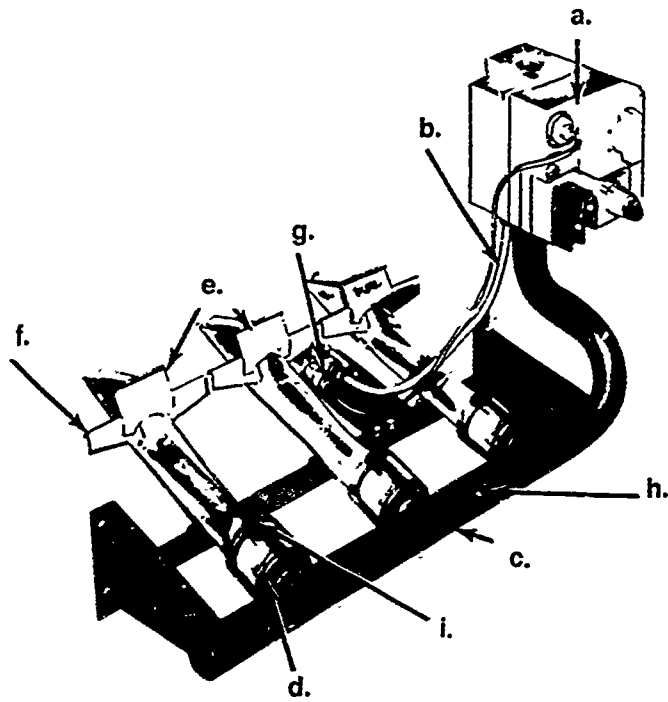

- a. _____
- b. _____
- c. _____
- d. _____
- e. _____
- f. _____
- g. _____
- h. _____
- i. _____

TEST

9. Match types of gas valves with their characteristics.

- | | | | |
|---------|---|----|---------------|
| _____a. | Opens instantly when energized | 1. | Slow opening |
| _____b. | Opens after a lapse of one to thirty seconds when energized | 2. | Instantaneous |
| _____c. | Combines other gas burner assembly components such as pressure regulator, pilot gas valve, and pilot safety | 3. | Combination |
| _____d. | Opens at reduced pressure and then steps up to full manifold pressure | 4. | Step opening |
| _____e. | A valve with two main gas valves in one body so that both valves open and close on every call for heat to assure shutdown in the event of pilot or ignition failure | 5. | Redundant |

TEST

10. Identify components of a combination electric gas valve by correctly labeling the following illustration.

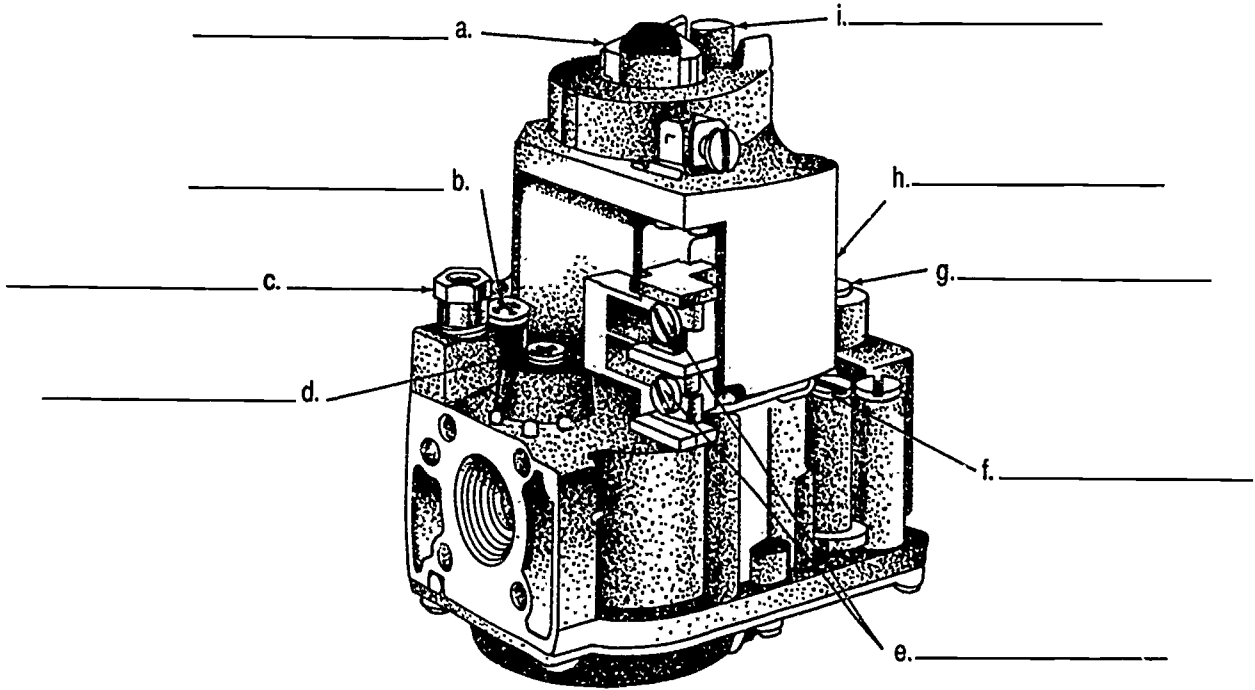

TEST

11. Select true statements concerning characteristics of heat exchangers. Place an "X" beside each true statement.
- a. Constructed to provide efficient heat transfer from the burner to air in the exchanger while keeping flue gases separate from air circulated in the duct system
 - b. May be composed of units called "clamshells"
 - c. Designed to transfer a specific amount of heat per hour of operation
 - d. Each clamshell has triple burners
12. Select true statements concerning characteristics of draft diverters. Place an "X" beside each statement that is true.
- a. A draft diverter collects flue gases from upper opening of heat exchanger and funnels them into the vent without pulling excess air over the flames.
 - b. A draft diverter should be closed to the atmosphere.
 - c. A draft diverter induces unheated air into vent pipe to reduce temperature of flue gases.
 - d. A draft diverter prevents wind that enters the vent pipe from blowing out the pilot.
13. Identify the types of blower assemblies shown in the following illustrations.

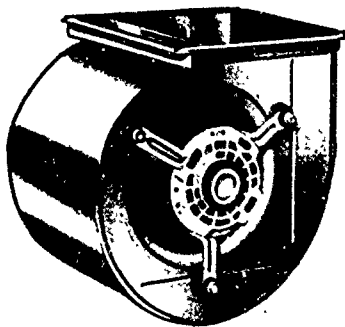

a. _____

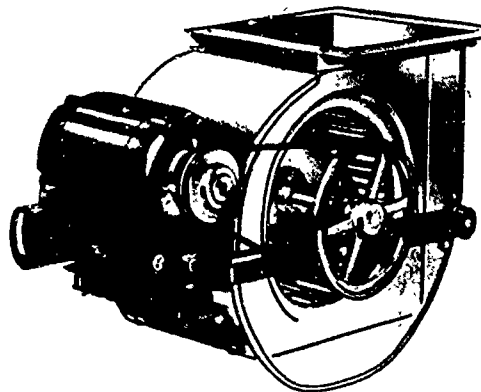

b. _____

TEST

14. Select from the following list components of a control system. Place an "X" beside each device that applies.

- a. Transformer
- b. Thermostat
- c. Stack pressure switch
- d. Electric gas valve
- e. Limit switch
- f. Fan switch
- g. Draft diverter
- h. Combination fan-limit switch
- i. Pilot light
- j. Thermocouple
- k. Pilot safety

15. Complete statements concerning the functions of a transformer. Circle the material that best completes each statement.

- a. Reduces supply voltage to (12 volts) (24 volts).
- b. Furnishes power for (emergency) (control) circuit.
- c. A transformer used for both heating and cooling has a VA rating of (25) (40).

16. Match types of thermostats with their functions.

- | | | |
|-----------------------------|---|------------------------------|
| <input type="checkbox"/> a. | 1) Consists of one switch which closes on a drop in temperature | 1. Heat only thermostats |
| | 2) Have only a heat anticipator | 2. Heat and cool thermostats |
| | 3) May have a set back energy conservation feature | 3. Heat anticipator |
| <input type="checkbox"/> b. | 1) Temperature operated heating switch closes on drop in room temperature | |
| | 2) Temperature operated cooling switch closes on increase in room temperature | |

TEST

- 3) Manually operated fan switch closes circuit to fan relay
 - 4) Operate on room temperature and heat from the anticipator
 - 5) Have both heating and cooling anticipators
 - 6) May have a set back energy conservation feature
 - 7) May be snap action, Mercury bulb or electronic solid state type
 - 8) Mercury bulb thermostats must be level and mounted firmly
- _____c.
- 1) Adds a small amount of heat in the thermostat during the "on" part of the heating cycle to prevent room overheating and narrows the mechanical differential of the thermostat
 - 2) Should be set to match the current draw of the heating circuit or to the appliance manufacturer's recommended setting if known
 - 3) Set too low causes short cycling
 - 4) Set too high causes too long a cycle resulting in a wide temperature differential
 - 5) Is the weakest point in the heating circuit and may be ruined by careless "jumpering" of components when troubleshooting
17. Select true statements concerning limit switch operation. Place an "X" beside each true statement.
- _____a. Opens on temperature rise
 - _____b. Senses bonnet temperature
 - _____c. Set at 180 to 200 degrees depending on make and model
 - _____d. Interrupts circuit to gas valve or transformer

TEST

- e. May be separate or combined with fan switch
 f. Designed to shut off gas supply to burners if furnace overheats
 g. In some models will bypass fan switch to bring on blower while furnace is overheated
18. Select true statements concerning fan switch operation. Place an "X" beside each true statement.
- a. Closes on temperature rise
 b. Senses bonnet temperature
 c. Adjustable "on" switch approximately 100 to 180 degrees
 d. Adjustable "off" switch approximately 20 to 80 degrees cooler than "on" switch
 e. Most types of fan switches for gas furnaces are designed to close supply circuit to blower motor when furnace is hot
 f. May be combined with limit switch
19. Select true statements concerning combination fan-limit switch operation. Place an "X" beside each true statement.
- (NOTE: For a statement to be true, all parts of the statement must be true.)
- a. Combines complete set of fan switches
 b. Contains pre-set high limit switch
- 1) May control gas valve on 115 volts
 2) May control transformer supply circuit on house current of 230 volts
20. Describe pilot light operation.
- a. _____
- b. _____
21. Describe thermocouple operation.
- a. _____
- b. _____

TEST

22. Describe pilot safety operation

- a. _____
b. _____

23. Select true statements concerning potential sources of thermocouple failure. Place an "X" beside each true statement.

(NOTE: For a statement to be true, all parts of the statement must be true.)

- ____ a. May fail to generate enough voltage to hold open the gas valve or pilot safety
- ____ b. Tip may be turned out because pilot flame is too cold
- ____ c. May not be getting enough heat from pilot flame
- 1) Not properly positioned in pilot flame
- 2) Soot build up insulates thermocouple

24. Solve problems concerning potential sources of fan switch failure. Select the best solution to each of the following.

- a. You are trouble shooting a furnace fan that runs all the time. The problem is probably that ____.
- 1) The damper in the flue is stuck open.
- 2) The contacts are stuck together.
- 3) The transformer is weak.
- b. You are troubleshooting a fan that comes on too soon. The problem is probably that ____.
- 1) The transformer is weak.
- 2) The upper limit switch is out.
- 3) Fan switch temperature setting is unreliable.

TEST

25. Solve problems concerning potential sources of transformer failure. Select the best solution to each of the following.
- a. You have established that a transformer is burned out. The problem is probably that _____.
 - 1) The primary windings are burned out.
 - 2) The secondary windings are burned out.
 - 3) Either the secondary or primary windings are burned out.
 - b. The customer wants to know why the transformer burned out. Your best answer is _____.
 - 1) Transformers sometimes fail for no apparent reason.
 - 2) I'll have to check manufacturer's literature.
 - 3) It just grew too old.
26. Solve problems concerning potential sources of high limit switch failure. Select the best solution to each of the following.
- a. The high limit switch does not open in the presence of furnace overheating. The problem is that _____.
 - 1) The normally closed switch will not open.
 - 2) The wiring to the switch is faulty.
 - 3) The transformer in line with the switch is faulty.
 - b. The high limit switch appears to be okay so a possible reason it is not working is that _____.
 - 1) The transformer is gone.
 - 2) The switch cover is jammed against it or burned insulation is causing wires to touch.
 - 3) The limit switch went out for no apparent reason.

TEST

27. Solve problems concerning potential sources of gas valve failure. Select the best solution to each of the following.

- a. You test for gas valve failure and you will probably find that ____.
- 1) The gas valve will not open.
 - 2) The gas valve will only partially open.
 - 3) The gas valve will not close.
- b. A customer reports a problem with a gas valve that will not close. You suspect the problem may be otherwise because ____.
- 1) Gas valve problems always involve a transformer.
 - 2) Gas valves rarely fail because they will not close.
 - 3) Gas valves never fail because they will not close.

28. Select true statements concerning potential sources of fan relay failure. Place an "X" beside each true statement.

- ____ a. Contacts stick together causing blower to short out
- ____ b. Fails to close when 24 volts is applied
- ____ c. Contacts fail to close fan circuit

29. Match potential blower section failure with component sources.

- | | | |
|---------|---|---------------------------------|
| ____ a. | 1) Bearing seizure because of improper oiling | 1. Blower belts |
| | 2) Burned out or shorted motor windings | 2. Blower wheels out of balance |
| | 3) Bad capacitor | 3. Aluminum split pulleys |
| | 4) Fireplace ducted into return air may cause overheating | 4. Blower speed |
| ____ b. | 1) Destroyed because of improper oiling | 5. Blower wheel |
| | 2) Destroyed because of excessive belt tension | 6. Blower motors |
| | | 7. Blower bearings |

TEST

- ____c. 1) Cracked, frayed, or broken
 2) Too loose
 3) Too tight
- ____d. Can seize to motor shaft and cannot be pulled off without destruction
- ____e. 1) Balance weight has come off
 2) Can only be rebalanced at the factory
- ____f. Running backwards because of improper replacement
- ____g. 1) Creates excessive noise
 2) Causes temperature stratification resulting in cold spots and hot spots in the room
 3) Drawing too much current and blowing fuses
 4) Providing inadequate cooling after air conditioning has been added
30. Differentiate between potential sources of heat exchanger failure by placing an "S" beside statements related to soot buildup between clamshells and a "C" beside statements related to a cracked heat exchanger.
- ____a. Should be suspected when customer complain of pilot light blowing out
- ____b. Identified by visual inspection with flashlight and small mirror
- ____c. Usually identified by flames spilling out front of furnace even if the blower is not running
- ____d. Flames frequently cause extensive damage to wires and electrical components
- ____e. Starts as hairline cracks in sharper bends at bottom of clamshells
- ____f. Cracks open wider in presence of heat from burner flames and create a potential hazard for occupants
- ____g. Usually requires burner and baffle removal to clean between these with wire and vacuum cleaner

TEST

31. Select true statements concerning potential sources of pilot safety failure. Place an "X" beside each true statement.
- a. Usually evidenced by failure to open gas valve after replacement of thermocouple
 - b. Kills power to gas valve unless operating properly with adequate thermocouple voltage
 - c. On furnace without 100% shut-off gas valves
 - d. Never caused by downdraft
32. Complete a list of factors needed to determine gas pipe sizing.
- a. Specific gravity and Btu per cubic foot heating value of gas supply
 - b. _____
 - c. _____
 - d. Maximum capacity of pipe related to cubic feet or gas per hour
33. Complete a list of energy conservation devices designed for retrofitting.
- a. Set back thermostats
 - b. _____
 - c. _____
34. Select true statements concerning set back thermostats. Place an "X" beside each statement that is true.
- a. Designed to let structure move to a higher room temperature at night
 - b. Reduces heat loss because of lower temperature differential
 - c. Reduces fuel consumption because of reduced heat loss
 - d. Can be operated only by a timer
 - e. Can be fully automated with clock operation and also provide a manual override feature

TEST

35. Select true statements concerning intermittent ignition systems. Place an "X" beside each true statement.
- a. Eliminates cost of fuel to pilot flame
 - b. Can operate only from a direct spark ignition
 - c. Good proven-pilot or cycling-pilot systems are built with a "redundant" safety system which requires that the pilot light be proven with an electric or an electro-mechanical sensor before gas will flow to the main burners
 - d. Are being incorporated into many new furnace designs
36. Select true statements concerning vent dampers and their uses. Place an "X" beside each true statement.
- a. Are designed to stay open while burner is operating in order to vent combustion gases
 - b. Are designed to close when burner shuts off to stop heat from escaping up the flue or chimney
 - c. Are relatively easy to install, and can be installed by anybody
 - d. Some manufacturers are building furnaces with control wiring installed for adding a vent damper
37. Select true statements concerning combustion air for a gas furnace. Place an "X" beside each statement that is true.
- a. A furnace should be installed in a location that permits a proper supply of air for combustion and venting.
 - b. The furnace location should also provide for proper ventilation to help maintain an ambient temperature at safe limits under normal operating conditions.
 - c. The size of openings for combustion and ventilation depend on the location of the openings and the BTUH input to the furnace or appliance.

TEST

(NOTE: If the following activities have not been accomplished prior to the test, ask your instructor when they should be completed.)

38. Trace the high voltage and low voltage circuits of a gas furnace. (Assignment Sheet #1)
39. Construct wiring diagrams for gas furnaces. (Assignment Sheet #2)
40. Size a gas piping system. (Assignment Sheet #3)
41. Demonstrate the ability to:
 - a. Install a gas furnace. (Job Sheet #1)
 - b. Start and adjust a gas furnace. (Job Sheet #1)
 - c. Disassemble, inspect, and reassemble an upflow gas furnace. (Job Sheet #3)
 - d. Perform maintenance on a gas furnace. (Job Sheet #4)
 - e. Troubleshoot a gas furnace on a "no heat" complaint. (Job Sheet #5)
 - f. Install a retrofit package to replace a standing pilot with a cycling pilot. (Job Sheet #6)

STANDARD GAS-FIRED FURNACES UNIT IX

ANSWERS TO TEST

1.

a.	4	f.	11	k.	7	p.	12
b.	6	g.	5	l.	19	q.	18
c.	9	h.	3	m.	14	r.	17
d.	10	i.	1	n.	13	s.	21
e.	8	j.	2	o.	15	t.	20
						u.	16

2.
 - a. AFUE
 - b. 78%, 78%
 - c. Automatic ignition
 - d. High efficiency

3.
 - a. 3
 - b. 1

4. In any order:

a. Air	b. Fuel	c. Heat
--------	---------	---------

5.

a.	3	d.	2
b.	4	e.	1
c.	5		

6.

a. Flue	f. Air filter
b. Draft diverter	g. Blower assembly
c. Burner assembly	h. Control compartment
d. Cabinet	i. Combustion chamber
e. Blower door interlock switch	j. Heat exchanger

7.
 - a. 3
 - b. 1
 - c. 2

8.

a. Gas valve	e. Burners
b. Pilot burner gas supply	f. Pilot runner
c. Manifold and orifices	g. Pilot burner and thermocouple assembly
d. Primary air shutter	h. Tap for measuring manifold pressure
	i. Locking screw

ANSWERS TO TEST

9. a. 2
b. 1
c. 3
d. 4
e. 5
10. a. Main gas line shut off
b. Pilot gas adjustment
c. Pilot gas connection
d. Outlet pressure tap
e. Electrical terminals
f. Gas pressure regulator adjustment
g. Inlet pressure tap
h. Thermocouple connection
i. Pilot gas shut off valve and safety reset/lighting button
11. a, b, c
12. a, c, d
13. a. Direct drive
b. Belt drive
14. a, b, d, e, f, h, i, j, k
15. a. 24 volts
b. Control
c. 40
16. a. 1
b. 2
c. 3
17. a, b, c, d, e, f, g
18. a, b, e, f
19. a

ANSWERS TO TEST

20. Description should include:
- Furnishes heat to thermocouple tip
 - Small flame lights main burners when gas valve opens
21. Description should include:
- Converts heat from pilot flame into electric current which operates pilot safety
 - Connects electrically to pilot safety
22. Description should include:
- Opens control circuit to main gas valve in case of pilot outage
 - May be incorporated into combination gas valve or as a separate device
23. a, c
24. a. 2
b. 3
25. a. 3
b. 1
26. a. 1
b. 2
27. a. 1
b. 2
28. b, c
29. a. 6 e. 2
b. 7 f. 5
c. 1 g. 4
d. 3
30. a. c e. c
b. c f. c
c. s g. s
d. s

ANSWERS TO TEST

31. a, b, c
32. Order may vary:
- b. Btuh rating of gas outlet
 - c. Distance from gas meter to the appliance outlet
33. Order may vary:
- b. Intermittent ignition systems
 - c. Vent damper (if combustion air is from heated space)
34. b, c, e
35. a, c, d
36. a, b, d
37. a, b, c
- 39-40. Evaluated according to answers to assignment sheets
41. a. Evaluated according to criteria in Practical Test #1
b. Evaluated according to criteria in Practical Test #2
c. Evaluated according to criteria in Practical Test #3
d. Evaluated according to criteria in Practical Test #4
e. Evaluated according to criteria in Practical Test #5
f. Evaluated according to criteria in Practical Test #6



HIGH-EFFICIENCY GAS-FIRED FURNACES

UNIT X

UNIT OBJECTIVE

After completion of this unit, the student should be able to trace the high and low voltage circuitry on induced air and condensing furnaces and troubleshoot a "no heat" complaint on induced air and condensing furnaces. These competencies will be evidenced by completing the assignment and job sheets and by scoring a minimum of 85 percent on the unit test.

SPECIFIC OBJECTIVES

After completion of this unit, the student should be able to:

1. Match terms related to high-efficiency gas-fired furnaces with their correct definitions.
2. Select true statements concerning induced draft furnaces.
3. Complete statements concerning condensing furnaces.
4. Complete statements concerning pulse furnaces.
5. Select true statements concerning safety with high-efficiency furnaces.
6. Solve problems concerning maintaining and servicing high-efficiency furnaces.
7. Trace the high voltage circuitry for an induced draft furnace. (Assignment Sheet #1)
8. Trace the low voltage circuitry for an induced draft furnace. (Assignment Sheet #2)
9. Demonstrate the ability to:
 - a. Troubleshoot an induced draft furnace on a "no heat" complaint. (Job Sheet #1)
 - b. Troubleshoot a condensing furnace on a "no heat" complaint. (Job Sheet #2)

HIGH-EFFICIENCY GAS-FIRED FURNACES UNIT X

SUGGESTED ACTIVITIES

- A. Obtain additional materials and/or invite resource people to class to supplement/reinforce information provided in this unit of instruction.

(NOTE: This activity should be completed prior to the teaching of this unit.)

- B. Make transparencies from the transparency masters included with this unit.
- C. Provide students with objective sheet.
- D. Discuss unit and specific objectives.
- E. Provide students with information and assignment sheets.
- F. Discuss information and assignment sheets.

(NOTE: Use the transparencies as needed to enhance the information.)

- G. Provide students with job sheets.
- H. Discuss and demonstrate the procedures outlined in the job sheets.
- I. Integrate the following activities throughout the teaching of this unit:
1. Demonstrate the use of a combustion test kit, and discuss with students the value of using proper test instruments, especially with high-efficiency furnaces.
 2. Point out to students troubleshooting high-efficiency furnaces is like troubleshooting standard furnaces, and then discuss the finer points of troubleshooting that make high-efficiency furnaces different.
 3. Demonstrate how to determine BTUH input to a gas fired furnace by timing the gas meter.
 4. Meet individually with students to evaluate their progress through this unit of instruction, and indicate to them possible areas for improvement.

- J. Give test
- K. Evaluate test.
- L. Reteach if necessary.

SUGGESTED ACTIVITIES**REFERENCES USED IN DEVELOPING THIS UNIT**

- A. Althouse, Andrew D., and Carl H. Turnquist and Alfred C. Bracciano. *Modern Refrigeration and Air Conditioning*, South Holland, IL: The Goodheart-Wilcox Company, Inc., 1988.
- B. Eckes, William, and Dan Fulkerson. *Air Conditioning and Refrigeration, Book Four*. Stillwater, OK 74074: Mid-American Vocational Curriculum Consortium, 1981.
- C. *Condensing Gas Furnace Service Manual*. Lavergne, TN 37086: Heil-Quaker Corporation, 1988.
- D. *Power Vent Furnace Service Manual*. Lavergne, TN 37086: Heil-Quaker Corporation, 1988.

HIGH-EFFICIENCY GAS-FIRED FURNACES UNIT X

INFORMATION SHEET

I. Terms and definitions

- A. **Condensing furnace** — A furnace that extracts heat from flue products to conserve energy and produces condensate that has to be drained off
- B. **Induced draft furnace** — A furnace that uses a special blower to control combustion air and the rate combustion gases are vented
- C. **Pulse furnace** — A high-efficiency furnace that uses a cycle of positive and negative pressures to ignite gas/air mixtures in cycles of 60 to 70 times per second
- D. **Secondary heat exchanger** — An additional heat exchanger that flue products pass through before being vented outdoors
- E. **Combustion air blower** — A small blower used on some furnaces to supply combustion air
- F. **Purge cycle** — The movement of air through a heat exchanger prior to combustion to get rid of unburned fuel and assure a smooth ignition
- G. **Lockout** — A circuit built into electronic ignition devices that automatically shuts down the entire system if ignition does not occur after a limited number of attempts
- H. **Air sensing switch** — A switch operated by air pressure to determine if a furnace is properly venting

II. Induced draft furnaces (Transparency 1)

- A. Induced draft furnaces accomplish high-efficiency performance by controlling the amount of air used for combustion.
- B. Combustion is controlled with an induced draft blower which controls the rate combustion gases are released up the flue.
- C. An induced draft furnace has almost all the same components as a standard gas-fired furnace with automatic ignition.
- D. Induced draft furnaces have two components not found on standard furnaces, the induced draft blower and an air sensing switch.
- E. The air sensing switch monitors the system for proper venting and shuts the system down if there are problems.

INFORMATION SHEET

III. Condensing furnaces (Transparency 2)

- A. Condensing furnaces accomplish high-efficiency performance by passing hot flue gases through a secondary heat exchanger to take advantage of heat that would otherwise be vented.
- B. In the process of condensing flue gases, condensate forms as part of the heat removal process, and the condensate has to be drained away.
- C. In cases where a condensing furnace is not located near a drain, a small pump may be required to pump the condensate to a proper point of discharge.

(CAUTION: Never extend a condensate drain to an outside area where it could freeze and cause serious system problems. Always drain condensate into a protected space.)

- D. A condensing furnace is similar to an induced draft furnace except that it has a secondary heat exchanger which is usually made of stainless steel.

(NOTE: Some manufacturers use stainless steel for the primary heat exchanger and the secondary heat exchanger.)

- E. Condensing furnaces are generally regarded as being the most efficient of high-efficiency furnaces and their ratings can run as high as 97% to 98%.

IV. Pulse furnaces (Handout #1)

- A. In a pulse furnace, a spark is used to ignite a gas/air mixture to begin the cycle, but ignition for later combustion is the product of back pressure ignition.
- B. Some pulse furnaces are actually condensing furnaces that use the pulse combustion process.
- C. In a pulse furnace, the initial combustion takes place in an enclosed chamber, then, as combustion products pass through the heat exchanger system into a coil, the latent heat is extracted by condensing water from the exhaust gas.
- D. Pulse furnaces use a small blower to purge the combustion chamber before and after each heating cycle to provide proper air mixture for start-up.
- E. Pulse furnaces use a redundant gas valve to assure safe shut-off, there is another sensor that verifies loss of combustion and will shut the system down, and obstructions to the air intake or outlet will also shut the system down.

V. Safety with high-efficiency furnaces

- A. Flue gas temperature on condensing furnaces is so low that a vent going through an unconditioned space should be insulated to keep vent vapor from freezing and blocking the vent.

(NOTE: Low vent temperatures permit the use of PVC vent pipe in some installations.)

INFORMATION SHEET

- B. Combustion air for some condensing furnaces can be taken directly from outside and help avoid problems with indoor contaminants such as aerosols and cleaning agents.
- C. Pulse furnaces produce a combustion vibration that requires special attention during installation. (See Handout #1)
- D. All high-efficiency furnaces should be sized as close as possible to the heating load because oversizing causes short cycling and reduces efficiency.

VI. Maintaining and servicing high-efficiency furnaces

- A. Burners in condensing furnaces should be kept as clean as possible in order to keep soot and other flue products to a minimum in the secondary heat exchanger.
- B. Dirty filters greatly diminish the efficiency of any furnace, and especially on high-efficiency furnaces where filters should be inspected often and changed as needed.
- C. Venting becomes a prime concern with all high-efficiency furnaces and manufacturer's specifications should be followed carefully during installation and for all maintenance and service.
- D. In servicing pulse furnaces, the manufacturer recommends that you do as little disassembly as possible to prevent introducing additional problems such as gas or air leaks that could damage components.

Induced Draft Furnace

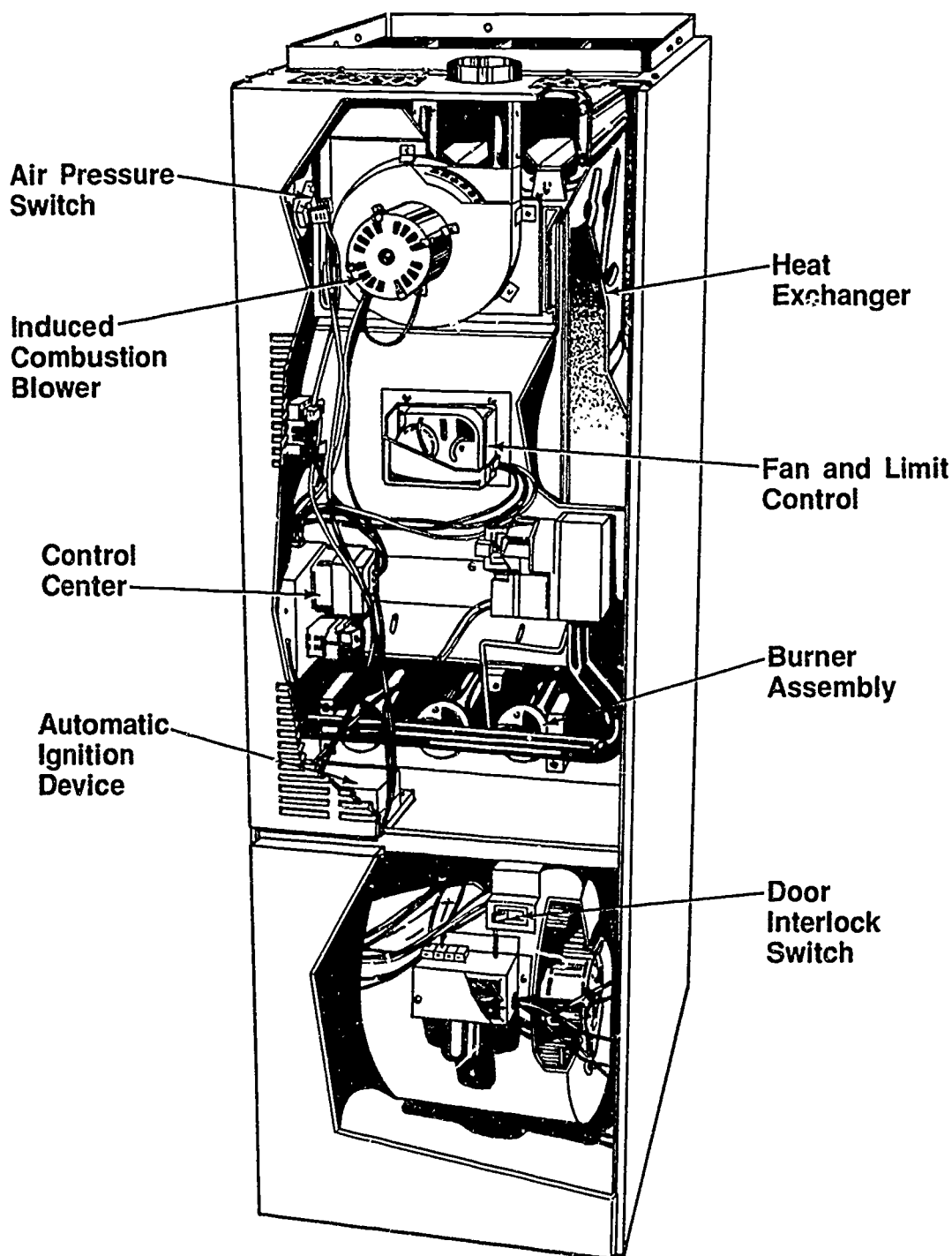

Courtesy Inter-City Products Corporation (USA)

Condensing Furnace

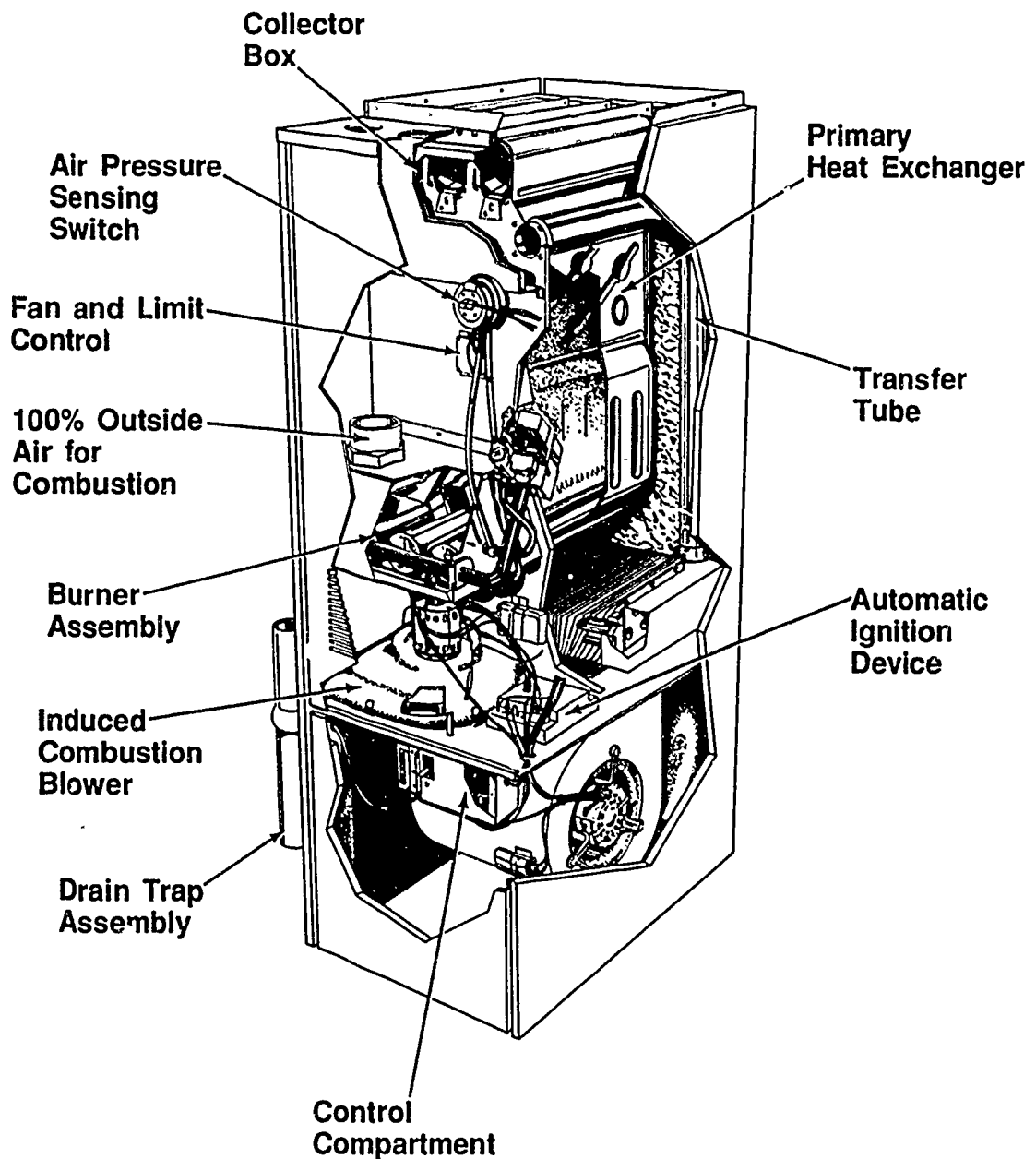

Courtesy Inter-City Products Corporation (USA)

HIGH EFFICIENCY GAS-FIRED FURNACES UNIT X

HANDOUT #1 — THE PULSE COMBUSTION PROCESS

Information and illustrations in this handout are adapted from materials published by Lennox Industries Inc. and are used with permission.

Purpose

The "pulse" furnace from Lennox brought several innovations into gas heating and improved heating efficiency in the process. Knowing the basics of the pulse combustion process and some of the special requirements for installation will assist an HVAC technician in keeping up with advances in furnace technology.

The pulse combustion process

The pulse combustion process starts as gas and air enter and mix in a combustion chamber. (Reference Figure 1 as we go through the rest of the process.) A spark is used to ignite the air and gas mixture and start the cycle. This initial ignition is one pulse. Combustion creates **positive** pressure which closes flapper valves and forces exhaust gases down a tailpipe. Exhaust gases leaving the chamber create a **negative** pressure. Negative pressure opens the flapper valves and draws in gas and air. At the same instant, part of the pressure pulse is reflected back from the tailpipe causing the new gas and air mixture to ignite. No spark is needed this time as another pulse occurs. This cycle is repeated 60 to 70 times per second to form consecutive pulses of 1/4 to 1/2 Btu each.

FIGURE 1

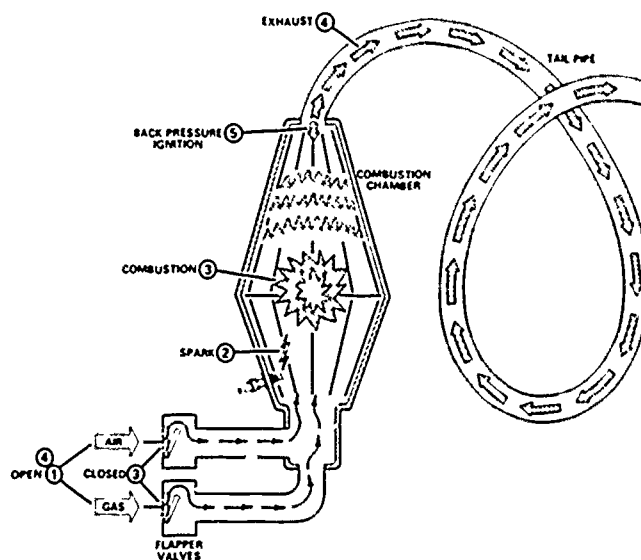

HANDOUT #1

Proper installation techniques for pulse furnaces

Figure 2 pinpoints important installation elements. Place Figure 2 alongside this material and follow it as you read through the installation notes.

Isolation mounting pads

If leveling bolts are not used, vibration isolating pads should be used especially when a pulse unit is installed on wood flooring. "Isomode" pads or equivalent should be used (Item 1).

Flexible boot supply and return air plenums

A flexible canvas boot or equivalent should be used in the supply air plenum, above the cooling coil or future coil location (Item 2). A flexible canvas boot should also be used with the return air plenum and located as close to the furnace as possible, preferably between the furnace and external electronic air cleaner, if used (Item 3).

Gas supply piping centered in inlet hole

AGA units only should use gas connectors (Item 4). The gas supply pipe itself should be centered in the inlet hole, not resting on the unit cabinet (Item 5).

Isolation hangars

PVC piping for intake and exhaust lines should be suspended from hangars. A suitable hanger can be fabricated from 1 2-inch wide strip of 26 gauge covered with "ARmaflex" or equivalent (Item 6).

Electrical conduit isolated from ductwork and joists

The electrical conduit can transmit vibration from the unit cabinet to ductwork or joists if clamped to either. The conduit may be clamped tightly to the unit cabinet, but should not touch ductwork or joists (Item 7).

Return/Supply air plenums insulated past first elbow

Both the return and supply air plenums would be insulated past the first elbow with a 1.5 to 3 lb. density, matt face, 1-inch thick insulation, and all exposed edges should be protected from air flow (Items 8 and 9).

HANDOUT #1

FIGURE 2

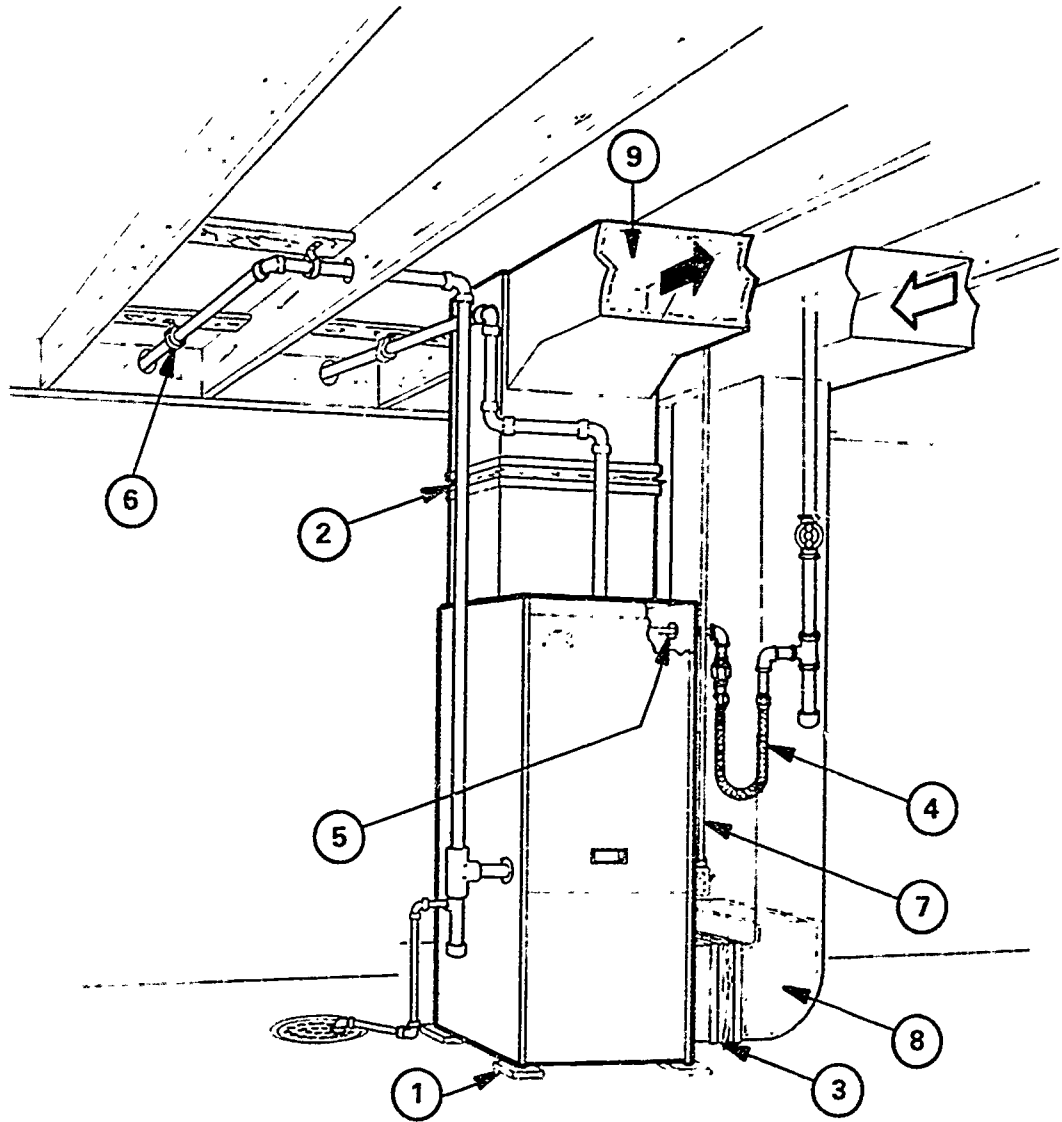

HIGH-EFFICIENCY GAS-FIRED FURNACES UNIT X

ASSIGNMENT SHEET #1—TRACE THE HIGH VOLTAGE CIRCUITRY FOR AN INDUCED DRAFT FURNACE

1. In the following connection diagram use a dark colored pencil to trace the high voltage circuit while the thermostat calls for heat.

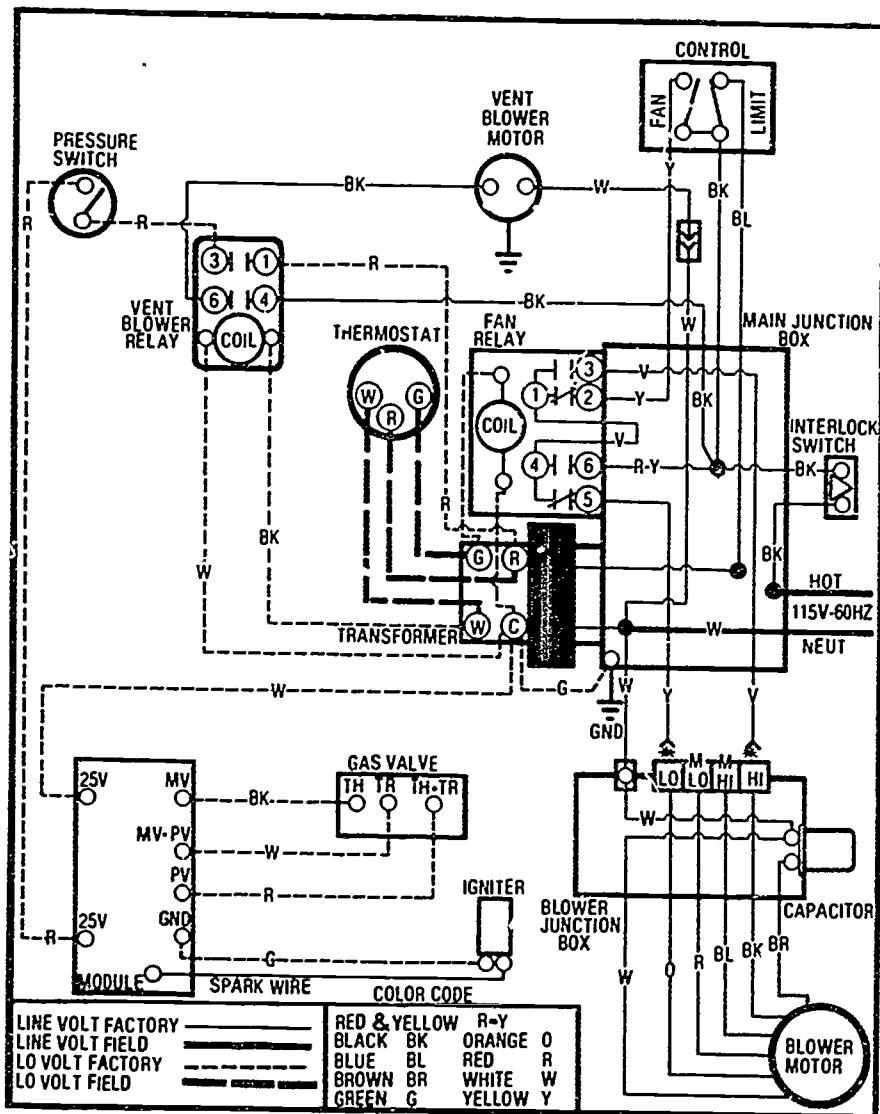

Have your instructor check your schematic.

Courtesy Inter-City Products Corporation (USA)

ASSIGNMENT SHEET #1

2. In the following ladder diagram, use a dark colored pencil to trace the high voltage circuit while the thermostat calls for heat.

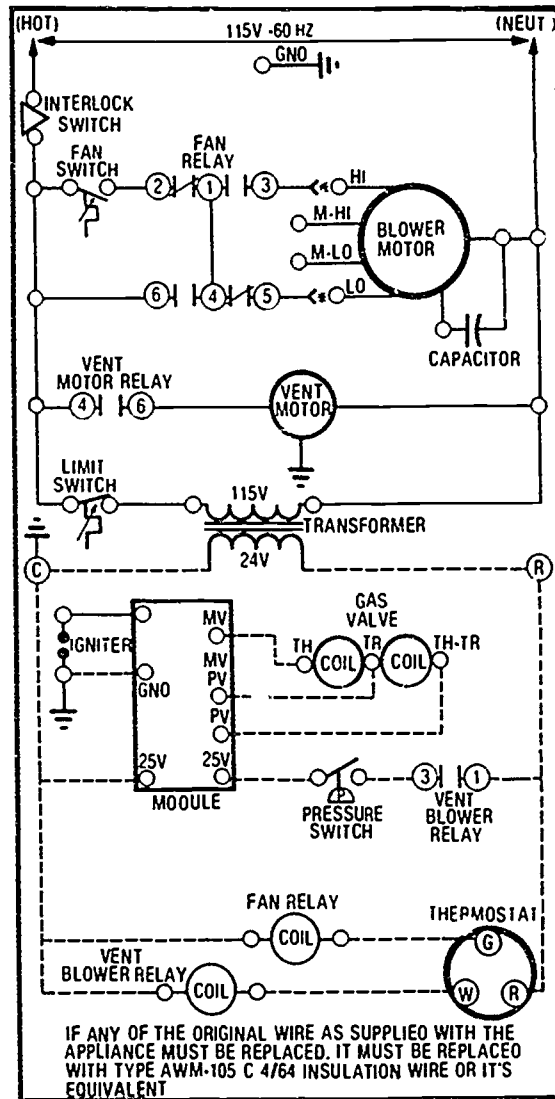

- Have you instructor check your ladder diagram.

Courtesy Inter-City Products Corporation (USA)

HIGH-EFFICIENCY GAS-FIRED FURNACES UNIT X

ASSIGNMENT SHEET #2—TRACE THE LOW VOLTAGE CIRCUITRY FOR AN INDUCED DRAFT FURNACE

1. In the following connection diagrams, use a dark colored pencil to trace the low voltage circuit while the thermostat calls for heat.

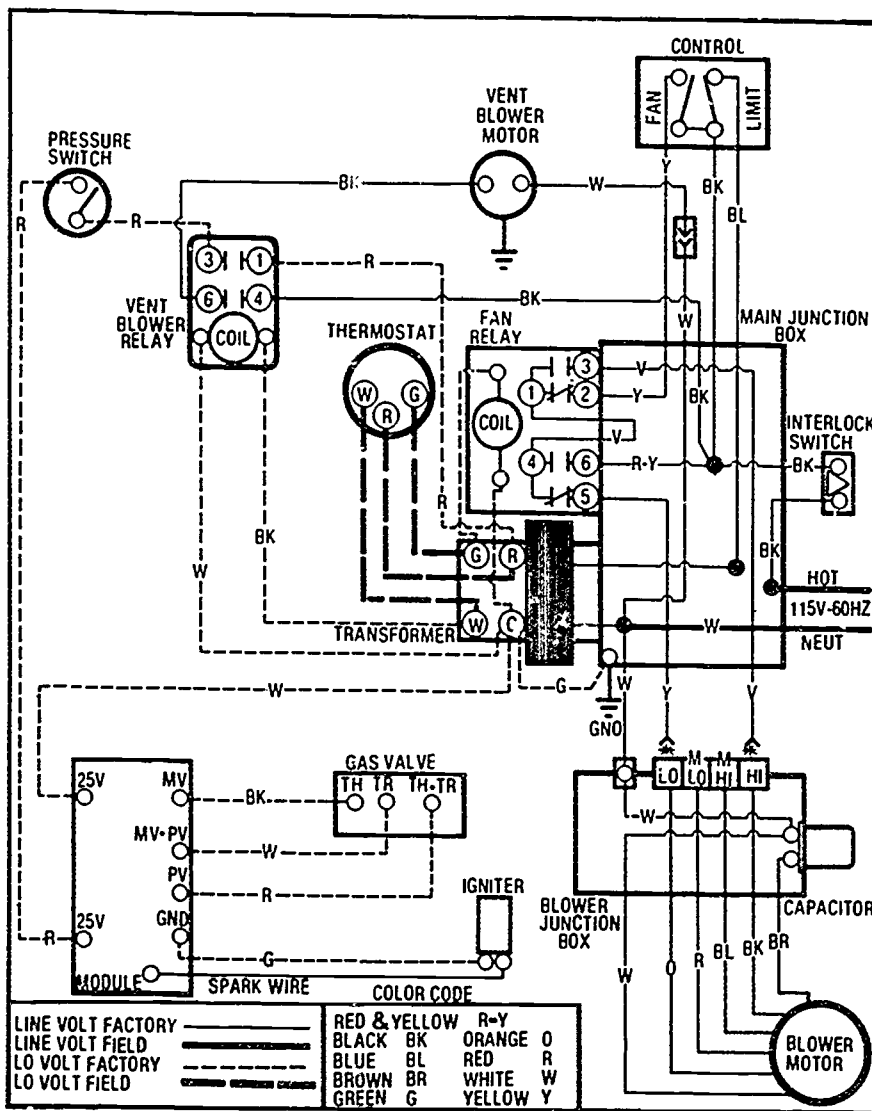

Have your instructor check your schematic.

Courtesy Inter-City Products Corporation (USA)

ASSIGNMENT SHEET #2

- In the following ladder diagram, use a dark colored pencil to trace the low voltage circuit while the thermostat calls for heat.

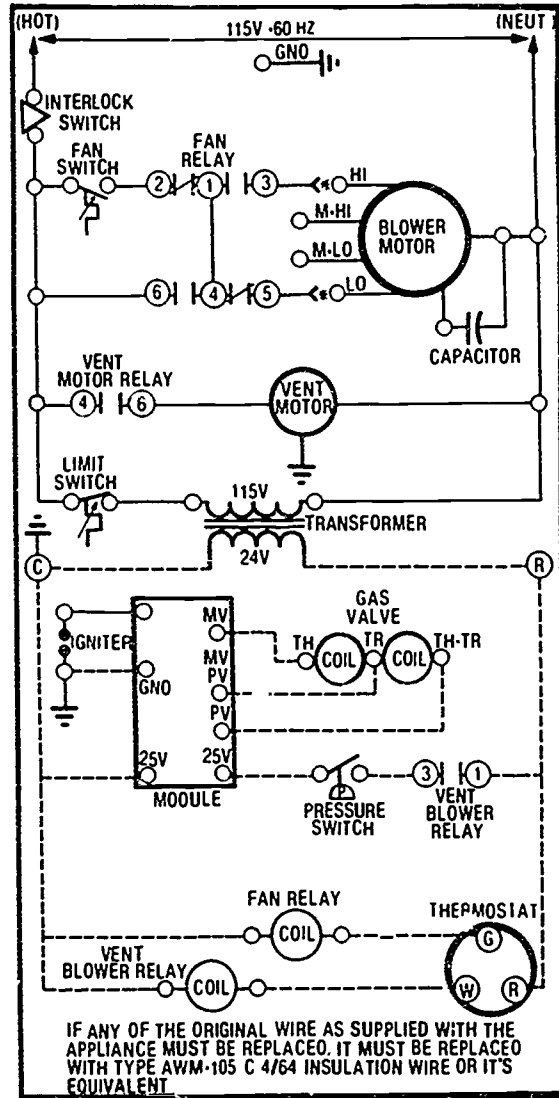

- Have your instructor check your ladder diagram.

Courtesy Inter-City Products Corporation (USA)

HIGH-EFFICIENCY GAS-FIRED FURNACES UNIT X

ANSWERS TO ASSIGNMENT SHEETS

Assignment Sheet #1

1.

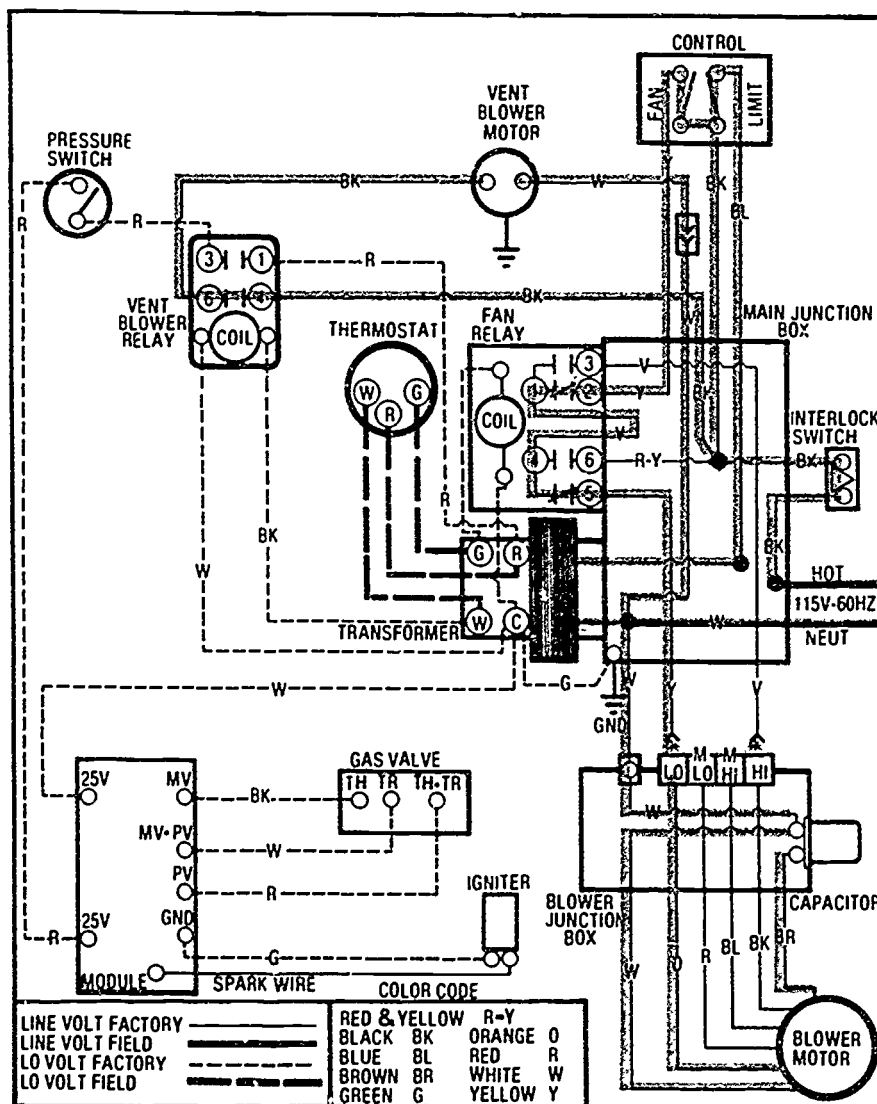

Courtesy Inter-City Products Corporation (USA)

ANSWERS TO ASSIGNMENT SHEETS

Assignment Sheet #1

2.

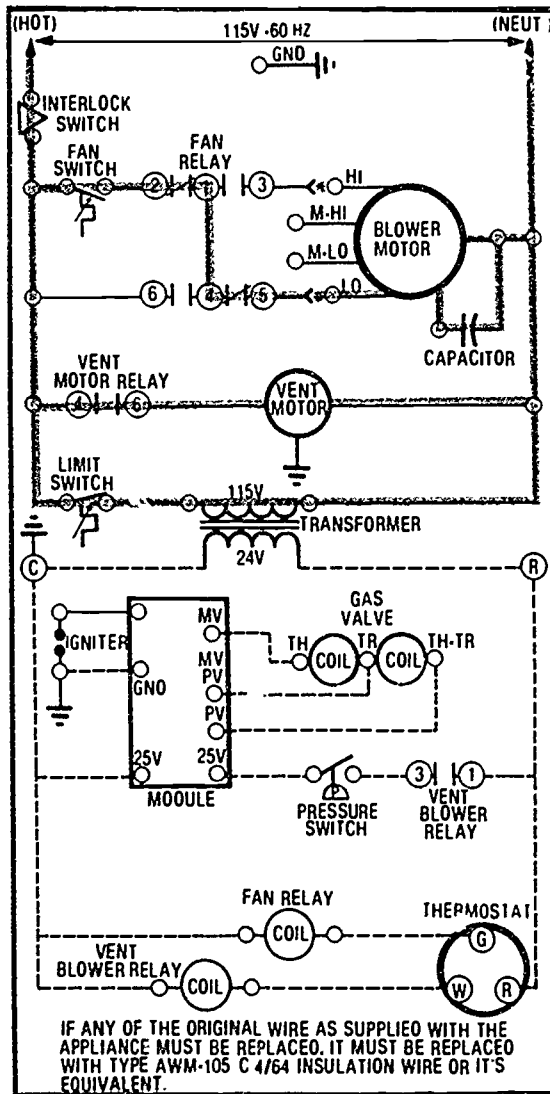

Courtesy Inter-City Products Corporation (USA)

ANSWERS TO ASSIGNMENT SHEETS

Assignment Sheet #2

1.

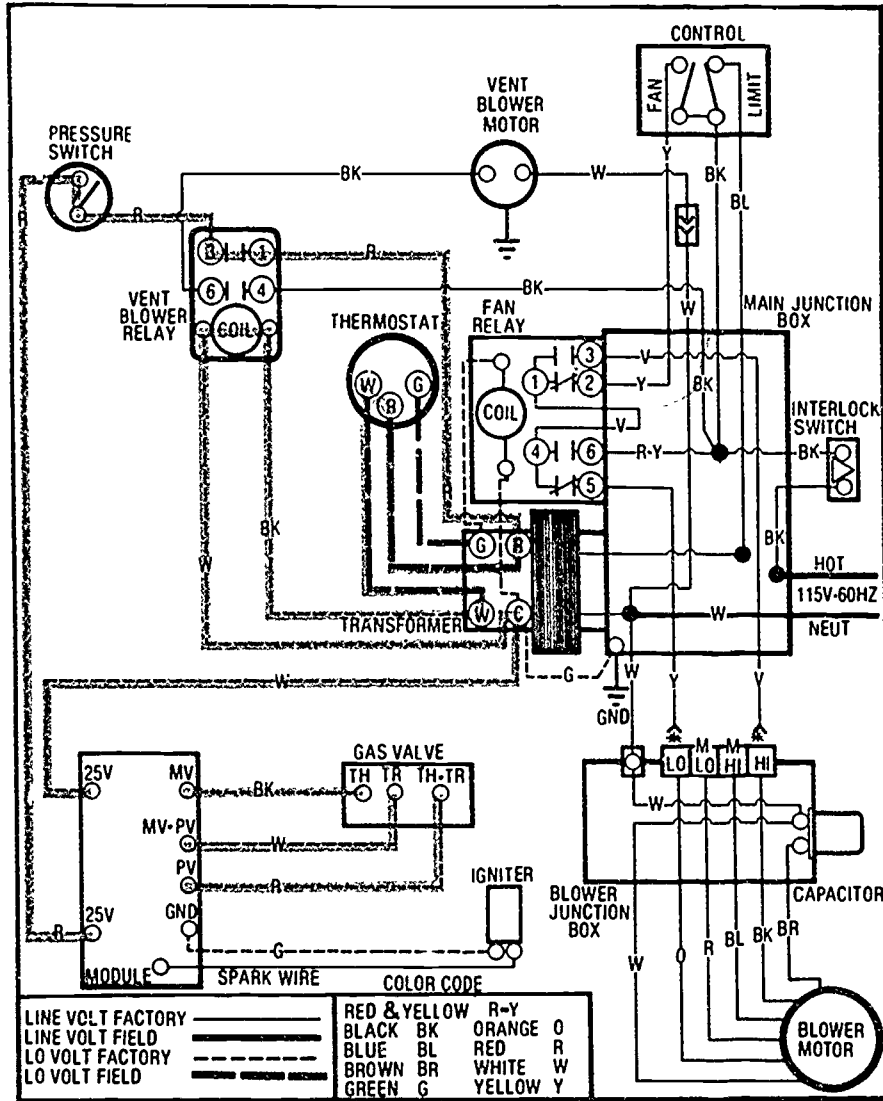

Courtesy Inter-City Products Corporation (USA)

ANSWERS TO ASSIGNMENT SHEETS

Assignment Sheet #2

2.

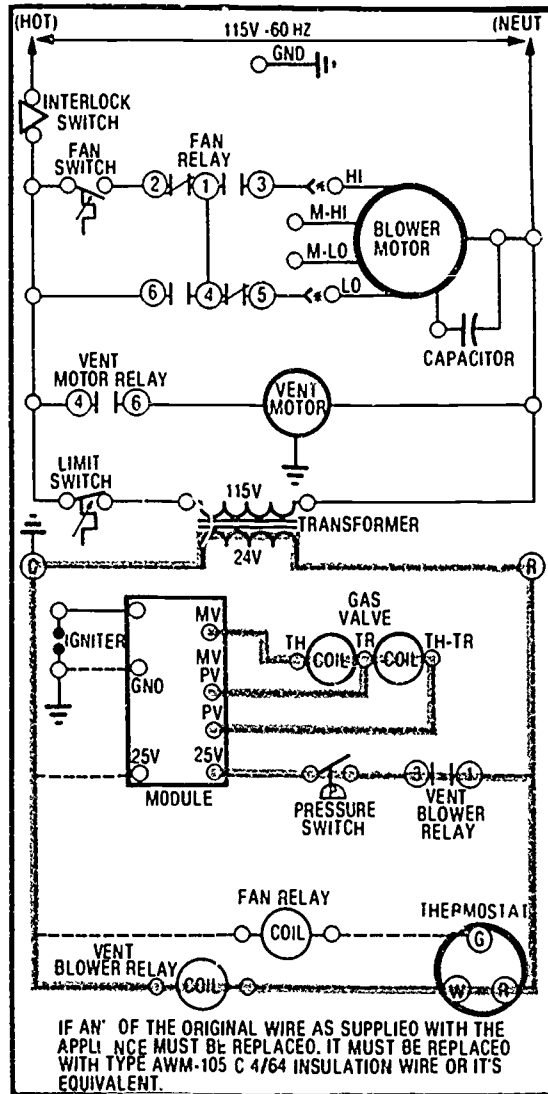

Courtesy Inter-City Products Corporation (USA)

HIGH-EFFICIENCY GAS-FIRED FURNACES UNIT X

JOB SHEET #1 — TROUBLESHOOT AN INDUCED DRAFT FURNACE ON A "NO HEAT" COMPLAINT

A. Tools and equipment

1. Induced draft furnace as selected by instructor
2. VOM
3. Service technician's tool pouch/box
4. Inclined manometer
5. Pencil and paper
6. Safety glasses

B. Procedure

1. Check the work area to make sure it is safe and put on safety glasses.
2. Check power source with voltmeter.
3. Set room thermostat above room temperature.
4. Check output of 24V transformer for voltage.
5. Check first to verify that the induced draft blower motor is running; if the blower is running,
6. Check across the contacts of the air pressure switch to verify that the switch is closed.
 - a. If you can read 24V across the contacts, the switch is open.
 - b. If you do not read 24V, the switch is okay.
7. Make another ohm check at the switch with the following procedure.

(NOTE: The voltage check is a quick check, but the ohm check will tell you if you have problems in front of the switch.)

 - a. Pull the leads off both sides of the pressure switch.
 - b. Take an ohm reading across the contacts to determine if the switch is open or closed.
 - c. No continuity means the switch is defective or that there may be a problem in the venting system.

JOB SHEET #1

- d. If there is continuity the switch is okay and the problem is elsewhere, but probably not in the venting system.
 - e. Replace leads on the switch.
8. Assume that you have an open switch and continue troubleshooting the venting system before condemning the switch.
 9. Turn the thermostat to the "off" position.
 10. Disconnect the hose or hoses at the pressure switch, and connect to your manometer.
 11. Connect your hose(s) as specified in manufacturer's switch operating pressure(s).
(NOTE: Check specifications carefully because some systems have one tube, some have two.)
 12. Compare your pressure reading with specifications.
 - a. If you come up with the proper pressure reading, the pressure switch is defective and must be replaced.
 - b. If you come up with an improper pressure reading, the pressure switch is probably okay and the problem may be in the venting system, maybe a bird's nest blocking the flue.

(NOTE: Finding a bird's nest in a flue is a common problem when first firing up a furnace in the fall.)
 13. Check the vent visually to make sure it is open.
 - a. If something is blocking the vent, remove it.
 - b. Once the vent is clear, take the pressure reading again.
 14. Disconnect the manometer and put the hose(s) back in place on the pressure switch.
 15. Make a test run to make sure the furnace is operating properly.
 - Have your instructor check your work
 16. Clean area and return tools and equipment to proper storage.

HIGH-EFFICIENCY GAS-FIRED FURNACES UNIT X

JOB SHEET #2—TROUBLESHOOT A CONDENSING FURNACE ON A "NO HEAT" COMPLAINT

A. Tools and equipment

1. Condensing furnace as selected by instructor
2. VCM
3. Service technician's tool pouch/box
4. Safety glasses /

B. Procedure

1. Check the work area to make sure it is safe and put on safety glasses.
 2. Follow the usual routine for verifying that all limit switches are closed, that 24V is available from the transformer, and that the vent pressure switch is functioning properly.
 3. Trace the circuitry to the condensing drain trap assembly.

(NOTE: If preliminary troubleshooting has not isolated the problem, checking for a clogged drain that is causing the overflow protector switch to open is a routine unique to some condensate furnaces.)
 4. Disconnect the leads to the overflow protector switch.
 5. Make an ohm check across the switch.
 - a. If there is continuity, the trouble is elsewhere.
 - b. If there is no continuity, the switch is either defective or the drain is plugged up.
 6. Check the drain to make sure it is free of obstructions.
 - a. If the drain is free of obstruction, the switch is defective and should be replaced.
 - b. If the drain is obstructed, clean the drain to correct the problem.
- Have your instructor check your work
7. Run furnace to verify proper operation.
 8. Clean area and return tools and materials to storage.

**HIGH-EFFICIENCY GAS-FIRED FURNACES
UNIT X**

PRACTICAL TEST #1

**JOB SHEET #1 — TROUBLESHOOT AN INDUCED DRAFT
FURNACE ON A "NO HEAT" COMPLAINT**

Student's name _____ Date _____

Evaluator's name _____ Attempt no. _____

Student instructions: When you are ready to perform this task, ask your instructor to observe the procedure and complete this form. All items listed under "Process Evaluation" must receive a "yes" for you to receive an overall performance evaluation.

PROCESS EVALUATION

(EVALUATOR NOTE: Place a check mark in the "Yes" or "No" blanks to designate whether or not the student has satisfactorily achieved each step in this procedure. If the student is unable to achieve this competency, have the student review the materials and try again.)

The student:	YES	NO
1. Checked power source.	<input type="checkbox"/>	<input type="checkbox"/>
2. Checked output of 24V transformer.	<input type="checkbox"/>	<input type="checkbox"/>
3. Checked induced draft blower motor.	<input type="checkbox"/>	<input type="checkbox"/>
4. Checked voltage across air pressure switch.	<input type="checkbox"/>	<input type="checkbox"/>
5. Made ohm check of air pressure switch.	<input type="checkbox"/>	<input type="checkbox"/>
6. Checked switch operating pressure with manometer.	<input type="checkbox"/>	<input type="checkbox"/>
7. Checked vent for blockage.	<input type="checkbox"/>	<input type="checkbox"/>
8. Verified proper furnace operation.	<input type="checkbox"/>	<input type="checkbox"/>

Evaluator's comments: _____

JOB SHEET #1 PRACTICAL TEST

PRODUCT EVALUATION

(EVALUATOR NOTE: Rate the student on the following criteria by circling the appropriate numbers. Each item must be rated at least a "3" for mastery to be demonstrated. (See performance evaluation key below.) If the student is unable to demonstrate mastery, student materials should be reviewed and another test procedure must be submitted for evaluation.)

Criteria:

Power and transformer checks	4	3	2	1
Voltage and ohm checks	4	3	2	1
Pressure check with manometer	4	3	2	1
Workplace Safety	4	3	2	1

EVALUATOR'S COMMENTS: _____

PERFORMANCE EVALUATION KEY

- 4 — **Skilled** — Can perform job with no additional training.
- 3 — **Moderately skilled** — Has performed job during training program; limited additional training may be required.
- 2 — **Limited skill** — Has performed job during training program; additional training is required to develop skill.
- 1 — **Unskilled** — Is familiar with process, but is unable to perform job.

(EVALUATOR NOTE: If an average score is needed to coincide with a competency profile, total the designated points in "Product Evaluation" and divide by the total number of criteria.)

HIGH-EFFICIENCY GAS-FIRED FURNACES UNIT X

PRACTICAL TEST #2

JOB SHEET #2 — TROUBLESHOOT A CONDENSING FURNACE ON A "NO HEAT" COMPLAINT

Student's name _____ Date _____

Evaluator's name _____ Attempt no. _____

Student instructions: When you are ready to perform this task, ask you instructor to observe the procedure and complete this form. All items listed under "Process Evaluation" must receive a "yes" for you to receive an overall performance evaluation.

PROCESS EVALUATION

(EVALUATOR NOTE: Place a check mark in the "Yes" or "No" blanks to designate whether or not the student has satisfactorily achieved each step in this procedure. If the student is unable to achieve this competency, have the student review the materials and try again.)

The student:	YES	NO
1. Made checks on limit switches and transformer.	<input type="checkbox"/>	<input type="checkbox"/>
2. Checked vent pressure switch.	<input type="checkbox"/>	<input type="checkbox"/>
3. Traced circuitry to condensing drain trap assembly.	<input type="checkbox"/>	<input type="checkbox"/>
4. Made ohm check across overflow switch protector.	<input type="checkbox"/>	<input type="checkbox"/>
5. Checked drain for obstructions.	<input type="checkbox"/>	<input type="checkbox"/>
6. Verified system operation.	<input type="checkbox"/>	<input type="checkbox"/>

Evaluator's comments: _____

JOB SHEET #2 PRACTICAL TEST

PRODUCT EVALUATION

(EVALUATOR NOTE: Rate the student on the following criteria by circling the appropriate numbers. Each item must be rated at least a "3" for mastery to be demonstrated. (See performance evaluation key below.) If the student is unable to demonstrate mastery, student materials should be reviewed and another test procedure must be submitted for evaluation.)

Criteria:

Limit switch, transformer, and vent switch checks	4	3	2	1
Trace of drain trap circuitry	4	3	2	1
Ohm check of overflow switch	4	3	2	1
Drain check and system verification	4	3	2	1

EVALUATOR'S COMMENTS: _____

PERFORMANCE EVALUATION KEY

- 4 — **Skilled** — Can perform job with no additional training.
- 3 — **Moderately skilled** — Has performed job during training program; limited additional training may be required.
- 2 — **Limited skill** — Has performed job during training program; additional training is required to develop skill.
- 1 — **Unskilled** — Is familiar with process, but is unable to perform job.

(EVALUATOR NOTE: If an average score is needed to coincide with a competency profile, total the designated points in "Product Evaluation" and divide by the total number of criteria.)

HIGH-EFFICIENCY GAS-FIRED FURNACES UNIT X

TEST

NAME _____ SCORE _____

1. Match the terms on the right with their correct definitions.

- | | |
|--|------------------------------------|
| <p>_____ a. A furnace that extracts heat from flue products to conserve energy, and produces condensate that has to be drained off</p> | <p>1. Purge cycle</p> |
| <p>_____ b. A high-efficiency furnace that uses a cycle of positive and negative pressures to ignite gas/air mixtures in cycles of 60 to 70 times per second</p> | <p>2. Secondary heat exchanger</p> |
| <p>_____ c. An additional heat exchanger that flue products pass through before being vented outdoors</p> | <p>3. Air sensing switch</p> |
| <p>_____ d. A small blower used on some furnaces to supply combustion air</p> | <p>4. Condensing furnace</p> |
| <p>_____ e. The movement of air through a heat exchanger prior to combustion to get rid of unburned fuel and assure a smooth ignition</p> | <p>5. Combustion air blower</p> |
| <p>_____ f. A circuit built into electronic ignition devices that automatically shuts down the entire system if ignition does not occur after a limited number of attempts</p> | <p>6. Lockout</p> |
| <p>_____ g. A switch operated by air pressure to determine if a furnace is properly venting</p> | <p>7. Pulse furnace</p> |
| <p>_____ h. A furnace that uses a special blower to control combustion air and the rate combustion gases are vented</p> | <p>8. Induced draft furnace</p> |

2. Select true statements concerning induced draft furnaces. Place an "X" beside each true statement.

- _____ a. Induced draft furnaces accomplish high-efficiency performance by controlling the amount of fuel used for combustion.
- _____ b. Combustion is controlled with an induced draft blower which controls the rate combustion gases are released up the flue.
- _____ c. An induced draft furnace has very few of the same components as a standard gas-fired furnace with automatic ignition.

TEST

- _____ d. Induced draft furnaces have two components not found on standard furnaces, the induced draft blower and an air sensing switch.
- _____ e. The air sensing switch monitors the system for proper venting and shuts the system down if there are problems.
3. Complete statements concerning condensing furnaces. Circle the material that best completes each statement.
- Condensing furnaces accomplish high-efficiency performance by passing hot flue gases through a secondary heat exchanger to take advantage of heat that would otherwise be (vented) (condensed).
 - In the process of condensing flue gases, condensate forms as part of the heat removal process, and the condensate has to be (drained away) (vented).
 - In cases where a condensing furnace is not located near a drain, a (small pump) (special pump) may be required to pump the condensate to a proper point of discharge.
 - A condensing furnace is similar to an induced draft furnace except that it has a secondary heat exchanger which is usually made of (stainless steel) (cast iron).
 - A condensing furnace is similar to an induced draft furnace because it has an air sensing switch, but the condensing furnace also has a second heat exchanger and a (condensate drain trap) (special control) assembly.
 - Condensing furnaces are generally regarded as being the most efficient of high-efficiency furnaces and their ratings can run as high as (97% to 98%) (90% to 95%).
4. Complete statements concerning pulse furnaces. Circle the material that best completes each statement.
- In a pulse furnace, a spark is used to ignite a gas/air mixture to begin the cycle, but ignition for later combustion is the product of (back pressure) (negative) ignition.
 - Some pulse furnaces are actually (condensing) (induced draft) furnaces that use the pulse combustion process.
 - In a pulse furnace, the initial combustion takes place in an enclosed chamber, then, as combustion products pass through the heat exchanger system into a coil, the latent heat is extracted by condensing water from the (exhaust gas) (main heat exchanger).

TEST

- d. Pulse furnaces use a small blower to purge the combustion chamber before and after each heating cycle to provide proper air mixture for (start-up) (continuous combustion).
- e. Pulse furnaces use a (redundant gas) (single gas) valve to assure safe shut-off, there is another sensor that verifies loss of combustion and will shut the system down, and obstructions to the air intake or outlet will also shut the system down.
5. Select true statements concerning safety with high-efficiency furnaces. Place an "X" beside each true statement.
- ____ a. Flue gas temperature on condensing furnaces is so low that a vent going through an unconditioned space should be insulated to keep vent vapor from freezing and blocking the vent.
- ____ b. Combustion air for some condensing furnaces can be taken directly from outside and help avoid problems with indoor contaminants such as aerosols and cleaning agents.
- ____ c. Pulse furnaces produce a combustion vibration that requires special attention during installation.
- ____ d. All high-efficiency furnaces should be probably oversized.
6. Solve problems concerning maintaining and servicing high-efficiency furnaces. Select the best solution to each of the following problems.
- a. You've been directed to service a "no heat" complaint for a customer who has a pulse furnace. Your best approach to service is what? _____.
- 1) Immediately check venting because that's the source of most pulse furnace problems.
 - 2) Check the 24V power source first.
 - 3) Do as little disassembly as possible to avoid creating new problems.
- b. On a service call for a condensing furnace you find evidence of soot and other flue products in the secondary heat exchanger. You know immediately that one of the problems will definitely be what? _____.
- 1) Improper venting.
 - 2) Improper gas supply.
 - 3) Improper combustion.

TEST

- c. On a service call for a "poor performance" complaint on an induced draft furnace, you immediately notice a dirty filter. What do you tell the customer?
_____.
- 1) Change the filter yourself and save money.
 - 2) A dirty filter can greatly diminish furnace efficiency, so check the filter often and replace when needed.
 - 3) That a dirty filter can be brushed clean and used again.

(NOTE: If the following activities have not been accomplished prior to the test, ask your instructor when they should be completed.)

7. Trace the high voltage circuitry for an induced draft furnace. (Assignment Sheet #1)
8. Trace the low voltage circuitry for an induced draft furnace. (Assignment Sheet #2)
9. Demonstrate the ability to:
 - a. Troubleshoot an induced draft furnace on a "no heat" complaint. (Job Sheet #1)
 - b. Troubleshoot a condensing furnace on a "no heat" complaint. (Job Sheet #2)

**HIGH-EFFICIENCY GAS-FIRED FURNACES
UNIT X****ANSWERS TO TEST**

1. a. 4 e. 1
 b. 7 f. 6
 c. 2 g. 3
 d. 5 h. 8

2. b, d, e

3. a. Vented
 b. Drained away
 c. Small pump
 d. Stainless steel
 e. Condensate drain trap
 f. 97% to 98%

4. a. Back pressure
 b. Condensing
 c. Exhaust gas
 d. Start-up
 e. Redundant gas

5. a, b, c

6. a. 3)
 b. 3)
 c. 2)

7. Evaluated according to assignment sheet answers

8. Evaluated according to assignment sheet answers

9. a. Evaluated according to criteria in Practical Test #1.
 b. Evaluated according to criteria in Practical Test #2.



OIL-FIRED FURNACES UNIT XI

UNIT OBJECTIVE

After completion of this unit, the student should be able to install and service an oil-fired furnace. These competencies will be demonstrated by completing the job sheets and by scoring a minimum of 85 percent on the unit test.

SPECIFIC OBJECTIVES

After completion of this unit, the student should be able to:

1. Match terms related to oil-fired furnaces with their definitions.
2. Match oil furnace types with their performance characteristics.
3. Solve problems concerning oil storage tanks.
4. Identify the major components of an oil burner assembly.
5. Complete statements concerning the operation of a gun type atomizing burner.
6. Solve problems concerning flame retention.
7. Select true statements concerning visual flame detection and cad cell location.
8. Complete statements concerning troubleshooting cad cell systems.
9. Complete statements concerning combustion chambers.
10. Select true statements concerning fuel pumps.
11. Select true statements concerning nozzles.
12. Solve problems concerning nozzle service guidelines.
13. Complete statements concerning venting.
14. Select true statements concerning normal operating sequence.
15. Solve problems concerning electrodes.
16. Complete statements concerning combustion testing.

OBJECTIVES SHEET

17. Match burner components with required maintenance.
18. Demonstrate the ability to:
 - a. Install an oil-fired furnace. (Job Sheet #1)
 - b. Perform a stack temperature test on an oil-fired furnace. (Job Sheet #2)
 - c. Perform a CO₂ test and determine the combustion efficiency of an oil-fired furnace. (Job Sheet #3)
 - d. Perform a smoke test on an oil-fired furnace. (Job Sheet #4)
 - e. Perform an "overfire draft" and a "flue draft" test on an oil-fired furnace. (Job Sheet #5)
 - f. Perform fuel pump service on an oil-fired furnace. (Job Sheet #6)

**OIL-FIRED FURNACES
UNIT XI****SUGGESTED ACTIVITIES**

- A. Obtain additional materials and/or invite resource people to class to supplement/reinforce information provided in this unit of instruction.

(NOTE: This activity should be completed prior to the teaching of this unit.)

- B. Make transparencies from the transparency masters included with this unit.
- C. Provide students with objective sheet.
- D. Discuss unit and specific objectives.
- E. Provide students with information sheets.
- F. Discuss information sheets.

(NOTE: Use the transparencies as needed to enhance the information.)

- G. Provide students with job sheets.
- H. Discuss and demonstrate the procedures outlined in the job sheets.
- I. Integrate the following activities throughout the teaching of this unit:
1. Invite a factory representative to discuss oil-fired furnaces with your class members.
 2. Show the students a pump/electrode assembly and point out how the nozzle/electrode relationship is important to proper combustion.
 3. Demonstrate the proper use of instruments for combustion testing such as a draft gauge, CO₂ analyzer, smoke tester, and stack thermometer.
 4. Meet individually with students to evaluate their progress through this unit of instruction, and indicate to them possible areas for improvement.
- J. Give test.
- K. Evaluate test.
- L. Reteach if necessary.

SUGGESTED ACTIVITIES

REFERENCES USED IN WRITING THIS UNIT

- A. Althouse, Andrew D., and Carl H. Turnquist and Alfred C. Bracciano. *Modern Refrigeration and Air Conditioning*, South Holland, IL: The Goodheart-Wilcox Company, Inc., 1988.
- B. Air Conditioning and Refrigeration Institute, *Refrigeration and Air Conditioning*, Second edition, Arlington, VA: Prentice-Hall 1987.
- C. Yates, David, *Oil Furnace Installation and Service*. Lavergne, TN: Heil-Quaker Corporation, no date.
- D. "Becket Equipment Catalog." Elyria, OH 44036: R. W. Beckett Corporation, 1990.
- E. "Oil Burner Combustion Testing, Bulletin 4011." Pittsburg, PA 15238-2878: Bacharach, Inc., 1989.

**OIL-FIRED FURNACES
UNIT XI****INFORMATION SHEET****I. Terms and definitions**

- A. **Breeching** — The flue outlet to which the stack or flue pipe is connected
- B. **Cadmium cell** — A device whose electrical resistance decreases in the presence of light
- C. **Chimney effect** — The tendency for heated air to rise in a duct or other vertical air passage
- D. **Electrode** — A conductor having a high heat resistance, used to form the spark gap for an oil burner ignition system
- E. **High-pressure atomizing burner** — An oil burner using a high-pressure pump and nozzle to break the oil into a fine spray
- F. **Fuel oil** — Domestic heating oil classified as #1 for outdoor storage tanks and #2 for indoor storage tanks
- G. **Nozzle** — The small fitting on the nose of a gun type oil burner which regulates the flow of oil and breaks the oil into a fine spray
- H. **Stack switch** — A device to sense flue gas temperature on oil-burning equipment; activates the primary control safety circuit in the event of flame failure
- I. **Stack temperature** — The temperature of the flue gases taken at a point between the breeching and the draft regulator
- J. **Combustion chamber** — The combustion area of the primary section of the heat exchanger that has a fire-resistant liner
- K. **Coke trees** — A reference to the build up of carbon on the surface of the combustion chamber
- L. **Draft regulator** — A device in the vent to maintain a stable or fixed draft through the heating equipment within the limits of available draft of the chimney
- M. **Primary control** — A device that supervises starting, running, stopping, and emergency shut-down of an oil-fired burner

INFORMATION SHEET

II. Oil furnace types and performance characteristics

- A. Upflow — Air flows upward through the furnace (Transparency 1)
 - 1. Standard — Blower located below the heat exchanger
 - 2. Low-boy — Blower located behind the heat exchanger
- B. Counterflow — Air flows downward through the furnace with the blower above the heat exchanger (Transparency 2)
- C. Horizontal — Air flows through the furnace from one end to the other (Transparency 3)
- D. Floor furnace — Installed flush with the floor to provide gravity heat (Transparency 4)

III. Oil storage tanks (Handout #1)

- A. Locations
 - 1. In a basement or crawl space
 - 2. In a garage, shed or similar outbuilding
 - 3. Outdoors, above ground
 - 4. Outdoors, below ground
- B. Types of tanks
 - 1. Indoor — Usually a welded, 14-gauge steel, obround tank
 - 2. Outdoor — Must be of heavy gauge steel and should be protected with a rust-resistant paint
- C. Types of feed systems
 - 1. Gravity feed — Bottom of the tank must be level with a specified distance above the intake of the oil burner; uses one oil line between the tank and burner.
 - 2. Forced feed — Used when the tank bottom must be lower than the specified distance above the intake of the oil burner or the tank has to be at some distant location; uses two lines, a supply and return.

(NOTE: Manufacturers installation instructions and local code requirements are to be followed.)

INFORMATION SHEET

IV. Major components of an oil burner assembly (Transparency 5)

- A. Motor — drives the blower and fuel pump
- B. Fuel pump — pumps fuel from storage tank to nozzle
- C. Ignition transformer — provides high voltage (approximately 10,000 AC volts) to spark electrodes
- D. Blower — provides primary air for combustion
- E. Nozzle — atomizes the fuel oil
- F. Ignition electrodes — ignites the fuel air mixture

V. Operation of gun-type atomizing burner (Figure 1)

- A. Fuel pump delivers oil under pressure (100 to 125 pounds per square inch) to a precision made nozzle.
- B. The oil is broken up at the nozzle into a fine, cone-shaped mist.
- C. The pump motor also drives a blower which supplies a turbulent stream of air to the burner at the point where the nozzle is spraying oil.
- D. The atomized mixture is readily ignited by an electric spark supplied by an ignition transformer through an ignition electrode assembly.

FIGURE 1

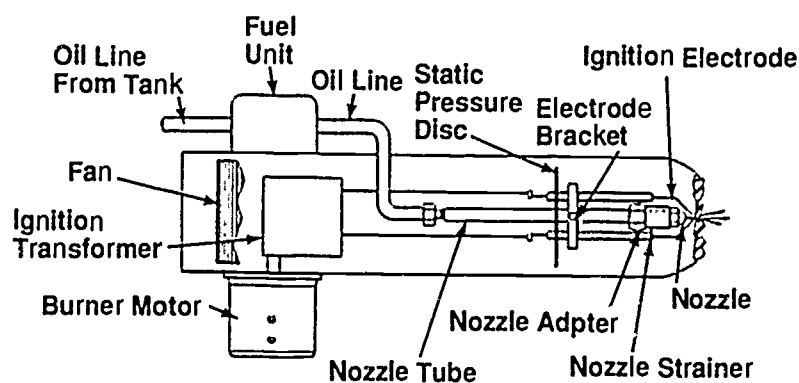

Courtesy Inter-City Products Corporation (USA)

INFORMATION SHEET

VI. Flame retention

- A. Used to describe the principles of fuel combustion in a manner whereby the size and shape of the flame is principally determined by the burner head assembly
- B. Flame retention burners
1. Require no support for combustion such as a chamber.
 2. Require that a relatively high pressure drop of the combustion air occur at the burner head.
 3. The pressure drop is created in a way that will cause a high velocity rotating motion to the combustion air as it exits the head.
 4. The high velocity air mixes with the atomized oil in a small zone directly in front of the burner head.
 5. This method of mixing air and oil greatly reduces the variation in fuel-air ratios.
 6. Results in establishing a stable flame form with reduced oscillating motion. (Figure 2)

FIGURE 2

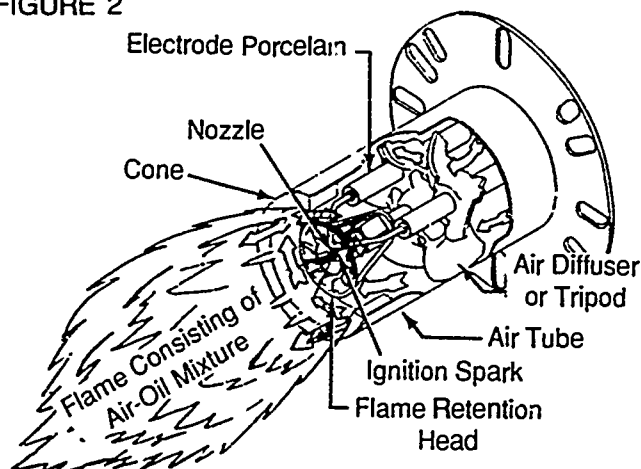

Courtesy Inter-City Products Corporation (USA)

7. Combustion volume is greatly reduced.
8. Combustion temperatures are higher.
9. Problems created by variations in stack draft are reduced.

INFORMATION SHEET

C. Advantages

1. Savings in fuel consumption
2. Fewer pollutants given off
3. Less burner maintenance
4. Better overall performance

VII. Visual flame detection and cad cell location (Transparency 6)

A. Basic primary control functions

1. Responds to requirements from the thermostat
2. Shuts the burners off on limit action
3. Supervises burner operation
4. Proves the flame
5. Controls the ignition and oil valve
6. Shuts down on a system malfunction

B. Cad cell location

1. Is a critical factor in performance of the cad cell
2. Must be mounted in the burner where it has a direct open line of sight to the flame in order to "see" the oil flame
3. Usually mounted in the rear of the burner to be protected from excessive heat
4. Since cad cell resistance decreases in the presence of light, adequate light must reach the cell.
5. Light, not heat makes the cad cell work and ambient temperatures must be below 140°F.
6. The cell must be protected from external light and must have adequate clearance from metal surfaces that could cause shielding or heat radiation.

INFORMATION SHEET

C. Cad cell operation

1. Cad cell monitors the light given off by the flame. (Figure 3)

FIGURE 3

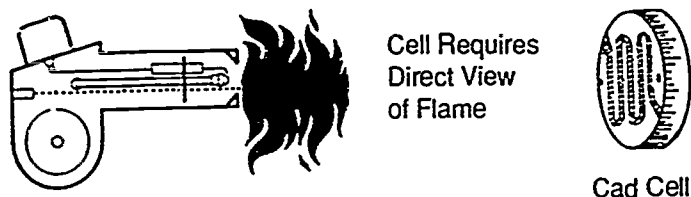

Courtesy Inter-City Products Corporation (USA)

2. Resistance increases when there is no light (flame).
3. Resistance decreases in the presence of light (flame).

VIII. Troubleshooting cad cell systems (Transparency 7)

- A. Check out the light cell with the following procedure:
 1. Remove cad cell lead wires from the primary control.
 2. Start the burner and then jumper the main primary control terminals to permit the burner to run.
 3. Connect cad cell lead wires to the ohmmeter and look for a reading of less than 1600 ohms.
- B. Check out the dark cell with the following procedure:
 1. Stop the burner and remove the jumper from the main primary control terminals.
 2. Leave cad cell lead wires connected to ohmmeter and look for a reading of 100,000 ohms or more.
- C. Always check the cad cell when it appears there is an open circuit in the flame detector circuit.
- D. Vibration can cause a cad cell to move out of place so always check for proper seating

INFORMATION SHEET

- E. There is little actual service that can be done on the cad cell itself, but the face of the cell can be cleaned to make sure the electrode and conductive grid are free of build-up. (Figure 4)

FIGURE 4

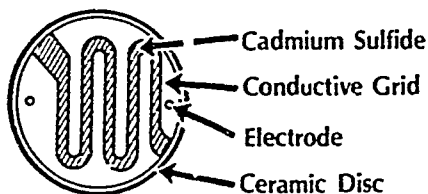

Courtesy Inter-City Products Corporation (USA)

IX. Combustion chambers (Figure 5)

A. Function

1. Surround the flame.
2. Radiate heat back into the flame to aid in combustion.

B. Design

1. Must be made of the correct material.
2. Must be properly sized for the nozzle firing rate.
3. Must be shaped correctly.
4. Must be the proper height.

C. Requirements

1. Has to withstand intense heat.
2. Must heat up quickly.

INFORMATION SHEET

FIGURE 5

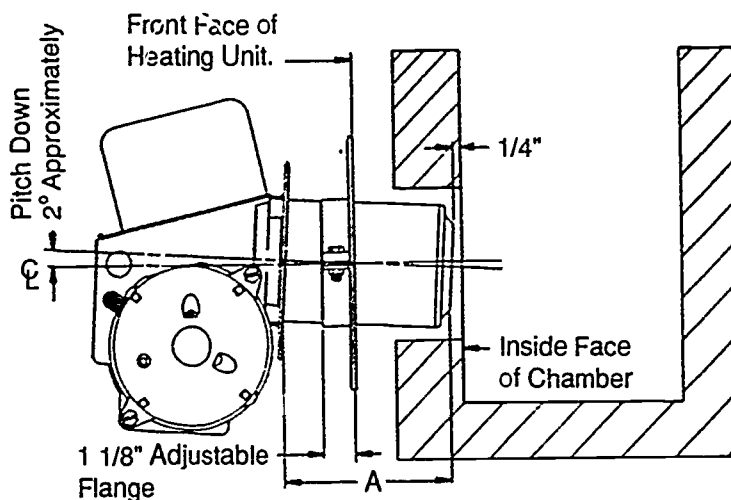

(NOTE: The air tube length shown as Diameter A is the distance from the front of the air tube retainer flange to the face of the air cone. The angle of the oil burner keeps any oil flow at the fire end of the air tube after shut off.)

Courtesy Inter-City Products Corporation (USA)

X. Fuel pumps (Transparencies 8 and 9)

- A. A fuel pump is either a single-stage or two-stage unit.
- B. A single-stage fuel pump has only one set of gears.
- C. A single-stage unit is usually used where the supply tank is above the burner.
- D. The single-stage unit draws oil from the tank directly and delivers it to the nozzle under sufficient pressure to properly atomize the oil for combustion.
- E. A two-stage fuel pump has two sets of gears.
- F. The suction gears in a two-stage pump draw oil from a submerged tank or a tank located below the level of the oil burner.
- G. The pressure gearset delivers oil under pressure to the burner nozzle.
- H. Since the pressure gearset does not have to do any lifting to supply the oil, it can totally dedicate its service to properly atomizing the fuel.

INFORMATION SHEET

XI. Nozzles

- A. Nozzles in general are rated as Type A nozzles which produce a hollow spray pattern or Type B which produce a solid spray pattern. (Figure 6)

FIGURE 6

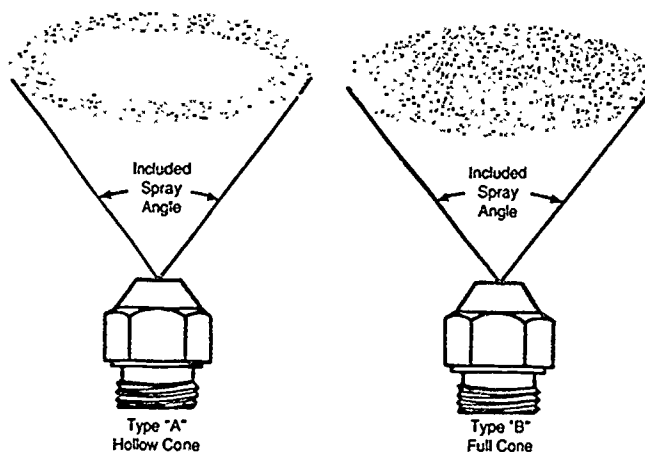

Courtesy Inter-City Products Corporation (USA)

- B. Nozzles are rated in gallons per hour and the spray angle is stamped on the nozzle. (Figure 7)

FIGURE 7

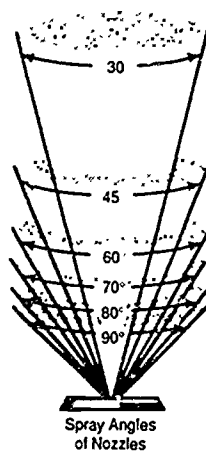

Courtesy Inter-City Products Corporation (USA)

INFORMATION SHEET

- C. The hollow air pattern produces a hollow air spray with no measurable air velocity at the center of the pattern. (Figure 8)

FIGURE 8

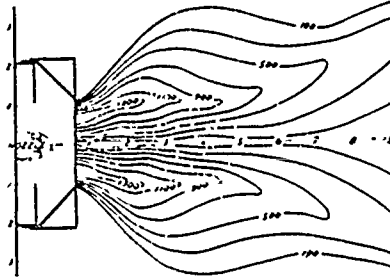

Courtesy Inter-City Products Corporation (USA)

- D. The solid air pattern produces a moderate solid air spray with definite measurable air velocity at the center of the pattern. (Figure 9)

FIGURE 9

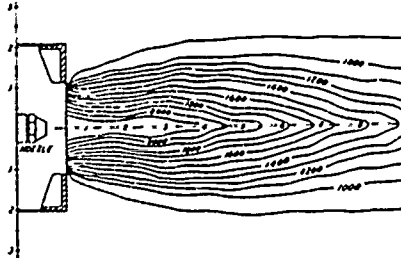

Courtesy Inter-City Products Corporation (USA)

- E. For burners with flow rates up to 2.00 gph hollow cone nozzles can be used successfully, and on smaller burners, the hollow cone nozzles give the quietest service.

(NOTE: Nozzle selection will vary with the system and the guidelines presented here are for general applications.)

- F. For burners with flow rates between 2.00 and 3.00 gph, either a hollow cone or solid cone nozzle can be used depending on burner air pattern.
- G. For burners with flow rates above 3.00 gph, solid cone nozzles usually produce smoother ignition at higher flow rates, but some systems do use hollow cone nozzles.

INFORMATION SHEET**XII. Nozzle service guidelines**

- A. Air in the lines is the primary cause of oil drip, but it can also be caused by high nozzle temperature.
- B. Hot nozzles are caused by expanding hot oil that cannot go back to the pump so it expands out through the nozzle orifice.
- C. Hot nozzle problems are frequently caused by lack of draft, down drafts, the end of the burner tube is inserted too far into the chamber, or there is high CO₂ and smoke because of a misadjusted burner.

(NOTE: On a conventional installation, be sure the end of the burner tube is flush with the inside wall of the combustion chamber to prevent the nozzle from overheating.)

- D. Nozzles should be replaced each year at the beginning of the heating season.

(NOTE: Cleaning nozzles is not recommended because they are too easy to damage and too time consuming, and although nozzles can last longer than one season, yearly replacement assures the best system performance.)

- E. Keep nozzles in their original containers until installation, and handle nozzles with proper tools so you don't risk touching one with greasy hands.
- F. Never disassemble a nozzle before installation because great care has been taken to make sure it is absolutely clean on delivery.
- G. When servicing a nozzle, work with clean tools which include a pressure gauge, a vacuum gauge, a nozzle changer, and a flame inspection mirror.
- H. Flush the nozzle line before installing a new nozzle.
- I. Never blow into a nozzle or stick a pin into a nozzle orifice to clean it.

XIII. Venting

- A. Must convey hot combustion gases to the outside.
- B. Must protect the structure from fire hazards due to overheating
- C. Must prevent the escape of combustion gases into the occupied space.
- D. Must be made of material approved for an oil-fired furnace.

XIV. Normal operating sequence

- A. Thermostat calls for heat.
- B. Current flows to the burner motor and ignition transformer.
- C. A current flow exists through the dark cell and the safety switch heater.

INFORMATION SHEET

- D. Immediately, the ignition transformer establishes a spark (approx. 1/8" long) across the electrodes by the nozzle.
- E. The oil burner blower reaches full speed, blowing the spark forward igniting the oil spray quickly expanding into a full burst of fire in the combustion chamber.
- F. Light from the flame reaches the cad cell and prevents the safety from opening.
- G. Flame efficiency increases as the combustion chamber temperature rises, reaching a white-hot surface temperature when the burner is operating at peak efficiency.
- H. Thermostat is satisfied.
- I. Current flow is interrupted.
- J. Operation ceases with the exception of the furnace air circulating blower motor which will stop after residual heat is dissipated.

XV. Electrodes

- A. Electrode settings have three different parameters:
 1. Parameter A is the gap between the electrodes as they are centered over the nozzle.
 2. Parameter B is the height the electrodes are distanced from the center of the nozzle.
 3. Parameter C is the distance the electrodes extend in front of the nozzle. (Figure 10)

FIGURE 10

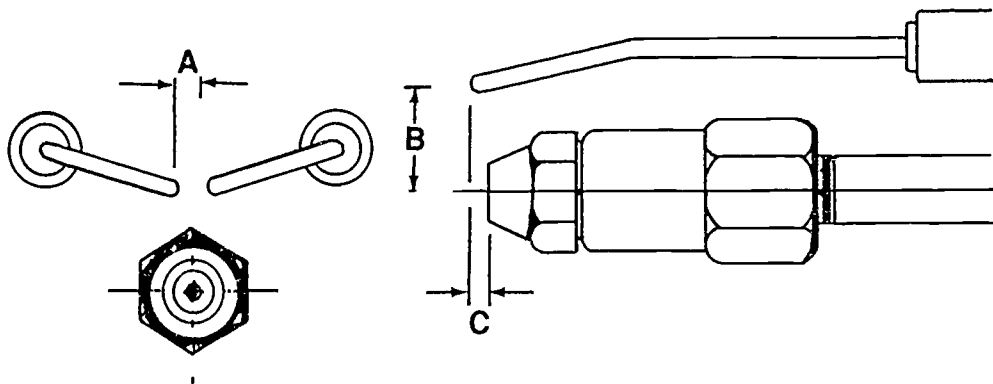

Courtesy Inter-City Products Corporation (USA)

INFORMATION SHEET

- B. In all cases, electrode settings are determined by the degrees of the nozzle spray pattern.

Nozzle	GPH	A	B	C
45°	(.75 to 4.00)	1/8 to 3/16	1/2" to 9/16"	1/4"
60°	(.75 to 4.00)	1/8 to 3/16	9/16" to 5/8"	1/4"
60°	(.75 to 4.00)	1/8 to 3/16	9/16" to 5/8"	1/8"
80°	(.75 to 4.00)	1/8 to 3/16	9/16" to 5/8"	1/4"
90°	(.75 to 4.00)	1/8 to 3/16	9/16" to 5/8"	0

Courtesy Hell-Quaker Corporation

- C. When servicing electrodes always check for proper settings and use settings specified by the manufacturer.
- D. Check the electrode insulators for cracks or for a coat of soot or oil that can cause erratic conducting.
- E. Cracks under electrode brackets can cause short circuits and need to be checked.

XVI. Combustion testing (Transparency 10)

- A. Combustion testing determines if a furnace is operating properly and efficiently.
- B. Good combustion testing requires the proper instruments, recording test results, and comparing results with manufacturer's specifications. (Figure 11)

FIGURE 11 Combustion Testing Instruments



Courtesy Becharach, Inc.

INFORMATION SHEET

- C. The overfire draft test requires a draft gauge to read the draft over the fire just beyond the inner edge of the combustion chamber. (Figure 12)

FIGURE 12 Draft Gauge



Courtesy Bacharach, Inc.

- D. The stack draft requires a draft gauge to measure the draft ahead of the draft regulator.

INFORMATION SHEET

- E. The percent CO₂ test requires a CO₂ analyzer to obtain an air sample far enough ahead of the draft control to assure no outside air is mixed with it. (Figure 13)

FIGURE 13 CO₂ Analyzer



Courtesy Becharach, Inc.

- F. The smoke test requires a smoke tester to take a vent sample just ahead of the draft regulator. (Figure 14)

FIGURE 14 Smoke Tester



Courtesy Becharach, Inc.

INFORMATION SHEET

- G. The stack temperature measurement should be made in the vent just ahead of the draft regulator, and the thermometer needs to be of special design so it can reach into the center third of the flue pipe diameter. (Figure 15)

FIGURE 15

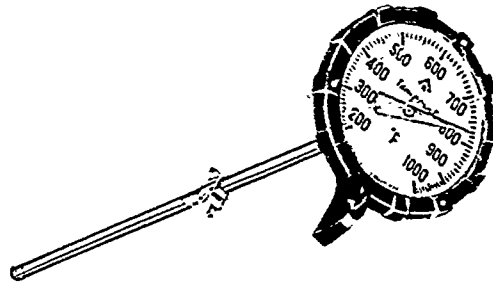

Courtesy Bacharach, Inc.

- H. The temperature rise measurement requires taking a measurement of supply air temperature with a regular service thermometer at a point close to the furnace, then subtracting that ambient temperature from the stack temperature.
- I. Combustion efficiency requires complete combustion testing, and charts or hand-held slide rules should be used to determine the percent efficiency. (Figure 16)

FIGURE 16 Hand-Held Efficiency Finder

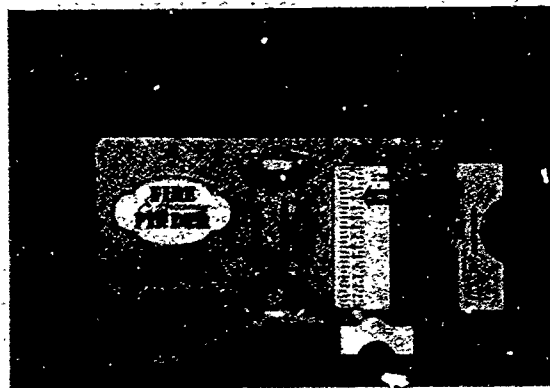

Courtesy: Bacharach, Inc.

XVII. Burner components and required maintenance

- A. Motor — Should be oiled twice a year.
- B. Filter — Oil filter cartridge should be replaced each year.
- C. Nozzle — Should be changed before start up of each heating season.
- D. Electrode settings — Should be checked once a year.

INFORMATION SHEET

- E. Blower — Must be kept free of dirt and lint.
- F. Replacements — Always use parts recommended by the manufacturer.

Upflow Furnace

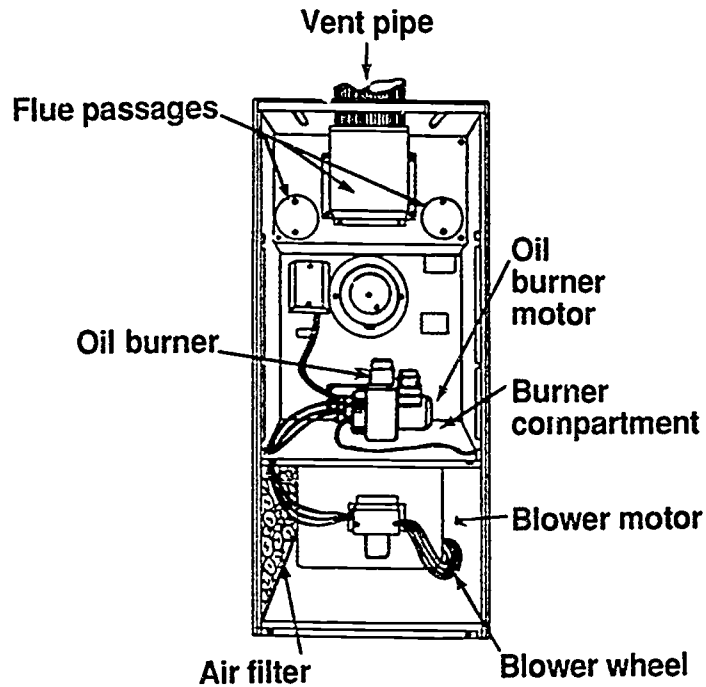

Typical Installation

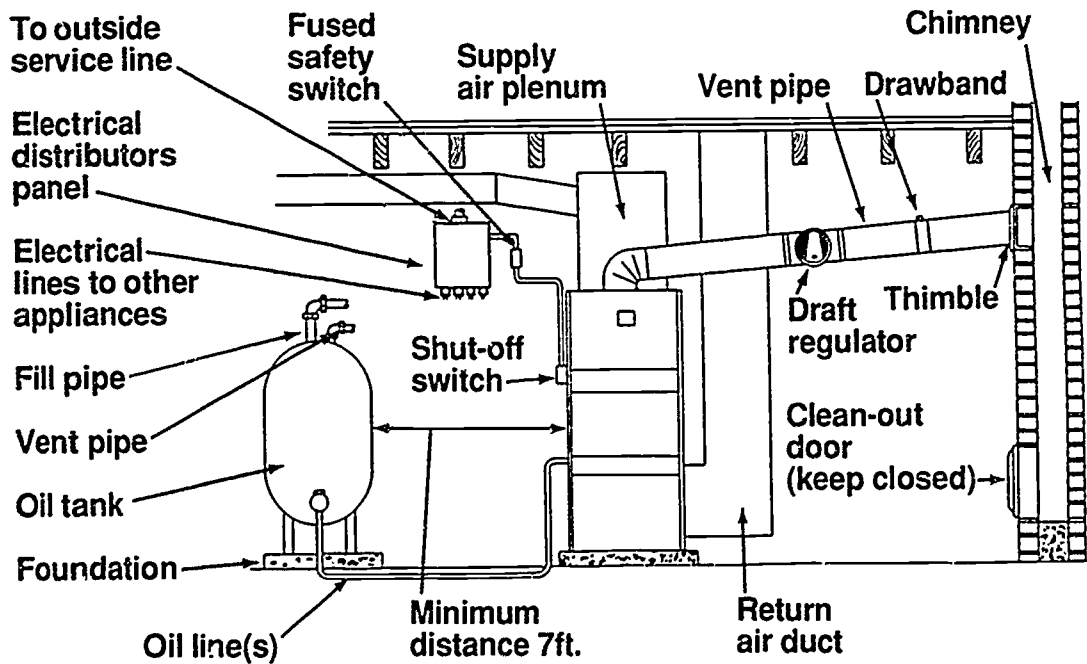

Courtesy Inter-City Products Corporation (USA)

Counterflow Furnace

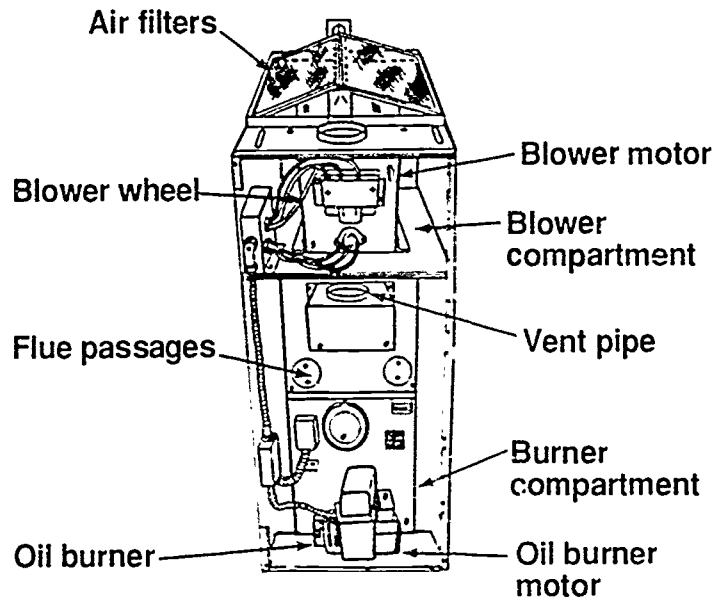

Typical Installation

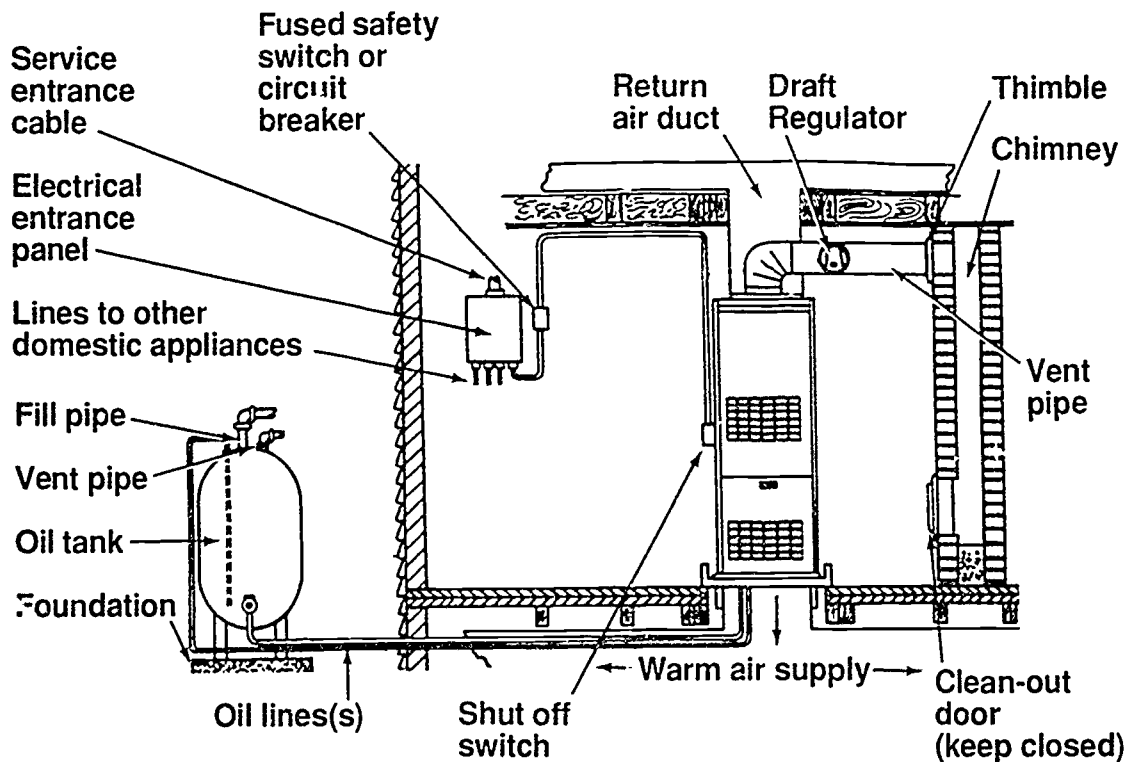

Courtesy Inter-City Products Corporation (USA)

Horizontal Furnace

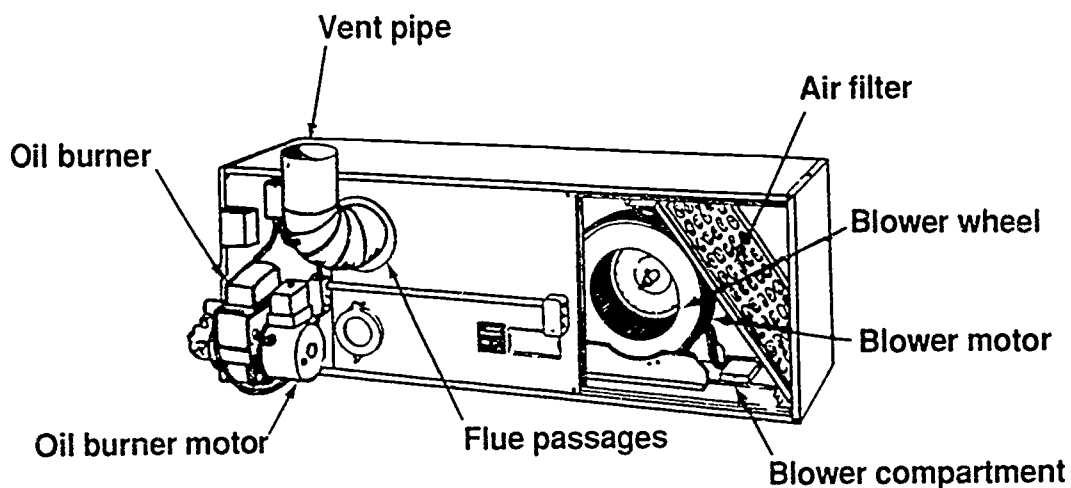

Typical Installation

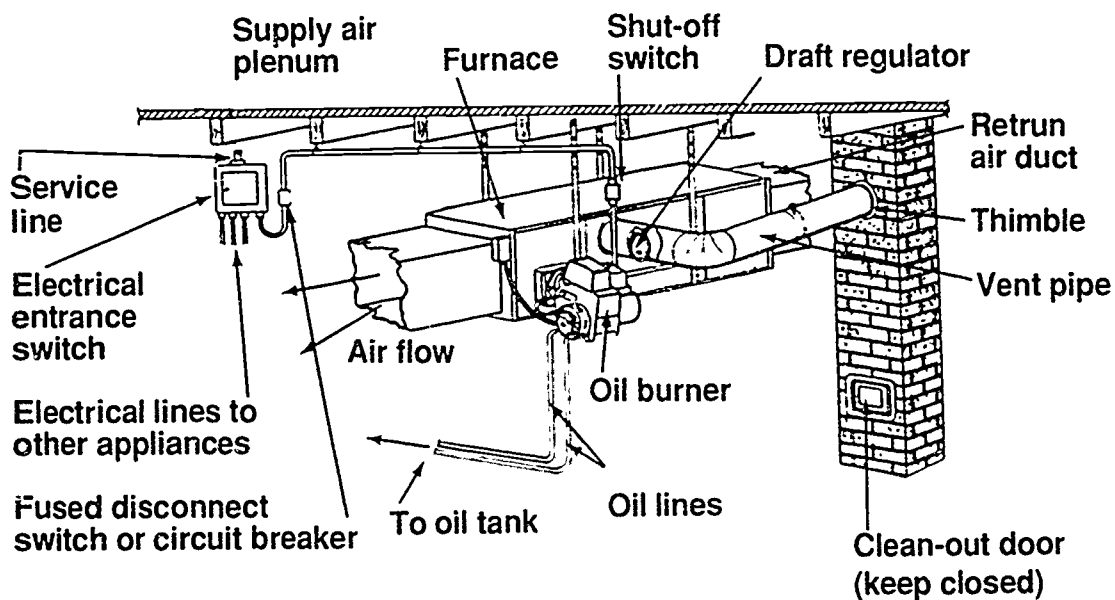

Courtesy Inter-City Products Corporation (USA)

Floor Furnace

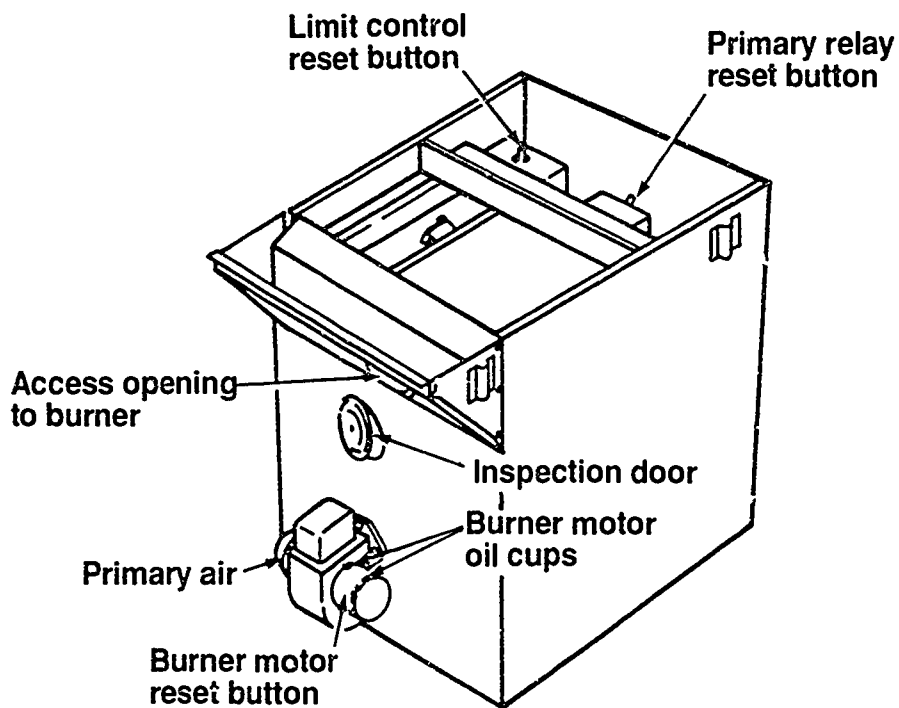

Typical Installation

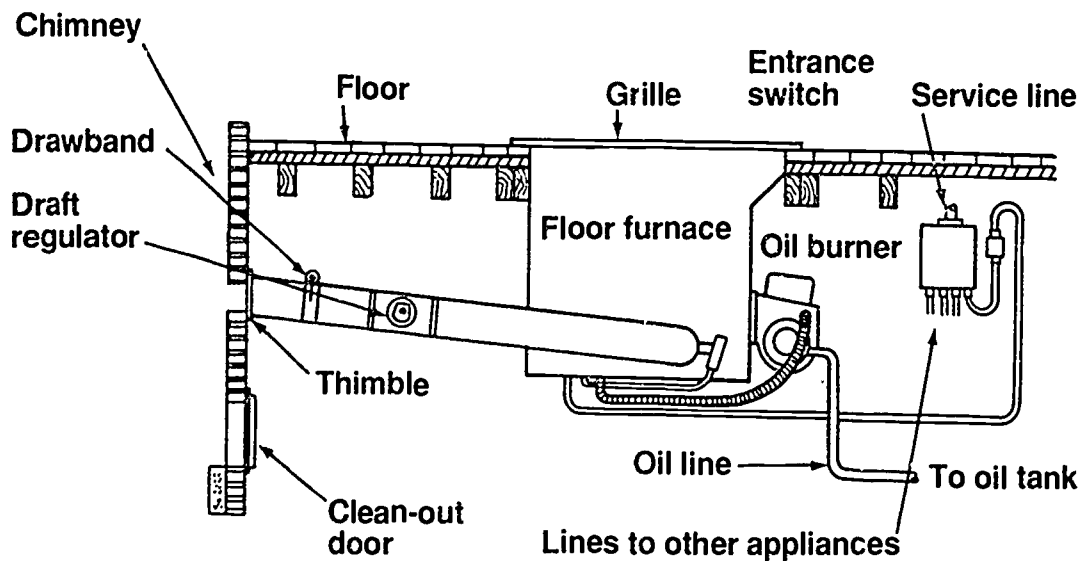

Courtesy Inter-City Products Corporation (USA)

Oil Burner Assembly

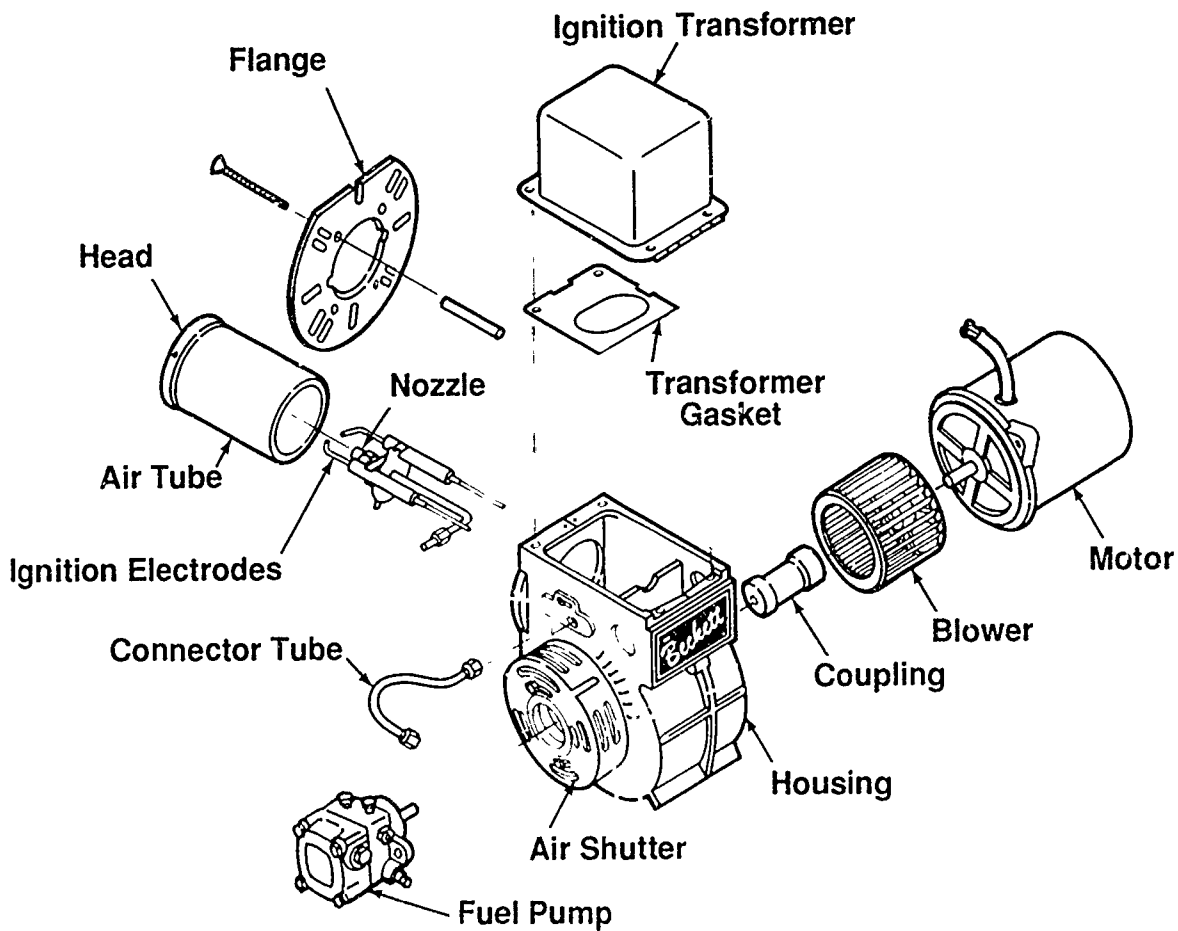

Courtesy R. W. Beckett Corporation

Visual Flame Detectors

Primary Control Functions

1. Respond to heating requirements initiated by the thermostat.
2. Shut down the burner on limit action.
3. Supervise the starting, stopping and running of the burner:
 - Prove the flame.
 - Control the ignition and oil valve.
 - Shut down in the event of system malfunction.

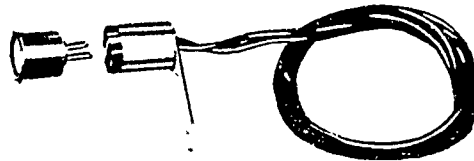

C554 "CAD CELL"

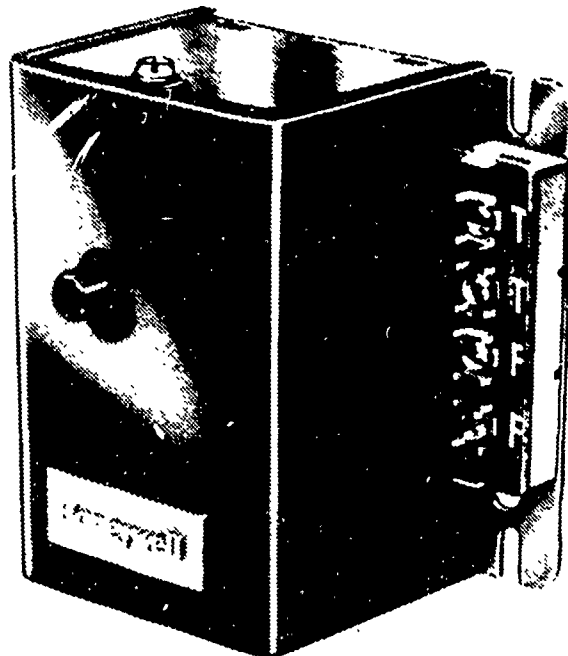

Courtesy Inter-City Products Corporation (USA)

Cad Cell Checkout

Light Cell

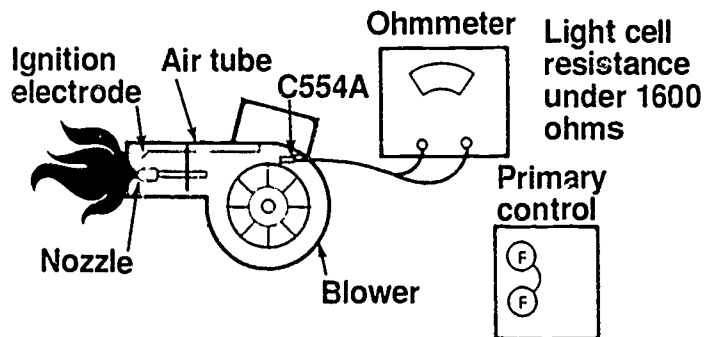

Remove cad cell lead wires from primary control.
 Start burner.
 Jumper (F) (F) terminals to allow burner to run.
 Connect ohmmeter to cad cell lead wires.
 Reading must be less than 1600 ohms.

Dark Cell

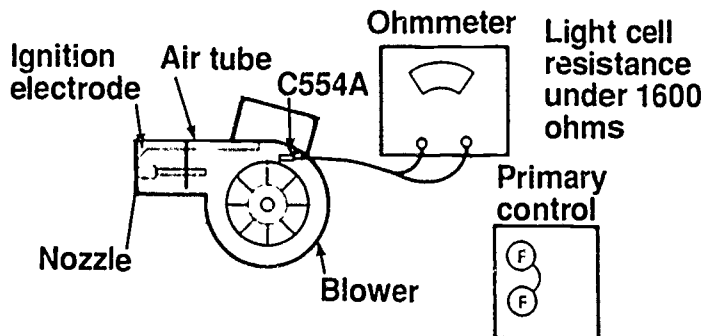

Stop burner.
 Remove the (F) (F) jumper.
 Reading must be 100,000 ohms or more when dark.

Courtesy Inter-City Products Corporation (USA)

Single-Stage Fuel Pump

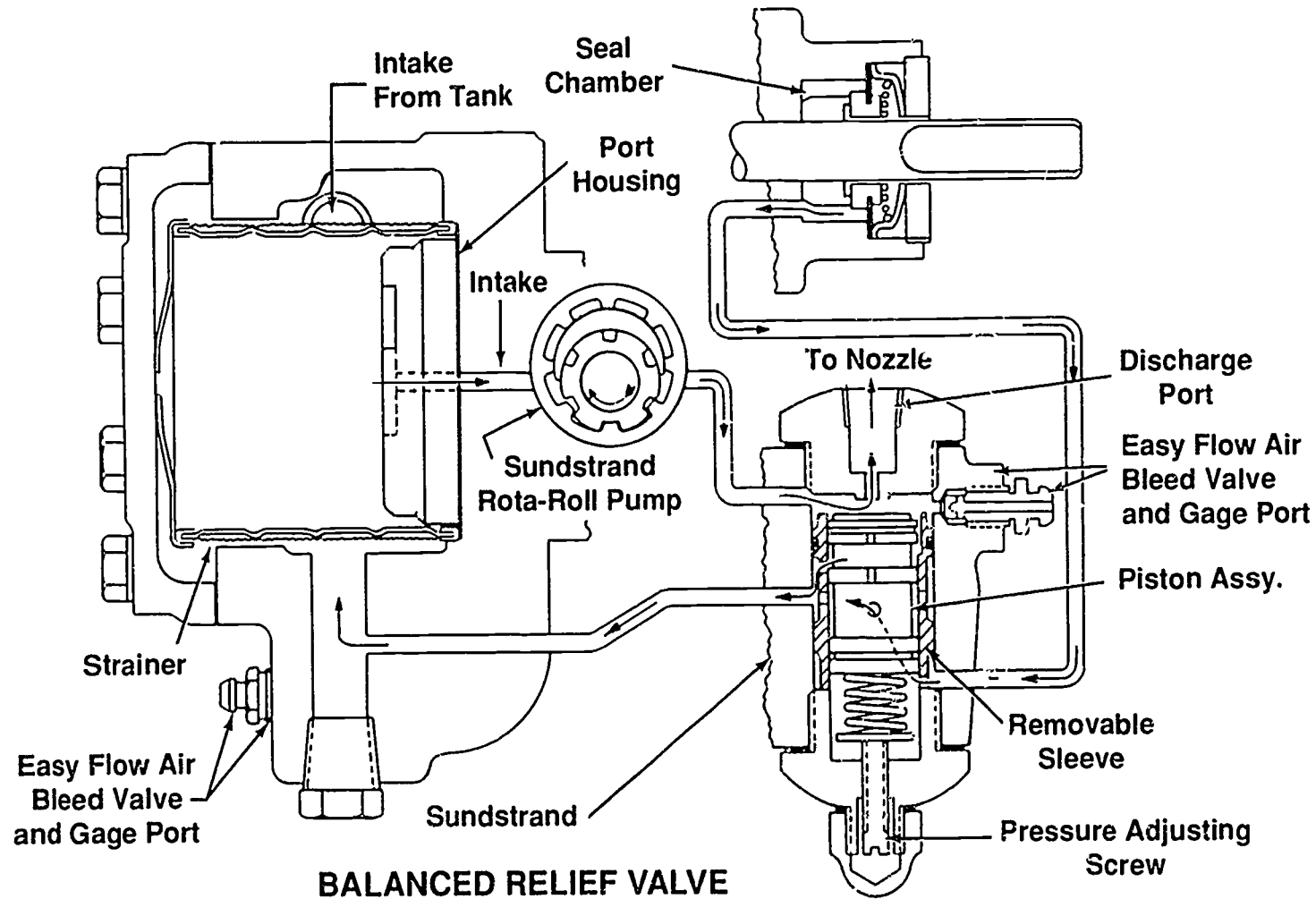

BALANCED RELIEF VALVE

Courtesy Inter-City Products Corporation (USA)

500

501

Two-Stage Fuel Pump

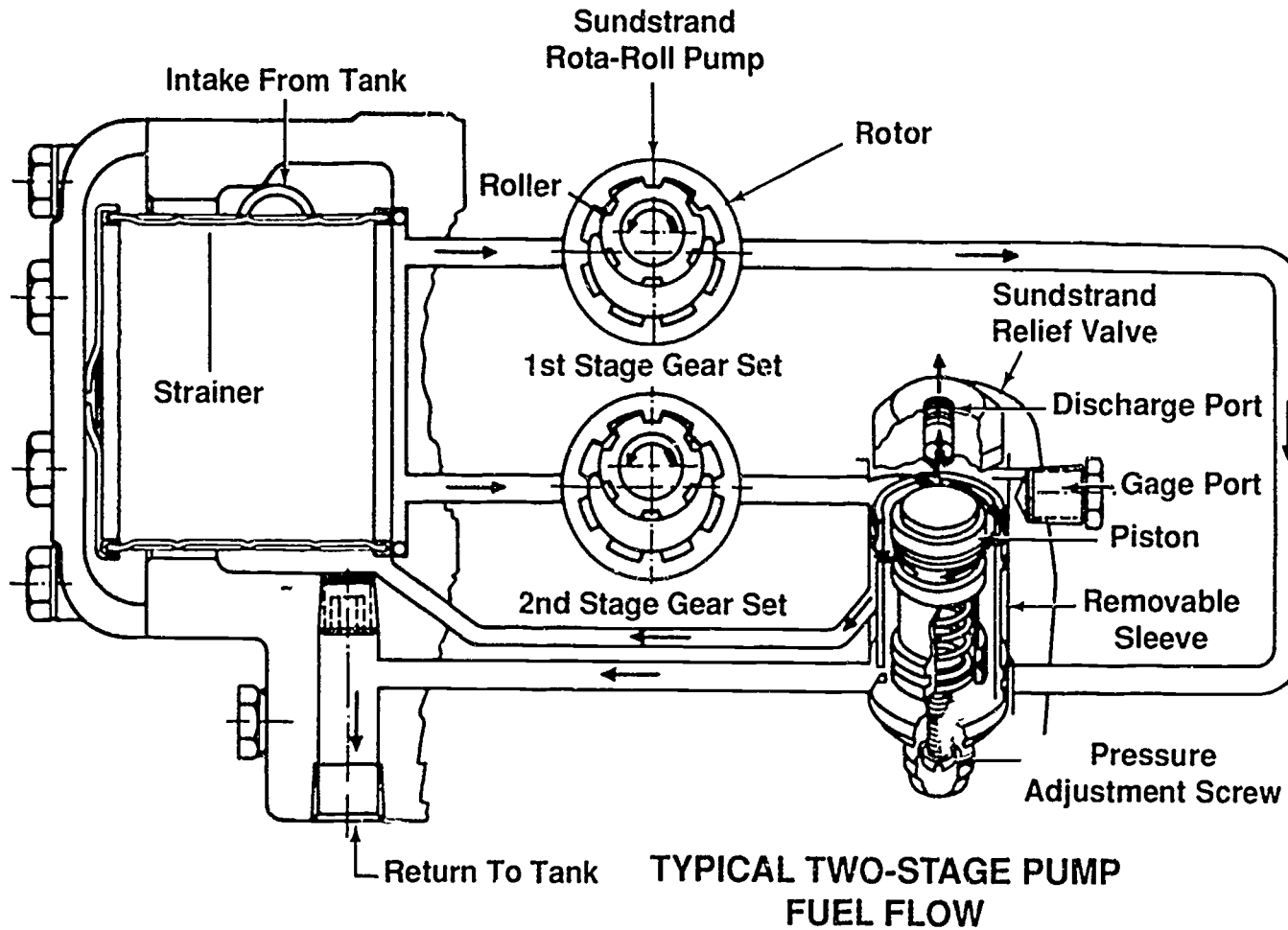

Courtesy Inter-City Products Corporation (USA)

Overfire Draft

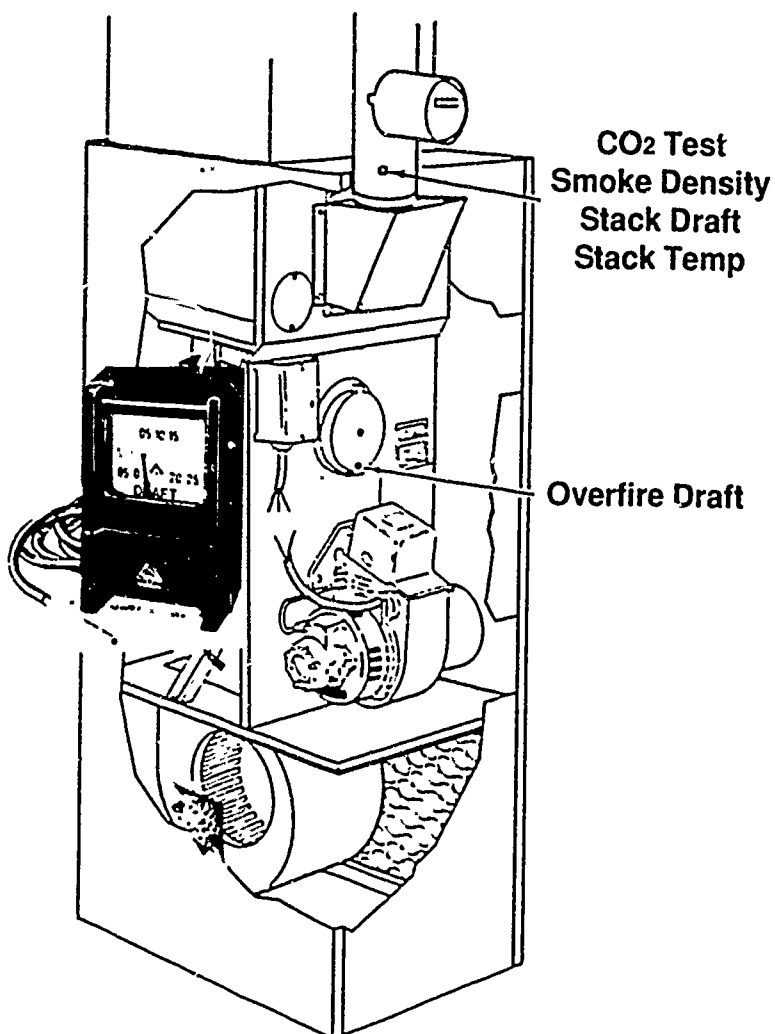

Courtesy Inter-City Products Corporation (USA)

OIL-FIRED FURNACES UNIT XI

HANDOUT #1—OIL STORAGE TANKS

Purpose

The oil storage tanks used with oil-fired furnaces play an important role in system performance. The tanks must be configured to meet local safety codes while providing convenient access for fuel oil delivery. A review of fuel tank requirements will help a technician be more confident about installing and servicing oil-fired furnaces.

Tank location and fuel selection

Tanks are located outside or inside, usually in a basement. Outside tanks generally use Number 1 fuel oil because it will not begin to gel (reach its pour point) until 0°F. Inside tanks used Number 2 fuel oil because its pour point is 20°F. Since most inside tanks are located in a basement or other indoor area, the temperature probably never reaches even close to the 20°F mark. This promotes better efficiency because the Number 2 fuel oil produces 140,000 BTUs per gallon while the Number 1 fuel oil produces 138,000 BTUs per gallon.

Single inside tank installation

Most indoor tanks are obround tanks of welded 14-gauge steel. An indoor tank should be set on a concrete floor, a concrete slab, or supported under its four legs with concrete blocks. To prevent sediment from remaining in the tank, the front part of the tank should be 2 inches lower than the back. The tank should have at least a 1¼ inch vent pipe that runs continuously upward from the tank and terminates outside the building at least 3 feet above ground and a minimum of 3 feet from any door or window. The vent should have a protected weather cap or it should be turned down in an ell shape to protect it from weather. Make sure the vent termination is situated so that it cannot be blocked by snow drafts, leaves, or other debris.

An indoor tank also needs a fill pipe that terminates outside the building so fuel oil can be conveniently delivered. The pipe must be at least 2 inches in size, must terminate at a point at least 5 feet from any building opening that is on the same level, and must be capped at the end so it cannot be obstructed by snow or debris.

An inside tank should also have an oil gauge that constantly measures the amount of fuel in the tank. For convenience, the delivery person should be able to read the gauge from outside. Vent alarms are also a convenience. They fit on the vent pipe and indicate when the tank is full so the delivery person will not overfill the tank and waste fuel oil.

Inside dual tank installations have the same requirements as single tank installations.

HANDOUT #1

Single Inside Tank Installation

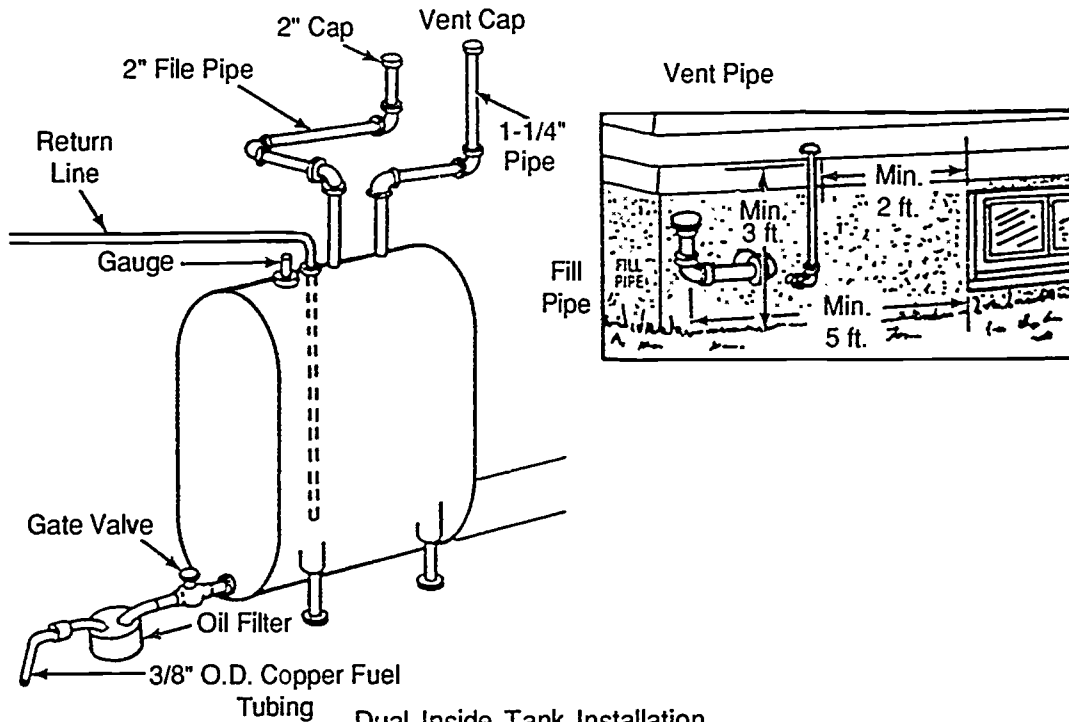

Dual Inside Tank Installation

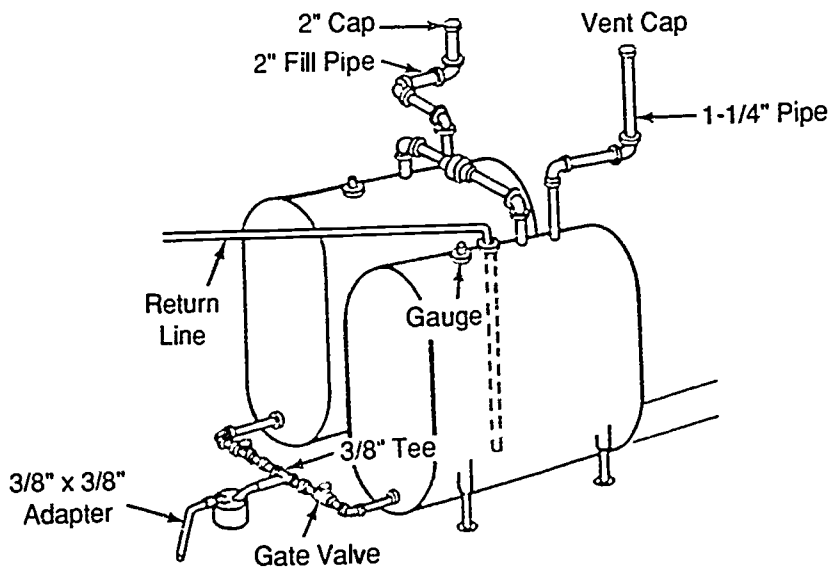

Courtesy Inter-City Products Corporation (USA)

HANDOUT #1

Outside tank installation

Many local codes require that outside tanks be made from steel heavier than 14-gage. Outside tanks may be single or double installations and are usually 275 gallon tanks that are painted with rust-resistant paint (also recommended for indoor tanks). Outside below ground tanks usually hold a thousand gallons of fuel oil and have to be rust-proofed before being buried.

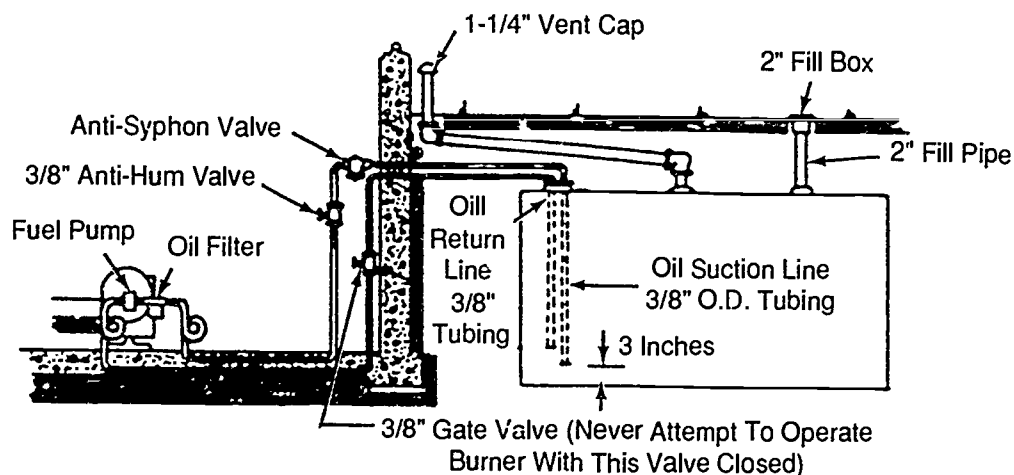
Outside Underground Tank Installation

Courtesy Inter-City Products Corporation (USA)

Other safety requirements for oil storage tanks

A tank of over 60 gallon capacity may not be located above a cellar or basement or above any first-floor room. No tank can be installed closer than 7 feet from the oil burner or any other source of flame. Oil lines need to be protected from damage by placing them in a shallow trench and cementing over them, placing them along the floor/wall angle and cementing over them, or simply covering them with boards. In a two line system, the lines can be run overhead.

When vent and fill pipes are run through a wall to the outside, the holes around them need to be filled with cement to keep out wind and rain. When vent and fill pipes are run through a window opening, the opening should be permanently closed and the line openings sealed with sheet metal or boards.

As with indoor tanks, outdoor tanks should be placed on a 3 to 4 inch concrete slab, and in some cases, local codes requires that an outdoor tank have a dike built around it.

HANDOUT #1

Oil lines

Oil lines may be of standard black iron/pipe using standard pipe fittings of steel or brass. When copper tubing is used for oil lines, it should have a wall/thickness of at least .035 inch and it should be used with brass flare fittings. An oil supply line must not be smaller in diameter than the intake fitting on the burner, and if a return line is used, it must be as large as the supply line and, preferably, one size larger.

The outdoor portions of outdoor lines must be buried deep enough to prevent damage and inside lines should be covered as previously indicated. All joints must be sealed with an approved compound impervious to oil. All lines must be secured in place and the supply line in a gravity feed system should run constantly down from the tank to the burner with no dips or turns. The supply line should also contain a shut-off valve at the tank end, preferably, and an oil filter. A strainer or water and sediment trap should also be at the tank end. In the case of an underground tank, the shut-off valve must be at the burner end.

Conclusion

Oil storage tanks and the oil line configurations play an important part in the performance of an oil-fired furnace. Gravity feed systems have to have a supply line either level with or at a specified distance above the intake of an oil burner. If for any reason the tank has to be below the intake to the burner, a forced-feed two-line system should be used, and the forced-feed system can also solve supply problems with tanks that must be located at a location distant from the furnace. Knowing what to look for with the tank and supply line configuration is a tremendous asset for both installation and maintenance jobs.

OIL-FIRED FURNACES UNIT XI

HANDOUT #2—CHIMNEYS

Purpose

With an oil-fired furnace, a constant draft is needed. Some regulation of draft is accomplished by a draft regulator, but the natural draft in a system depends on having a chimney of the proper height and construction. Knowing when a draft problem is really a chimney problem can add to a technician's troubleshooting skills.

Venting

Venting is the process of moving the products of combustion out of a system through a chimney or vent pipe. Venting works because of natural phenomena: when air is heated, it increases in volume, becomes lighter, and rises through the vent system. As the heated air moves through the vent system, heavier, cooler air is drawn into the combustion chamber to replace it. So venting must accomplish several things: it must move hot combustion gases to the atmosphere, it must protect the structure from fire hazards caused by overheating, and it must prevent the escape of noxious combustion gases into a living space.

The Class A Chimney

A class A chimney can be constructed of masonry, concrete, or metal. However, because masonry materials deteriorate when exposed to combustion products, masonry chimneys used with hydrocarbon fuels are lined with a fired-clay tile liner. Generally speaking, if flue gas or stack temperature is normal and flue pipe and chimney inside areas are large enough, the draft a chimney can pull will depend on its height. Both masonry and composition insulated chimneys can easily pull the drafts listed in the following table:

If the chimney top is
this many feet above
the heating outlet

The chimney should be able
to pull at least this much
draft above the unit, the
stack draft, with the burner
set to rated CO₂ and the draft
regulator almost closed

10 feet _____	.045 inches
15 feet _____	.07 inches
20 feet _____	.09 inches
25 feet _____	.11 inches

Conclusion

A venting problem can mean a chimney problem. Chimney obstructions to watch for include overhanging branches, nests, broken chimney liner, soot accumulation, pipes from other appliances, damaged caps, and chimneys that are just too small. Study Figures 1 and 2 on the following pages to improve your knowledge of chimney structure and chimney problems.

HANDOUT #2

FIGURE 1 For best venting, a chimney should be of minimum height in relation to the burner nozzle size

**FOR BEST HEATING A
MASONRY CHIMNEY
SHOULD . . .**

Be at least the required minimum height (see table).

Be 2 feet or more higher than highest point of roof—or any neighboring roof or object.

Extend 3 feet above highest point where it passes through roof.

Have nothing to restrict the top opening.

Have walls at least 4-inches thick.

Have a smooth, hard, airtight flue (liner) of the correct inside dimensions—and constructed of approved liner material. Flue should extend at least 8 inches below thimble.

Have a sealed in thimble for holding the smoke pipe.

NOTE

Never connect furnace to a flue smaller than furnace outlet collar—always join it to the flue below the smoke pipes of other units.

Have a tightly sealed cleanout door at the very bottom of the flue.

Have a separate flue (or chimney) for other units—except that a water heater burning the same fuel as furnace may join the same flue (above the furnace smoke pipe), if the total area of the two smoke pipes does not exceed the flue area. . . and if chimney is at least 2 feet taller than required minimum height.

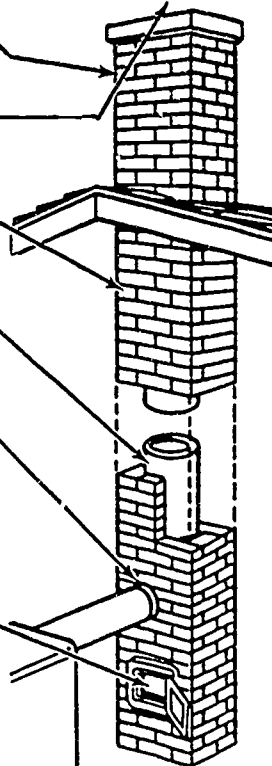

NOTE: All chimney heights are to be measured from top of thimble to top of flue.

±*OIL-FIRED FURNACES

NOZZLE SIZE (Gals. per Hr.)	FLUE HT. (In Feet)	FLUE AREA (In Sq. In.)
0.75 to 1.00	12	38
1.00 to 1.35	12	49
1.35 to 1.75	13	56
1.75 to 2.50	13	77

±The heights and areas shown are the minimum of allowable. Possible, use of 15-ft high chimney. A larger area flue can be used if not more than twice the size listed above.

*If the home is located more than 2,000 ft. above sea level, add 3-ft. to chimney heights for gas-and oil-fired furnaces.

Courtesy Inter-City Products Corporation (USA)

HANDOUT #2

FIGURE 2

COMMON CHIMNEY TROUBLES AND THEIR CORRECTIONS

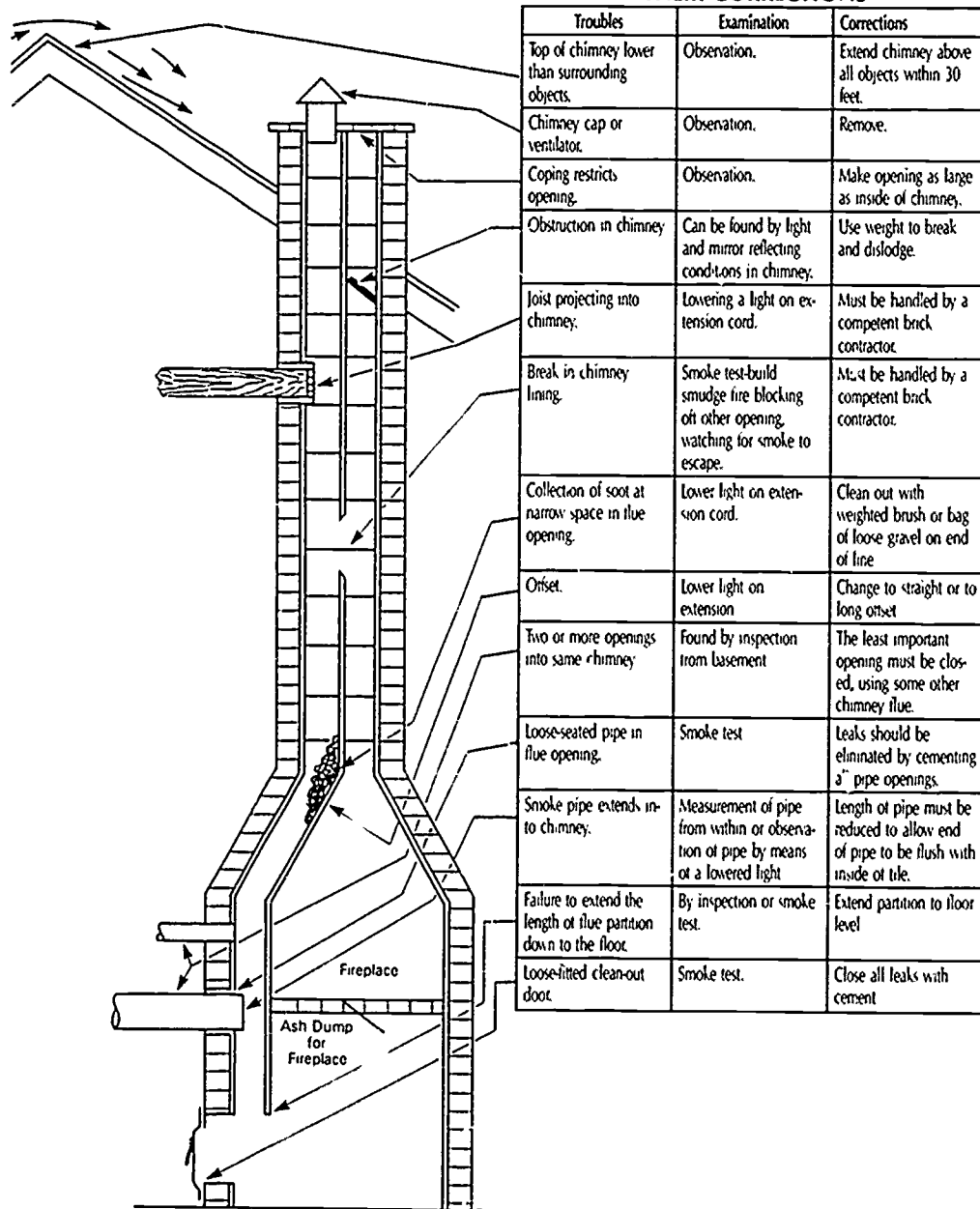

Troubles	Examination	Corrections
Top of chimney lower than surrounding objects.	Observation.	Extend chimney above all objects within 30 feet.
Chimney cap or ventilator.	Observation.	Remove.
Coping restricts opening.	Observation.	Make opening as large as inside of chimney.
Obstruction in chimney.	Can be found by light and mirror reflecting conditions in chimney.	Use weight to break and dislodge.
Joist projecting into chimney.	Lowering a light on extension cord.	Must be handled by a competent brick contractor.
Break in chimney lining.	Smoke test-build smudge fire blocking off other opening, watching for smoke to escape.	Must be handled by a competent brick contractor.
Collection of soot at narrow space in flue opening.	Lower light on extension cord.	Clean out with weighted brush or bag of loose gravel on end of line.
Onset.	Lower light on extension.	Change to straight or to long onset.
Two or more openings into same chimney.	Found by inspection from basement.	The least important opening must be closed, using some other chimney flue.
Loose-seated pipe in flue opening.	Smoke test.	Leaks should be eliminated by cementing a" pipe openings.
Smoke pipe extends into chimney.	Measurement of pipe from within or observation of pipe by means of a lowered light.	Length of pipe must be reduced to allow end of pipe to be flush with inside of tile.
Failure to extend the length of flue partition down to the floor.	By inspection or smoke test.	Extend partition to floor level.
Loose-fitted clean-out door.	Smoke test.	Close all leaks with cement.

Courtesy Inter-City Products Corporation (USA)

OIL-FIRED FURNACES UNIT XI

JOB SHEET #1—INSTALL AN OIL-FIRED FURNACE

A. Tools and equipment

1. Service technician's tool pouch or box
2. Aviation snips
3. Electric drill and bits
4. Screwdrivers
5. Sheet metal screws as required
6. Level
7. Duct tape
8. Electric reciprocating saw and blades
9. Safety glasses
10. Furnace selected by instructor
11. Wall thermostat

B. Procedure

1. Inspect work area for safety.
2. Remove crating.
3. Read manufacturers installation instructions.
4. Put on safety glasses.
5. Set furnace in place making sure it is in a level position.
6. Adapt and fasten supply ducts to the furnace cabinet.
7. Adapt and fasten return ducts to the furnace cabinet.
8. Connect fuel line, making sure all connections are tight

(CAUTION: Never use teflon tape on fuel line threaded connections as it will dissolve and end up in the pump. It could possibly prevent the piston from closing, allowing oil to drain from the storage tank creating a fire hazard.)

9. Connect the furnace to an approved flue with a vent pipe approved for an oil furnace.

JOB SHEET #1

10. Install the draft regulator.

(CAUTION: Make sure all required clearances from combustible materials are maintained.)

11. Connect thermostat control wiring to proper terminals in the furnace.

12. Mount the wall thermostat, making sure it is level.

13. Connect control wiring to proper terminals in the thermostat.

14. Adjust heat anticipator to setting called for by furnace manufacturer

(NOTE: If setting is not in the specifications it will be necessary to measure amp draw on the heating circuit and set anticipator accordingly.)

15. Connect power supply to proper terminals in the furnace.

16. Provide openings for adequate combustion and ventilation air.

17. Check the chimney outside the structure to make sure it is not obstructed by tree limbs, other structures, or anything that would impair its proper performance.

18. Check furnace again to make sure it is still level.

(NOTE: This assures that any oil accumulation will drain into the combustion chamber reducing a fire hazard condition.)

- Have your instructor check your installation.

19. Clean the work area and return tools to proper storage.

**OIL-FIRED FURNACES
UNIT XI****JOB SHEET #2—PERFORM A STACK TEMPERATURE
TEST ON AN OIL-FIRED FURNACE****A. Tools and equipment**

1. Service technician's tool pouch or box
2. Stack thermometer (1000°F range)
3. Flashlight and inspection mirror
4. Oil-fired furnace as selected by instructor
5. Hand drill and 1/4" bit
6. Pencil and paper
7. Service thermometer
8. Safety glasses

B. Procedure

1. Inspect the work area for safe working conditions and put on safety glasses.
2. Drill a 1/4" hole in the flue pipe about 12 inches from the breeching and at least 6 inches ahead of the draft regulator.
3. Turn the oil burner on and allow at least 5 minutes of operation before starting the test.
4. Insert the stack thermometer into the drilled hole in such a way that the thermometer reaches into the center third of the flue pipe diameter.
5. Read and record the temperature after the thermometer stabilizes:
_____.
6. Use the service thermometer to take the combustion air temperature at a point about a foot away from the furnace and record it here:
_____.
7. Subtract the combustion air reading from the stack temperature reading to get the net stack temperature, and record it here: _____.
8. Turn the furnace off.

JOB SHEET #2

9. Evaluate the flue stack temperature reading according to the following general guidelines:
1. If you are working with a conversion-type furnace, the reading should probably be 600°F to 700°F.
 2. If your working with a package unit, the reading should probably be 400°F to 500°F.
 3. If you have manufacturer's specifications available, always refer to them.
 4. If you have an excessive stack temperature reading, it means the furnace has a problem that will require further troubleshooting and evaluation.

(NOTE: At this point you would normally use a sheet metal screw to plug the hole in the flue, but for now, leave the hole open for use in the next job sheet.)
10. Discuss your findings with your instructor.
- Have your instructor evaluate your work.
11. Clean tools and equipment and return them to proper storage.

515

**OIL-FIRED FURNACES
UNIT XI****JOB SHEET #3—PERFORM A CO₂ TEST AND DETERMINE THE
COMBUSTION EFFICIENCY OF AN OIL-FIRED FURNACE****A. Tools and equipment**

1. Service technician's tool pouch or box
2. CO₂ tester
3. Combustion efficiency slide rule
4. Oil-fired furnace as selected by instructor
5. Pencil and paper
6. Safety glasses

B. Procedure

1. Inspect the work area for safe working conditions and put on safety glasses.
2. Turn the oil burner on and allow at least 5 minutes of operation before starting the CO₂ test.
3. Place the sampling tube that comes out of the bottom of the squeeze bulb into the hole previously drilled in the flue.
4. Place the hose that comes out of the top of the squeeze bulb over the top of the indicator so that it is on the plunger valve and hold it down tight with a finger.
5. Count carefully as you squeeze the aspirator bulb 18 times and hold it closed on the 18th squeeze.
6. Release the depressed plunger valve after the 18th squeeze of the bulb and then release the bulb.
7. Turn the indicator over twice so that the test fluid runs back and forth in order to absorb the flue gas sample.
8. Hold the indicator in an upright, level position and read the test liquid on the scale that is calibrated directly in percent CO₂.

(CAUTION: The absorbent solution in the CO₂ indicator is poison and should be handled with care. If you get some on your skin, flood it with water and then wash with vinegar. If you get any in your eyes, wash with a 5% boric acid solution. If taken internally, give vinegar or lemon juice copiously.)

JOB SHEET #3

9. Move the horizontal slide on the efficiency rule until the measured stack temperature appears in the window marked "stack temperature."

(NOTE: Use your stack temperature reading from Job Sheet #2.)

10. Move the vertical slide until the black arrow points to the measured percent of CO₂.
11. Note the figures in the cut-out of the arrow on the vertical scale; this is the combustion efficiency expressed in percentage.
12. Record the combustion efficiency here: _____%.
13. Refer to Job Sheet #2 for your net stack temperature, and evaluate your CO₂ percentage according to the following:

- a. A CO₂ reading of 10% is considered satisfactory.
- b. If the net stack temperature is less than 400°F, a CO₂ percentage of 8% may be tolerated.
- c. If the net stack temperature is over 500°F, a CO₂ percentage of 9% should be the target.
- d. If the CO₂ percentage is low, look for problems with high draft, excess combustion air, defective or incorrect firebox, air leakage, poor oil atomization, worn, plugged, or incorrect nozzle, incorrect oil pressure, incorrect air handling parts, or erratic draft regulator operation.

(NOTE: At this point you would normally use a sheet metal screw to plug the hole in the flue, but for now, leave the hole open for use in the next job sheet.)

14. Discuss your CO₂ testing with your instructor.
- Have your instructor evaluate your work.
15. Clean tools and equipment and return to proper storage.

517

OIL-FIRED FURNACES
UNIT XI

JOB SHEET #4—PERFORM A SMOKE TEST
ON AN OIL-FIRED FURNACE

A. Tools and equipment

1. Service technician's tool pouch or box
2. Smoke tester
3. Oil-fired furnace as selected by instructor
4. Pencil and paper
5. Safety glasses

B. Procedure

1. Inspect the work area for safe working conditions and put on safety glasses.
2. Turn the burner on and allow 5 minutes of operation before starting the test.
3. Insert the free end of the tester's sampling tube into the hole in the flue.
4. Place filter paper into the "holding slot" on the tester.
5. Pull the smoke tester handle through 10 full pump strokes, but pause several seconds between pump strokes.
6. Remove the filter from the holding slot.
7. Compare the smoke spot on the filter with the smoke scale numbers.
8. Match your sample with the closest color on the smoke scale.

JOB SHEET #4

9. Evaluate your soot test paper according to the following Bacharach smoke number:

EFFECT OF SMOKE ON BURNER PERFORMANCE		
BACHARACH SMOKE SCALE NO	RATING	SOOTING PRODUCED
1	EXCELLENT	EXTREMELY LIGHT IF AT ALL
2	GOOD	SLIGHT SOOTING WHICH WILL NOT INCREASE STACK TEMPERATURE APPRECIABLY
3	FAIR	MAY BE SOME SOOTING BUT WILL RARELY REQUIRE CLEANING MORE THAN ONCE A YEAR
4	POOR	BORDERLINE CONDITION SOME UNITS WILL REQUIRE CLEANING MORE THAN ONCE A YEAR
5	VARY POOR	SOOT RAPIDLY AND HEAVILY

Courtesy Bacharach, Inc.

10. Check for a rating of less than "fair" and look for problems such as improper fan delivery, insufficient draft, improper oil pump operation, defective or incorrect nozzle, boiler or furnace has excessive air leaks, improper fuel-air ratio, defective firebox, improperly adjusted draft regulator, or improper air handling parts on the burner.

(NOTE: At this time you would normally use a sheet metal screw to close the hole in the flue, but unless your instructor indicates otherwise, leave the hole open for the next job sheet.)

11. Discuss your findings with your instructor.
- Have your instructor evaluate your work.
12. Clean area and equipment and return equipment to storage.

**OIL-FIRED FURNACES
UNIT XI****JOB SHEET #5—PERFORM AN "OVERFIRE DRAFT" AND A
"FLUE DRAFT" TEST ON AN OIL-FIRED FURNACE****A. Tools and equipment**

1. Service technician's tool pouch or box
2. Draft gauge
3. Oil-fired furnace as selected by instructor
4. Hand drill and 1/4" bit
5. Pencil and paper
6. Safety glasses

B. Procedure

1. Inspect the work area for safe working conditions and put on safety glasses.
2. Drill a 1/4 inch hole in the fire door or remove one of the bolts holding the fire door lining to the door.
3. Turn the burner on and allow at least 5 minutes of operation before continuing with the tests.
4. Make sure the draft gauge is level, then adjust it to zero.
5. Insert the draft tube into the hole in the fire door.
6. Read and record the "overfire draft" findings in inches of water column:

7. Check with your instructor if your reading is less than .02 inches water column because .02 of an inch is the minimum considered sufficient to maintain proper combustion.
8. Remove the draft tube from the fire door.
9. Insert the draft tube into the hole in the flue pipe.
10. Read the draft gauge and record it in inches of water column:

11. Check with your instructor if your reading is below .04 inches of water column because most residential furnaces with firing rates not above 1.5 gph need a flue pipe draft between .04 and .06 inches to maintain a .02 inch draft in the fire box.

JOB SHEET #5

12. Turn the burner off.
13. Discuss your findings with your instructor.
- Have your instructor evaluate your work.
14. Use sheet metal screws to stop the holes in the flue and fire door or replace the bolt that holds the fire door lining.
15. Clean tools and equipment and return to proper storage.

OIL-FIRED FURNACES UNIT XI

JOB SHEET #6—PERFORM FUEL PUMP SERVICE ON AN OIL-FIRED FURNACE

A. Tools and equipment

1. Service technician's tool pouch or box
2. Oil-fired furnace as selected by instructor
3. 0-300 PSIG gauge
4. Container to catch fuel oil
5. Pan to hold kerosine for cleaning
6. Utility brush
7. Clean shop cloth
8. Replacement fuel filter
9. Plastic tubing
10. Kerosine for cleaning
11. Safety glasses

B. Procedure

1. Inspect the work area for safe working conditions and put on safety glasses.
2. Turn the fuel supply valve off at the fuel tank.
3. Remove and replace the in-line fuel filter cartridge.
4. Remove the strainer end cap assembly on the oil pump. (Figure 1)

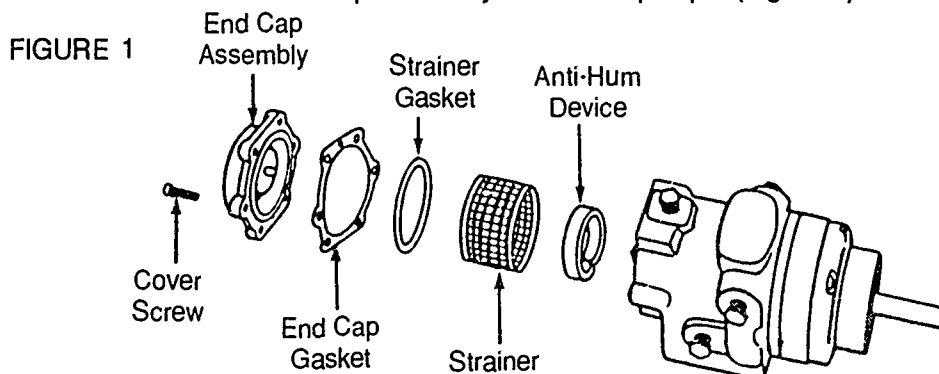

Courtesy Inter-City Products Corporation (USA)

JOB SHEET #6

5. Put enough kerosine in a pan to clean the strainer.
 6. Remove the strainer and clean it.
 7. Replace strainer, put end cap assembly back in place and tighten it.
 8. Turn the fuel valve on.
 9. Install a 0-300 PSIG gauge in the gauge port of the fuel pump.
 10. Turn the furnace on and make sure the burner is operating.
 11. Adjust the pressure adjusting screw for 100 PSI.
 12. Turn the furnace off and remove the gauge.
 13. Check the regulator cut-off pressure by installing the 0-300 PSIG gauge in the nozzle discharge port.

(NOTE: With the above step, you may have to remove the nozzle feed line in order to properly set the gauge.)
 14. Turn the furnace on again, make sure the burner is operating, and observe and record the gauge pressure: _____.
 15. Turn the furnace off and watch the drop on the pressure gauge, and if the drop exceeds 20 PSI, replace the fuel pump.
 16. Turn the furnace off and remove the pressure gauge.
 17. Place a container below the bleed port and use tubing to funnel oil into the container.
 18. Start the furnace and slowly open the bleed port.
 19. Watch for oil with air bubbles to begin flowing from the bleed port, and when the bubbles disappear and there is a constant flow of oil, close the bleed port.
 20. Turn the furnace off.
 21. Clean up any spilled oil.
 22. Clean tools and equipment and return them to storage.

(NOTE: Dispose of fuel oil as specified by safety requirements.)
- Have your instructor check your work.

**OIL-FIRED FURNACES
UNIT XI**

**JOB SHEET #7—PERFORM BURNER MAINTENANCE ON
AN OIL-FIRED FURNACE**

A. Tools and equipment

1. Service technician's tool pouch or box
2. Oil-fired furnace as selected by instructor
3. Lubricants to specifications
4. Clean shop cloth
5. Replacement nozzle (if required)
6. Replacement electrodes (if required)
7. Shop vacuum cleaner
8. Replacement air handling filters
9. Safety glasses

B. Procedure

1. Inspect work area for safety working conditions and put on safety glasses.
2. Check and clean or check and replace the nozzle as required.
3. Check the nozzle spray angle to make sure it agrees with specifications.
4. Make sure nozzle is tight and properly centered.
5. Check electrode settings and verify them with manufacturer's specifications.
(NOTE: Depending on furnace type, the electrode gap may range from 1/8 inch to 3/16 inch.)
6. Check electrode ends for distance from the nozzle.
(NOTE: Depending on furnace type, the distance could range from 1/2 inch to 5/26 depending on the degree angle of the nozzle.)
7. Check the porcelain insulators for cracks, and replace as needed.
8. Oil the oil burner motor to specifications.
9. Clean the burner blower with a shop vacuum.
10. Oil the furnace air handling blower motor to specifications.

JOB SHEET #7

11. Clean air handling blower wheel as required.
12. Replace air handling filters.
- Have your instructor check your work.
13. Clean area and return tools to proper storage.

525

**OIL-FIRED FURNACES
UNIT XI**

**PRACTICAL TEST #1
JOB SHEET #1 — INSTALL AN OIL-FIRED FURNACE**

Student's name _____ Date _____

Evaluator's name _____ Attempt no. _____

Student instructions: When you are ready to perform this task, ask your instructor to observe the procedure and complete this form. All items listed under "Process Evaluation" must receive a "Yes" for you to receive an overall performance evaluation.

PROCESS EVALUATION

(EVALUATOR NOTE: Place a check mark in the "Yes" or "No" blanks to designate whether or not the student has satisfactorily achieved each step in this procedure. If the student is unable to achieve this competency, have the student review the materials and try again.)

The student:	YES	NO
1. Set and leveled furnace.	<input type="checkbox"/>	<input type="checkbox"/>
2. Connected supply ducts properly.	<input type="checkbox"/>	<input type="checkbox"/>
3. Connected return ducts properly.	<input type="checkbox"/>	<input type="checkbox"/>
4. Connected fuel lines properly.	<input type="checkbox"/>	<input type="checkbox"/>
5. Connected furnace to flue properly.	<input type="checkbox"/>	<input type="checkbox"/>
6. Installed draft regulator to specifications.	<input type="checkbox"/>	<input type="checkbox"/>
7. Mounted and connected thermostat.	<input type="checkbox"/>	<input type="checkbox"/>
8. Set heat anticipator.	<input type="checkbox"/>	<input type="checkbox"/>
9. Connected power supply.	<input type="checkbox"/>	<input type="checkbox"/>
10. Checked for proper combustion and ventilation air.	<input type="checkbox"/>	<input type="checkbox"/>

Evaluator's comments: _____

JOB SHEET #1 PRACTICAL TEST

PRODUCT EVALUATION

(EVALUATOR NOTE: Rate the student on the following criteria by circling the appropriate numbers. Each item must be rated at least a "3" for mastery to be demonstrated. (See performance evaluation key below.) If the student is unable to demonstrate mastery, student materials should be reviewed and another test procedure must be submitted for evaluation.)

Criteria:

Uncrating and installation	4	3	2	1
Supply and return duct applications	4	3	2	1
Fuel line connections	4	3	2	1
Draft regulator adjustment	4	3	2	1
Electrical components	4	3	2	1

EVALUATOR'S COMMENTS: _____

PERFORMANCE EVALUATION KEY

- 4 — **Skilled** — Can perform job with no additional training.
- 3 — **Moderately skilled** — Has performed job during training program; limited additional training may be required.
- 2 — **Limited skill** — Has performed job during training program; additional training is required to develop skill.
- 1 — **Unskilled** — Is familiar with process, but is unable to perform job.

(EVALUATOR NOTE: If an average score is needed to coincide with a competency profile, total the designated points in "Product Evaluation" and divide by the total number of criteria.)

527

**OIL-FIRED FURNACES
UNIT XI**

**PRACTICAL TEST #2
JOB SHEET #2 — PERFORM A STACK TEMPERATURE TEST
ON AN OIL-FIRED FURNACE**

Student's name _____ Date _____

Evaluator's name _____ Attempt no. _____

Student instructions: When you are ready to perform this task, ask your instructor to observe the procedure and complete this form. All items listed under "Process Evaluation" must receive a "Yes" for you to receive an overall performance evaluation.

PROCESS EVALUATION

(EVALUATOR NOTE: Place a check mark in the "Yes" or "No" blanks to designate whether or not the student has satisfactorily achieved each step in this procedure. If the student is unable to achieve this competency, have the student review the materials and try again.)

The student:	YES	NO
1. Drilled proper flue hole.	<input type="checkbox"/>	<input type="checkbox"/>
2. Made proper stack temperature measurement.	<input type="checkbox"/>	<input type="checkbox"/>
3. Made proper combustion air temperature measurement.	<input type="checkbox"/>	<input type="checkbox"/>
4. Calculated net stack temperature properly.	<input type="checkbox"/>	<input type="checkbox"/>
5. Evaluated readings properly.	<input type="checkbox"/>	<input type="checkbox"/>

Evaluator's comments: _____

JOB SHEET #2 PRACTICAL TEST

PRODUCT EVALUATION

(EVALUATOR NOTE: Rate the student on the following criteria by circling the appropriate numbers. Each item must be rated at least a "3" for mastery to be demonstrated. (See performance evaluation key below.) If the student is unable to demonstrate mastery, student materials should be reviewed and another test procedure must be submitted for evaluation.)

Criteria: _____

Stack temperature reading	4	3	2	1
Combustion air temperature reading	4	3	2	1
Net stack temperature calculation	4	3	2	1
Safe working procedures	4	3	2	1

EVALUATOR'S COMMENTS: _____

PERFORMANCE EVALUATION KEY

- 4 — **Skilled** — Can perform job with no additional training.
- 3 — **Moderately skilled** — Has performed job during training program; limited additional training may be required.
- 2 — **Limited skill** — Has performed job during training program; additional training is required to develop skill.
- 1 — **Unskilled** — Is familiar with process, but is unable to perform job.

(EVALUATOR NOTE: If an average score is needed to coincide with a competency profile, total the designated points in "Product Evaluation" and divide by the total number of criteria.)

**OIL-FIRED FURNACES
UNIT XI**

**PRACTICAL TEST #3
JOB SHEET #3 — PERFORM A CO₂ TEST AND DETERMINE THE
COMBUSTION EFFICIENCY OF AN OIL-FIRED FURNACE**

Student's name _____ Date _____

Evaluator's name _____ Attempt no. _____

Student instructions: When you are ready to perform this task, ask your instructor to observe the procedure and complete this form. All items listed under "Process Evaluation" must receive a "Yes" for you to receive an overall performance evaluation.

PROCESS EVALUATION

(EVALUATOR NOTE: Place a check mark in the "Yes" or "No" blanks to designate whether or not the student has satisfactorily achieved each step in this procedure. If the student is unable to achieve this competency, have the student review the materials and try again.)

The student:	YES	NO
1. Placed sampling tube into flue hole properly.	<input type="checkbox"/>	<input type="checkbox"/>
2. Placed hose on plunger valve properly.	<input type="checkbox"/>	<input type="checkbox"/>
3. Operated aspirator squeeze bulb 18 times.	<input type="checkbox"/>	<input type="checkbox"/>
4. Released plunger valve and bulb in proper order.	<input type="checkbox"/>	<input type="checkbox"/>
5. Turned indicator so fluid would absorb flue gas sample.	<input type="checkbox"/>	<input type="checkbox"/>
6. Made correct percent CO ₂ reading.	<input type="checkbox"/>	<input type="checkbox"/>
7. Used slide scale to determine combustion efficiency.	<input type="checkbox"/>	<input type="checkbox"/>
8. Evaluated findings properly.	<input type="checkbox"/>	<input type="checkbox"/>

Evaluator's comments: _____

JOB SHEET #3 PRACTICAL TEST

PRODUCT EVALUATION

(EVALUATOR NOTE: Rate the student on the following criteria by circling the appropriate numbers. Each item must be rated at least a "3" for mastery to be demonstrated. (See performance evaluation key below.) If the student is unable to demonstrate mastery, student materials should be reviewed and another test procedure must be submitted for evaluation.)

Criteria:

Set up of sampling equipment	4	3	2	1
Proper use of aspirator bulb	4	3	2	1
Proper indicator use	4	3	2	1
Combustion efficiency calculation		3	2	1

EVALUATOR'S COMMENTS: _____

PERFORMANCE EVALUATION KEY

- 4 — **Skilled** — Can perform job with no additional training.
- 3 — **Moderately skilled** — Has performed job during training program; limited additional training may be required.
- 2 — **Limited skill** — Has performed job during training program; additional training is required to develop skill.
- 1 — **Unskilled** — Is familiar with process, but is unable to perform job.

(EVALUATOR NOTE: If an average score is needed to coincide with a competency profile, total the designated points in "Product Evaluation" and divide by the total number of criteria.)

**OIL-FIRED FURNACES
UNIT XI**

**PRACTICAL TEST #4
JOB SHEET #4 — PERFORM A SMOKE TEST
ON AN OIL-FIRED FURNACE**

Student's name _____ Date _____

Evaluator's name _____ Attempt no. _____

Student instructions: When you are ready to perform this task, ask your instructor to observe the procedure and complete this form. All items listed under "Process Evaluation" must receive a "Yes" for you to receive an overall performance evaluation.

PROCESS EVALUATION

(EVALUATOR NOTE: Place a check mark in the "Yes" or "No" blanks to designate whether or not the student has satisfactorily achieved each step in this procedure. If the student is unable to achieve this competency, have the student review the materials and try again.)

The student:	YES	NO
1. Placed sampling tube into flue hole.	<input type="checkbox"/>	<input type="checkbox"/>
2. Placed filter properly into tester.	<input type="checkbox"/>	<input type="checkbox"/>
3. Pulled smoke tester handle through 10 full pumps.	<input type="checkbox"/>	<input type="checkbox"/>
4. Compared smoke spot on filter with smoke scale standards.	<input type="checkbox"/>	<input type="checkbox"/>
5. Evaluated smoke test according to smoke scale numbers.	<input type="checkbox"/>	<input type="checkbox"/>
6. Evaluated test results according to system performance.	<input type="checkbox"/>	<input type="checkbox"/>

Evaluator's comments: _____

JOB SHEET #4 PRACTICAL TEST

PRODUCT EVALUATION

(EVALUATOR NOTE: Rate the student on the following criteria by circling the appropriate numbers. Each item must be rated at least a "3" for mastery to be demonstrated. (See performance evaluation key below.) If the student is unable to demonstrate mastery, student materials should be reviewed and another test procedure must be submitted for evaluation.)

Criteria: _____

Smoke tester preparation	4	3	2	1
--------------------------	---	---	---	---

Sample collection	4	3	2	1
-------------------	---	---	---	---

Smoke spot evaluation	4	3	2	1
-----------------------	---	---	---	---

System evaluation	4	3	2	1
-------------------	---	---	---	---

EVALUATOR'S COMMENTS: _____

PERFORMANCE EVALUATION KEY

- 4 — **Skilled** — Can perform job with no additional training.
- 3 — **Moderately skilled** — Has performed job during training program; limited additional training may be required.
- 2 — **Limited skill** — Has performed job during training program; additional training is required to develop skill.
- 1 — **Unskilled** — Is familiar with process, but is unable to perform job.

(EVALUATOR NOTE: If an average score is needed to coincide with a competency profile, total the designated points in "Product Evaluation" and divide by the total number of criteria.)

**OIL-FIRED FURNACES
UNIT XI**

**PRACTICAL TEST #5
JOB SHEET #5 — PERFORM AN "OVERFIRE DRAFT" AND A
"FLUE DRAFT" TEST ON AN OIL-FIRED FURNACE**

Student's name _____ Date _____

Evaluator's name _____ Attempt no. _____

Student instructions: When you are ready to perform this task, ask your instructor to observe the procedure and complete this form. All items listed under "Process Evaluation" must receive a "Yes" for you to receive an overall performance evaluation.

PROCESS EVALUATION

(EVALUATOR NOTE: Place a check mark in the "Yes" or "No" blanks to designate whether or not the student has satisfactorily achieved each step in this procedure. If the student is unable to achieve this competency, have the student review the materials and try again.)

The student:	YES	NO
1. Prepared furnace door for testing.	<input type="checkbox"/>	<input type="checkbox"/>
2. Used draft gauge properly to determine overfire draft.	<input type="checkbox"/>	<input type="checkbox"/>
3. Recorded overfire draft in inches of water column.	<input type="checkbox"/>	<input type="checkbox"/>
4. Evaluated overfire draft measurement.	<input type="checkbox"/>	<input type="checkbox"/>
5. Completed flue draft test properly.	<input type="checkbox"/>	<input type="checkbox"/>
6. Recorded flue draft in inches of water column.	<input type="checkbox"/>	<input type="checkbox"/>
7. Evaluated flue draft measurement.	<input type="checkbox"/>	<input type="checkbox"/>

Evaluator's comments: _____

JOB SHEET #5 PRACTICAL TEST

PRODUCT EVALUATION

(EVALUATOR NOTE: Rate the student on the following criteria by circling the appropriate numbers. Each item must be rated at least a "3" for mastery to be demonstrated. (See performance evaluation key below.) If the student is unable to demonstrate mastery, student materials should be reviewed and another test procedure must be submitted for evaluation.)

Criteria:	4	3	2	1
Preparation of fire door	4	3	2	1
Overtire draft measurement	4	3	2	1
Flue draft measurement	4	3	2	1
Evaluation of measurements	4	3	2	1

EVALUATOR'S COMMENTS: _____

PERFORMANCE EVALUATION KEY

- 4 — **Skilled** — Can perform job with no additional training.
- 3 — **Moderately skilled** — Has performed job during training program; limited additional training may be required.
- 2 — **Limited skill** — Has performed job during training program; additional training is required to develop skill.
- 1 — **Unskilled** — Is familiar with process, but is unable to perform job.

(EVALUATOR NOTE: If an average score is needed to coincide with a competency profile, total the designated points in "Product Evaluation" and divide by the total number of criteria.)

OIL-FIRED FURNACES UNIT XI

PRACTICAL TEST #6 JOB SHEET #6 — PERFORM FUEL PUMP SERVICE ON AN OIL-FIRED FURNACE

Student's name _____ Date _____

Evaluator's name _____ Attempt no. _____

Student instructions: When you are ready to perform this task, ask your instructor to observe the procedure and complete this form. All items listed under "Process Evaluation" must receive a "Yes" for you to receive an overall performance evaluation.

PROCESS EVALUATION

(EVALUATOR NOTE: Place a check mark in the "Yes" or "No" blanks to designate whether or not the student has satisfactorily achieved each step in this procedure. If the student is unable to achieve this competency, have the student review the materials and try again.)

The student:	YES	NO
1. Removed and replaced in-line fuel filter.	<input type="checkbox"/>	<input type="checkbox"/>
2. Removed strainer and cap assembly on fuel pump.	<input type="checkbox"/>	<input type="checkbox"/>
3. Cleaned and reassembled strainer and cap assembly.	<input type="checkbox"/>	<input type="checkbox"/>
4. Used test gauge to set regulator pressure to 100 PSI.	<input type="checkbox"/>	<input type="checkbox"/>
5. Installed gauge in nozzle discharge port.	<input type="checkbox"/>	<input type="checkbox"/>
6. Turned furnace off and observed pressure drop.	<input type="checkbox"/>	<input type="checkbox"/>
7. Evaluated all readings.	<input type="checkbox"/>	<input type="checkbox"/>
8. Bled fuel line of air at bleed port on fuel pump.	<input type="checkbox"/>	<input type="checkbox"/>

Evaluator's comments: _____

JOB SHEET #6 PRACTICAL TEST

PRODUCT EVALUATION

(EVALUATOR NOTE: Rate the student on the following criteria by circling the appropriate numbers. Each item must be rated at least a "3" for mastery to be demonstrated. (See performance evaluation key below.) If the student is unable to demonstrate mastery, student materials should be reviewed and another test procedure must be submitted for evaluation.)

Criteria:

Filter replacement	4	3	2	1
Strainer cleaning	4	3	2	1
Pressure adjustments	4	3	2	1
Fuel line bleeding	4	3	2	1

EVALUATOR'S COMMENTS: _____

PERFORMANCE EVALUATION KEY

- 4 — **Skilled** — Can perform job with no additional training.
- 3 — **Moderately skilled** — Has performed job during training program; limited additional training may be required.
- 2 — **Limited skill** — Has performed job during training program; additional training is required to develop skill.
- 1 — **Unskilled** — Is familiar with process, but is unable to perform job.

(EVALUATOR NOTE: If an average score is needed to coincide with a competency profile, total the designated points in "Product Evaluation" and divide by the total number of criteria.)

**OIL-FIRED FURNACES
UNIT XI**

**PRACTICAL TEST #7
JOB SHEET #7 — PERFORM BURNER MAINTENANCE
ON AN OIL-FIRED FURNACE**

Student's name _____ Date _____

Evaluator's name _____ Attempt no. _____

Student instructions: When you are ready to perform this task, ask your instructor to observe the procedure and complete this form. All items listed under "Process Evaluation" must receive a "Yes" for you to receive an overall performance evaluation.

PROCESS EVALUATION

(EVALUATOR NOTE: Place a check mark in the "Yes" or "No" blanks to designate whether or not the student has satisfactorily achieved each step in this procedure. If the student is unable to achieve this competency, have the student review the materials and try again.)

The student:	YES	NO
1. Replaced nozzle as required.	<input type="checkbox"/>	<input type="checkbox"/>
2. Checked nozzle spray angle and centering.	<input type="checkbox"/>	<input type="checkbox"/>
3. Checked and verified electrode settings with manufacturer's specifications.	<input type="checkbox"/>	<input type="checkbox"/>
4. Checked porcelain insulators for cracks.	<input type="checkbox"/>	<input type="checkbox"/>
5. Lubricated oil burner motor to specifications.	<input type="checkbox"/>	<input type="checkbox"/>
6. Cleaned burner blower with shop vac.	<input type="checkbox"/>	<input type="checkbox"/>
7. Lubricated air handling blower motor to specifications.	<input type="checkbox"/>	<input type="checkbox"/>
8. Cleaned air handling blower wheel and replaced air handling filters.	<input type="checkbox"/>	<input type="checkbox"/>

Evaluator's comments: _____

JOB SHEET #7 PRACTICAL TEST

PRODUCT EVALUATION

(EVALUATOR NOTE: Rate the student on the following criteria by circling the appropriate numbers. Each item must be rated at least a "3" for mastery to be demonstrated. (See performance evaluation key below.) If the student is unable to demonstrate mastery, student materials should be reviewed and another test procedure must be submitted for evaluation.)

 Criteria:

Nozzle service/ replacement	4	3	2	1
Electrode service	4	3	2	1
Lubrication	4	3	2	1
Cleaning and filter replacement	4	3	2	1

 EVALUATOR'S COMMENTS: _____

PERFORMANCE EVALUATION KEY
4 — Skilled — Can perform job with no additional training. 3 — Moderately skilled — Has performed job during training program; limited additional training may be required. 2 — Limited skill — Has performed job during training program; additional training is required to develop skill. 1 — Unskilled — Is familiar with process, but is unable to perform job.

(EVALUATOR NOTE: If an average score is needed to coincide with a competency profile, total the designated points in "Product Evaluation" and divide by the total number of criteria.)

**OIL-FIRED FURNACES
UNIT XI**

TEST

Name _____ Score _____

1. Match the terms on the right with their correct definitions.

- | | | | |
|----------|---|-----|--------------------------------|
| _____ a. | The flue outlet to which the stack or flue pipe is connected | 1. | Nozzle |
| _____ b. | A device whose electrical resistance decreases in the presence of light | 2. | Draft regulator |
| _____ c. | The tendency for heated air to rise in a duct or other vertical air passage | 3. | Stack switch |
| _____ d. | A conductor having a high heat resistance, used to form the spark gap for an oil burner ignition system | 4. | Breeching |
| _____ e. | An oil burner using a high-pressure pump and nozzle to break the oil into a fine spray | 5. | Primary control |
| _____ f. | Domestic heating oil classified as #1 for outdoor storage tanks and #2 for indoor storage tanks | 6. | Stack temperature |
| _____ g. | The small fitting on the nose of a gun type oil burner which regulates the flow of oil and breaks the oil into a fine spray | 7. | Cadmium cell |
| _____ h. | A device to sense flue gas temperature on oil-burning equipment; activates the primary control safety circuit in the event of flame failure | 8. | Coke trees |
| _____ i. | The temperature of the flue gases taken at a point between the breeching and the draft regulator | 9. | Chimney effect |
| _____ j. | The combustion area of the primary section of the heat exchanger that has a fire-resistant liner | 10. | Combustion chamber |
| _____ k. | A reference to the build up of carbon on the surface of the combustion chamber | 11. | Electrode |
| | | 12. | Fuel oil |
| | | 13. | High-pressure atomizing burner |

TEST

- ____l. A device in the vent to maintain a stable or fixed draft through the heating equipment within the limits of available draft of the chimney
- ____m. A device that supervises starting, running, stopping, and emergency shut-down of an oil-fired burner
2. Match oil furnace types with their performance characteristics.
- | | |
|--|------------------|
| ____a. Air flows upward through the furnace | 1. Counterflow |
| ____b. Air blows downward through the furnace with the blower above the heat exchanger | 2. Floor furnace |
| ____c. Air flows through the furnace from one end to the other | 3. Horizontal |
| ____d. Installed flush with the floor to provide gravity heat | 4. Upflow |
3. Solve problems concerning oil storage tanks. Select the best solution to each of the following problems.
- a. A customer changing to an oil-fired system has the choice of using an indoor or an outdoor tank. In order to provide the customer with maximum efficiency, you should recommend what? ____.
- 1) An outdoor tank
 - 2) An indoor tank
 - 3) An underground outdoor tank
- b. A customer has no basement room for an indoor tank and the only available outside location is more than 30 feet from where the new furnace will sit. You know the system will demand what? ____.
- 1) A gravity feed system to cut down installation costs
 - 2) A forced feed system with both a supply and return line
 - 3) A better location for the furnace

TEST

4. Identify the major components of an oil burner assembly. Write the component name in the appropriate blank.

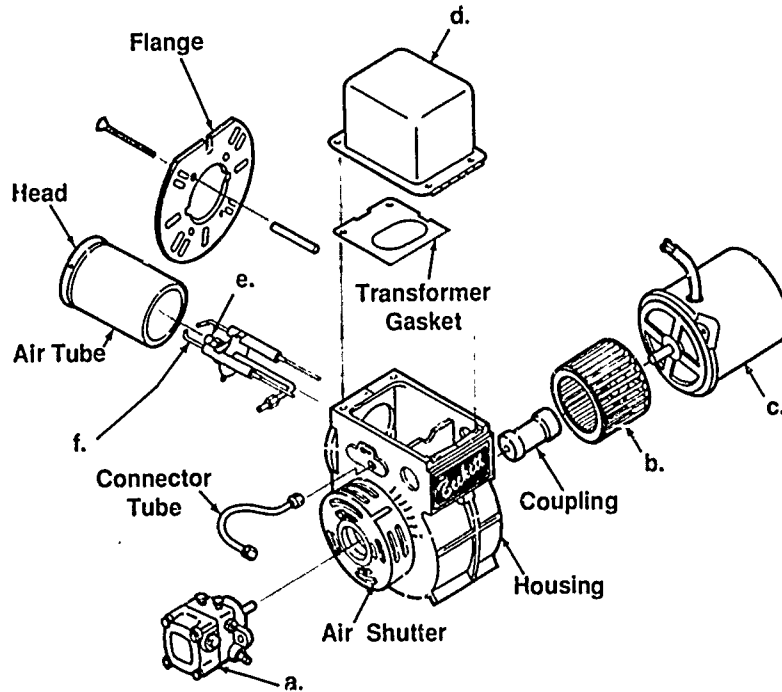

- a. _____
- b. _____
- c. _____
- d. _____
- e. _____
- f. _____

TEST

5. Complete statements concerning the operation of a gun-type atomizing burner. Circle the material that best completes each statement.
- Fuel pump delivers oil (under pressure) (with gravity feed) to a precision made nozzle.
 - The oil is broken up at the nozzle into a fine (cone-shaped) (jet-spray) mist.
 - The pump motor also drives a blower which supplies a (fresh air supply) (turbulent stream of air) to the burner at the point where the nozzle is spraying oil.
 - The atomized mixture is readily ignited by (a carbon arc) (an electric spark) supplied by an ignition transformer through an ignition electrode assembly.
6. Solve problems concerning flame retention. Select the best solution to each of the following problems.
- A customer wants to know why a flame retention burner will improve furnace efficiency. You should _____.
 - Explain the technology behind flame retention.
 - Explain that flame retention is the modern way to control combustion.
 - Point out that flame retention reduces combustion volume, gives higher combustion temperatures, and reduces stack draft problems.
 - Flame retention is built around a high pressure drop of combustion air that occurs at the burner head. A customer wants to know what this accomplishes. You should say _____.
 - The high pressure drop will cause a high velocity rotating motion to the combustion air as it exits the head.
 - The high pressure drop will create a suction that will help concentrate the flame and improve combustion.
 - The high pressure drop will improve the action of the electrode spark and improve combustion.
 - You have just explained the technical aspects of flame retention to a customer, but the customer wants you to explain it in plain English. You should say _____.
 - Flame retention saves fuel, gives off fewer pollutants, requires less burner maintenance, and gives better overall performance.
 - It saves you money.
 - It keeps you warmer.

TEST

7. Select true statements concerning visual flame detection and cad cell location. Place an "X" beside each true statement.

(NOTE: For a statement to be true, all parts of the statement must be true.)

- ____ a. Basic primary control functions
- 1) Responds to requirements from the thermostat
 - 2) Shuts the burners off on limit action
 - 3) Supervises burner operation
 - 4) Proves the flame
 - 5) Controls the ignition and oil valve
 - 6) Shuts down on a system malfunction
- ____ b. Cad cell location
- 1) Is a critical factor in performance of the cad cell
 - 2) Must be mounted in the burner where it has a direct open line of sight to the flame in order to "see" the oil flame
 - 3) Usually mounted in the rear of the burner to be protected from excessive heat
 - 4) Since cad cell resistance decreases in the presence of light, adequate light must reach the cell.
 - 5) Light, not heat makes the cad cell work and ambient temperatures must be below 140°F.
 - 6) The cell must be protected from external light and must have adequate clearance from metal surfaces that could cause shielding or heat radiation.
- ____ c. Cad cell operation
- 1) Cad cell monitors the light given off by the flame.
 - 2) Resistance increases when there is no light.
 - 3) Resistance decreases in the presence of light.

TEST

8. Complete statements concerning troubleshooting cad cell systems. Circle the material that best completes each statement.
- a. Check out the light cell with the following procedure:
 - 1) Remove cad cell lead wires from the (entrance) (primary) control.
 - 2) Start the burner and then jumper the main primary control terminals to permit the burner (to run) (to remain off).
 - 3) Connect cad cell lead wires to the ohmmeter and look for a reading of less than (1600 ohms) (16,000 ohms).
 - b. Check out the dark cell with the following procedure:
 - 1) Stop the burner and (remove) (leave) the jumper from the main primary control terminals.
 - 2) Leave cad cell lead wires connected to ohmmeter and look for a reading of (100,00) (10,000) ohms or more.
 - c. Always check the cad cell when it appears there is an open circuit in the (flame detector circuit) (primary control).
 - d. Vibration can cause a cad cell to move out of place so always check for (proper seating) (general placement).
 - e. There is (little) (quite a bit of) actual service that can be done on the cad cell itself, but the face of the cell can be cleaned to make sure the electrode and conductive grid are free of build-up.
9. Complete statements concerning combustion chambers. Circle the material that best completes each statement.
- a. Function
 - 1) (Surround) (induce) the flame.
 - 2) Radiate heat (ahead of) (back into) the flame to aid in combustion.
 - b. Design
 - 1) Must be made of the (metal) (correct) material.
 - 2) Must be properly sized for the (nozzle) (system) firing rate.
 - 3) Must be (sized) (shaped) correctly.
 - 4) Must be the proper (height) (width).

TEST

- c. Requirements
- 1) Has to withstand (intense heat) (repeated firing).
 - 2) Must heat up (relatively fast) (quickly).
10. Select true statements concerning fuel pumps. Place an "X" beside each true statement.
- a. A fuel pump is a two-stage unit.
 - b. A single-stage fuel pump has two sets of gears.
 - c. A single-stage unit is usually used where the supply tank is above the burner.
 - d. The single-stage unit draws oil from the tank directly and delivers it to the nozzle under sufficient pressure to properly atomize the oil for combustion.
 - e. A two-stage fuel pump has one set of gears.
 - f. The suction gears in a two-stage pump draw oil from a submerged tank or a tank located below the level of the oil burner.
 - g. The pressure gearset delivers oil under pressure to the burner nozzle.
 - h. Since the pressure gearset does not have to do any lifting to supply the oil, it can totally dedicate its service to properly atomizing the fuel.
11. Select true statements concerning nozzles. Place an "X" beside each statement that is true.
- a. Nozzles in general are rated as Type A nozzles which produce a hollow spray pattern or Type B which produce a solid spray pattern.
 - b. Nozzles are rated in firing rate and the spray angle is stamped on the nozzle.
 - c. The hollow air pattern produces a hollow air spray with no measurable air velocity at the center of the pattern.
 - d. The solid air pattern produces a moderate solid air spray with definite measurable air velocity at the center of the pattern.
 - e. For burners with flow rates up to 2.00 gph hollow cone nozzles can be used successfully, and on smaller burners, the hollow cone nozzles give the quietest service.

TEST

- _____ f. For burners with flow rates between 2.00 and 3.00 gph, either a hollow cone or solid cone nozzle can be used depending on burner air pattern.
- _____ g. For burners with flow rates above 3.00 gph, hollow cone nozzles usually produce smoother ignition at higher flow rates, but some systems do use solid cone nozzles.
12. Solve problems concerning nozzle service guidelines. Select the best solution to each of the following problems.
- a. You are servicing a system at the beginning of the heating season and the customer wants you to clean the old nozzle instead of replacing it. You should respond _____.
- 1) By telling the customer that a new nozzle assures better performance and that cleaning the old nozzle risks damage and could take a long time.
 - 2) By doing exactly what the customer requests because the customer is always right.
 - 3) By calling the boss to get an outside opinion.
- b. You are working with a co-worker who has taken a brand new nozzle out of its box and is blowing into the nozzle to make sure it is clean. You should _____.
- 1) Acknowledge that your co-worker is doing the right thing.
 - 2) Tell your co-worker to be careful not to get grease on the nozzle.
 - 3) Tell your co-worker that blowing on the nozzle can contaminate it because it has been assembled and packaged to be absolutely clean on delivery.
- c. You are preparing to install a new nozzle and even have the proper installation tool, but you should do what else first? _____.
- 1) Double check the nozzle angle.
 - 2) Flush the nozzle line.
 - 3) Make sure the nozzle is really clean by sticking a fine pin into the orifice.

TEST

13. Complete statements concerning venting. Circle the material that best completes each statement.
- a. Must convey hot combustion gases to the (outside) (combustion chamber).
 - b. Must protect the structure from fire hazards due to (overheating) (combustion gas leaks).
 - c. Must prevent the escape of combustion gases into the (occupied space) (flue).
 - d. Must be made of material approved for (an oil-fired furnace) (general furnace use).
14. Select true statements concerning normal operating sequence. Place an "X" beside each true statement.
- a. Thermostat calls for heat.
 - b. Current flows to the burner motor only.
 - c. A current flow exists through the dark cad cell and the safety switch heater.
 - d. Immediately, the ignition transformer establishes a spark across the electrodes by the nozzle.
 - e. The oil burner blower reaches full speed, blowing the spark forward igniting the oil spray quickly expanding into a full burst of fire in the combustion chamber.
 - f. Light from the flame reaches the cad cell and causes the safety to open.
 - g. Flame efficiency increases as the combustion chamber temperature rises, reaching a white-hot surface temperature when the burner is operating at peak efficiency.
 - h. Thermostat is satisfied.
 - i. Current flow is interrupted.
 - j. Operation ceases with the exception of the furnace air circulating blower motor which will stop after residual heat is dissipated.

TEST

15. Solve problems concerning electrodes. Select the best solution to each of the following problems.
- a. In servicing a system you have checked the electrodes as they are centered over the nozzle and as they are distanced from the center of the nozzle. You next item of service should be to _____.
- 1) Check for cracks in the insulators.
 - 2) Check for cracks under the electrode brackets.
 - 3) Check the distance the electrodes extend in front of the nozzle.
- b. A customer inquires how electrode settings are determined. You should say _____.
- 1) Strictly by the gallons per hour of fuel consumption.
 - 2) According to the degrees of the nozzle spray pattern.
 - 3) According to how hot the stack temperature gets.
- c. You have completed checking electrode settings and checked for cracks under the electrode brackets, but you still need to _____.
- 1) Look for cracked insulators or a coat of soot or oil than can cause erratic conducting.
 - 2) Look for electrodes that have vibrated out of place.
 - 3) Look for an oil build-up in the retention chamber.
16. Complete statements concerning combustion testing. Circle the material that best completes each statement.
- a. Combustion testing determines if a furnace is operating properly and (safely) (efficiently).
- b. Good combustion testing requires the proper instruments, recording test results, and comparing results with (previous tests) (manufacturer's specifications).
- c. The overfire draft test requires a draft gauge to read the draft over the fire just beyond the inner edge of the (combustion chamber) (electrode gun).
- d. The stack draft requires a draft gauge to measure the draft (behind) (ahead of) the draft regulator.
- e. The percent CO₂ test requires a CO₂ analyzer to obtain an air sample far enough ahead of the draft control to assure no (oil residue) (outside air) is mixed with it.

TEST

- f. The smoke test requires a smoke tester to take a vent sample just (ahead of) (behind) the draft regulator.
 - g. The stack temperature measurement should be made in the vent just ahead of the draft regulator, and the thermometer needs to be of special design so it can reach into the (center third) (bottom half) of the flue pipe diameter.
 - h. The temperature rise measurement requires taking a measurement of supply air temperature with a (special) (regular service) thermometer at a point close to the furnace, then subtracting that ambient temperature from the stack temperature.
 - i. Combustion efficiency requires complete combustion testing, and charts or hand-held slide rules should be used to (determine the percent efficiency) (Make reliable comparisons).
17. Match burner components and required maintenance.
- | | | | |
|--------|---|----|--------------------|
| ___ a. | Should be oiled twice a year. | 1. | Nozzle |
| ___ b. | Oil filter cartridge should be replaced each year. | 2. | Blower |
| ___ c. | Should be changed before start up of each heating season. | 3. | Motor |
| ___ d. | Should be checked once a year. | 4. | Replacements |
| ___ e. | Must be kept free of dirt and lint. | 5. | Filter |
| ___ f. | Always use parts recommended by the manufacturer. | 6. | Electrode settings |

(NOTE: If the following activities have not been accomplished prior to the test, ask your instructor when they should be completed.)

18. Demonstrate the ability to:
- a. Install an oil-fired furnace. (Job Sheet #1)
 - b. Perform a stack temperature test on an oil-fired furnace. (Job Sheet #2)
 - c. Perform a CO₂ test and determine the combustion efficiency of an oil-fired furnace. (Job Sheet #3)
 - d. Perform a smoke test on an oil-fired furnace. (Job Sheet #4)
 - e. Perform an "overfire draft" and a "flue draft" test on an oil-fired furnace. (Job Sheet #5)
 - f. Perform fuel pump service on an oil-fired furnace. (Job Sheet #6)

**OIL-FIRED FURNACE
UNIT XI**

ANSWERS TO TEST

1. a. 4 f. 12 k. 8
 b. 7 g. 1 l. 2
 c. 9 h. 3 m. 5
 d. 11
 e. 13 j. 6
 10

2. a. 4
 b. 1
 c. 3
 d. 2

3. a. 2)
 b. 2)

4. a. Fuel pump
 b. Blower
 c. Motor
 d. Ignition transformer
 e. Nozzle
 f. Ignition electrodes

5. a. Under pressure
 b. Cone-shaped
 c. Turbulent stream of air
 d. An electric spark

6. a. 3)
 b. 1)
 c. 1) is preferred, 2) is acceptable

7. a, b, c (all statements are true)

8. a. 1) Primary
 2) To run
 3) 1600 ohms
 b. 1) Remove
 2) 100,000
 c. Flame detector circuit
 d. Proper seating
 e. Little

ANSWERS TO TEST

9. a. 1) Surround
2) Back into
b. 1) Correct
2) Nozzle
3) Shaped
4) Height
c. 1) Intense heat
2) Quickly
10. c, d, f, g, h
11. a, c, d, e, f
12. a. 1)
b. 3)
c. 2)
13. a. Outside
b. Overheating
c. Occupied space
d. An oil-fired furnace
14. a, c, d, e, g, h, i, j
15. a. 3)
b. 2)
c. 1)
16. a. Efficiently
b. Manufacturer's specifications
c. Combustion chamber
d. Ahead of
e. Outside air
f. Ahead of
g. Center third
h. Regular service
i. Determine the percent efficiency
17. a. 3
b. 5
c. 1
d. 6
e. 2
f. 4

ANSWERS TO TEST

18. a. Evaluated according to criteria in Practical Test #1
b. Evaluated according to criteria in Practical Test #2
c. Evaluated according to criteria in Practical Test #3
d. Evaluated according to criteria in Practical Test #4
e. Evaluated according to criteria in Practical Test #5
f. Evaluated according to criteria in Practical Test #6

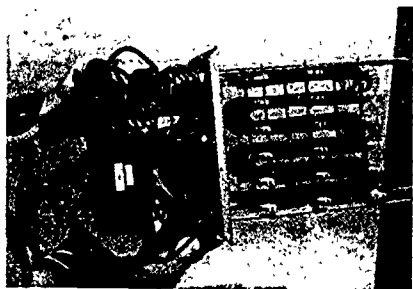

ELECTRICAL HEATING SYSTEMS UNIT XII

UNIT OBJECTIVE

After completion of this unit, the student should be able to install, start, troubleshoot, and maintain an electric furnace. These competencies will be demonstrated by completing the job sheets and by scoring a minimum of 85 percent on the written test.

SPECIFIC OBJECTIVES

After completion of this unit, the student should be able to:

1. Match terms related to electrical heating systems with their correct definitions.
2. Identify types of electrical heating systems.
3. Differentiate between duct heaters and electric furnaces.
4. Complete a list of components of electric heating equipment.
5. Select true statements concerning causes of common failures of electric heating equipment components.
6. Match staging methods with their operations.
7. Complete statements concerning installing duct heaters.
8. Solve problems concerning installing heaters smaller or larger than ductwork.
9. Solve problems concerning installing slip-in heaters.
10. Solve problems concerning installing flange-type heaters.
11. Select true statements concerning general recommendations for installing duct heaters.
12. Solve problems concerning gathering information for system sizing.
13. Use formulas for sizing electrical heating systems.

SPECIFIC OBJECTIVES

14. Demonstrate the ability to:
 - a. Install, start, and check an electrical heating unit. (Job Sheet #1)
 - b. Disassemble, inspect, and reassemble an electric furnace. (Job Sheet #2)
 - c. Troubleshoot an electric furnace. (Job Sheet #3)
 - d. Perform maintenance on an electric furnace. (Job Sheet #4)

555

ELECTRICAL HEATING SYSTEMS UNIT XII

SUGGESTED ACTIVITIES

- A. Obtain additional materials and/or invite resource people to class to supplement/reinforce information provided in this unit of instruction.

(NOTE: This activity should be completed prior to the teaching of this unit.)

- B. Make transparencies from the transparency masters included with this unit.
- C. Provide students with objective sheet.
- D. Discuss unit and specific objectives.
- E. Provide students with information sheets.
- F. Discuss information sheets.

(NOTE: Use the transparencies as needed to enhance the information.)

- G. Provide students with job sheets.
- H. Discuss and demonstrate the procedures outlined in the job sheets.
- I. Integrate the following activities throughout the teaching of this unit:
1. Show the class samples of electric furnace sequencers; they do not have to be in a serviceable condition.
 2. Arrange a field trip to a location (commercial if possible) that has an electric heating system.
 3. Review Ohm's Law and discuss its use in determining wattage in relation to Objective XII.
 4. Meet individually with students to evaluate their progress through this unit of instruction, and indicate to them possible areas for improvement.
- J. Give test.
- K. Evaluate test.
- L. Reteach if necessary.

REFERENCES USED IN DEVELOPING THIS UNIT

- A. Althouse, Andrew D., and Carl H. Turnquist and Alfred F. Bracciano. *Modern Refrigeration and Air Conditioning*. South Holland, IL 60473: The Goodheart-Willcox Company, 1988.
- B. Whitman, William C., and William M. Johnson. *Refrigeration and Air Conditioning Technology*. Albany, NY 12212: Delmar Publishers, Inc., 1987.
- C. "Installation Manual for DHA, DHB, DHC, and DHD Series Nykelkrom® Duct Heaters." Cookeville, TN 38501: Tutco, Inc., no date.

**ELECTRIC HEATING SYSTEMS
UNIT XII****INFORMATION SHEET****I. Terms and definitions**

- A. **Nichrome** — An alloy used extensively as a heat source for electric resistance heat
- B. **Contactor** — A relay capable of opening and closing circuits of high amperage
- C. **Line Voltage** — The power, such as 240V, supplied to a heater
- D. **Fan relay** — A relay that operates a furnace blower, frequently incorporated with the first stage heating sequencer of an electric furnace
- E. **Power lugs** — Heavy duty fittings for connecting power wires to a high amperage appliance such as an electric furnace
- F. **High limit switch** — A safety device that opens the circuit when there is excessive temperature rise
- G. **Fusible link** — A backup safety device designed to melt at a specified temperature higher than the regular limit switch, thereby opening the circuit
- H. **Air sensing switch** — A switch that senses the air pressure in a duct and allows the heaters to be energized only when air is moving over the elements
- I. **Sail switch** — A switching device with a "sail" mounted to a moveable arm in the duct allowing heater operation when there is air flowing
- J. **SCR (silicon controlled rectifier)** — Solid state device incorporated into electric duct heaters to control the heat output by varying the time the heater is "on" by using electronic time proportioning
- K. **Sequencer** — A device to open or close a circuit by allowing time (usually a few seconds) to elapse after a heater is energized or de-energized

(NOTE: By using sequencers the load may be brought on in stages keeping the initial high current draw to a minimum.)

- L. **Staging** — A control strategy for bringing heating elements on as they are needed in relation to temperature drop

EXAMPLE: A two-stage thermostat turns the first heating elements on when the temperature drops 2°F below a set point and turns on second elements when temperature drops 4°F below a set point.

- M. **Balance point** — The point, expressed in °F, where the heat pump capacity is equal to or balanced with the heat loss of the structure

INFORMATION SHEET

- N. **Time delay relay** — A device, usually solid state, used to open or close a circuit within a specific time after the circuit has been energized or de-energized

II. Types of electrical resistance heating systems

- A. Duct heaters (Transparency 1)
B. Electric Furnaces (Transparencies 2 and 3)

III. Characteristics of electrical heating systems

- A. Duct heaters (Transparency 1)
1. Composed of nichrome wire coil strung through insulators
 2. Placed in a heating duct with remote blower
 3. Equipped with line voltage controls
 - a. Contactor switch
 - b. Line voltage high limit safety (fusible link)
 4. Equipped with low voltage controls
 - a. Contactor coil
 - b. Low voltage high limit safety (snap action switch)
 5. Installed four feet downstream from cooling coil unless approved for use as integral part of equipment
- B. Electric Furnaces (Transparencies 2 and 3)
1. Composed of one or more nichrome wire heating elements
 2. Consists of self-contained complete system with:
 - a. Blower assembly
 - b. Electric heating elements
 - c. Line voltage and low voltage controls vary with manufacturer

IV. Components of electric heating equipment

- A. Blower assembly
B. Heater element assembly
1. Nichrome wire coils installed through insulators in path of air stream

INFORMATION SHEET

2. Fusible link in line voltage circuit of heater coil exposed to radiant heat of heater element
 3. High temperature limit controls vary with manufacturer
- C. Electric heat circuits and controls
1. Low voltage fan circuit
 - a. Transformer
 - b. Thermostat
 - c. Fan relay coil or sequencer heater
 2. Line voltage fan circuit
 - a. Blower motor
 - b. Fan relay contacts or sequencer contacts
 - c. Fuse or breaker
 3. Low voltage heater circuits
 - a. Transformer (some are fused)
 - b. Thermostat
 - c. Contactor coil or sequencer heater
 - d. High limit switch
 4. Line voltage heater circuit
 - a. Heater element
 - b. Fusible link
 - c. Contactor contacts or sequencer contacts
 - d. Fuse or breaker
- V. Causes of failures of electric heating equipment components
- A. Heating element circuit open
1. Melted fusible link
 2. Nichrome wire burned in two because of:
(NOTE: Insufficient air flow is a problem.)

INFORMATION SHEET

- a. Dirty filter
 - b. Undersized ductwork or too many outlets closed
 - c. Dirty cooling coil or blower
 - d. Broken insulator
- B. Burned out sequencer
 - C. Stuck limit switch
 - D. Burned out transformer
 - E. Loose connections

(CAUTION: When aluminum wire is found in an electrical heating unit, it should be removed and replaced with copper wire.)

VI. Staging methods and their operations

- A. Two-stage wall thermostat — First stage turns on some elements until the temperature in a space begins to drop, and the second stage turns on remaining heating elements
- B. Outdoor thermostat — Wired into the control circuit to part of the heating elements which are kept off until the temperature drops below a balance point in a heat pump system
- C. SCR (silicon controlled rectifier) — Controls heat by varying the time the elements are on

(NOTE: There are other staging strategies, but the ones listed are the most common.)

VII. Installing duct heaters

- A. Duct heaters should be installed at least four feet downstream from an air handler and four feet downstream from heat pumps or air conditioners.
- B. When a canvas duct is used to dampen equipment vibration, the duct heater should be installed at least four feet downstream from the canvas. (Figure 1)

INFORMATION SHEET

FIGURE 1

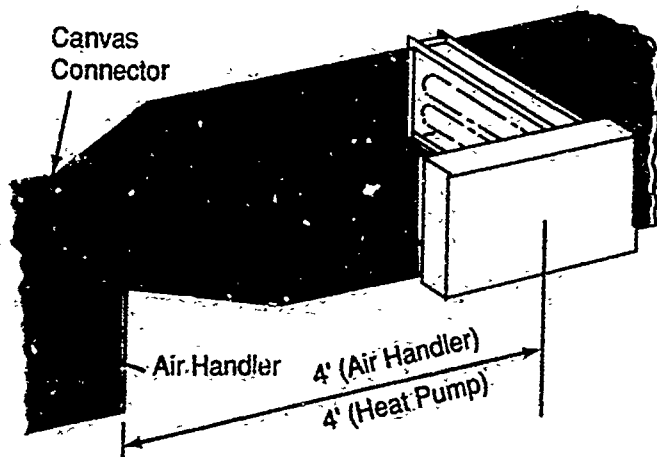

Courtesy Tutco, Inc.

- C. When a heater cannot be placed at least four feet downstream from canvas duct, the canvas should be replaced with metal.
- D. Duct heaters should be installed two feet on either side of an elbow. (Figure 2)
- E. Turning vanes installed in the elbow will reduce pressure losses and insure that air velocity is uniformly distributed over the cross section of the duct. (Figure 2)

FIGURE 2

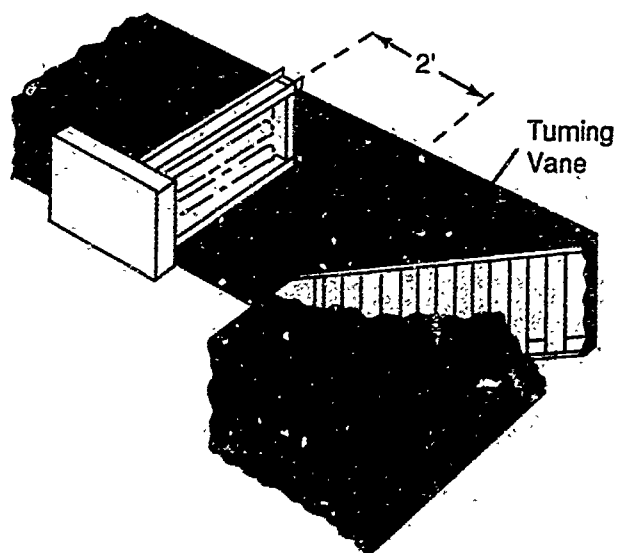

Courtesy Tutco, Inc.

INFORMATION SHEET

- G. The heater should be installed at least four feet from the transition section for a change in duct size.
- H. If splitters are required in the transition section, they should be installed upstream of the heater to insure uniform air flow over the entire face of the heater.

VIII. Installing heaters smaller or larger than ductwork

- A. When a heater is smaller than the ductwork, the open area between the heater frame and the duct must be filled with wire mesh or expanded metal. (Figure 3)
- B. The wire mesh or expanded metal should have an open area of approximately 89 percent and should not exceed 20% of the total duct face area.
- C. The filler material creates a uniform resistance across the face of the duct area to insure adequate air flow through the coils. (Figure 3)

FIGURE 3

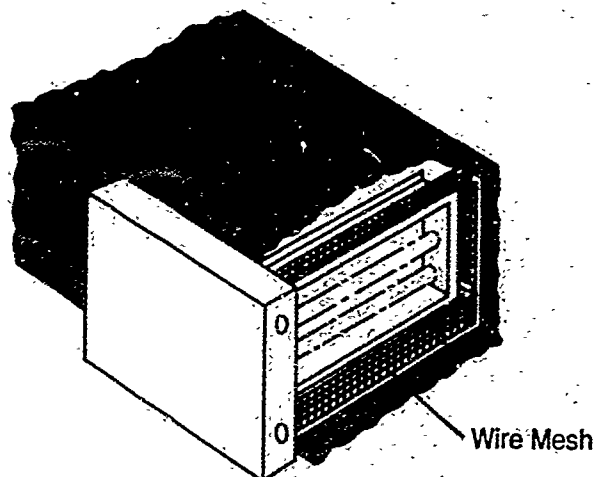

Courtesy Tutco, Inc.

- D. When a heater is larger than ductwork, the duct cross section may be increased by using a sheet metal transition. (Figure 4)
- E. The angle A in the diverging section should be as small as possible and in no case should it exceed 20 degrees. (Figure 4)
- F. In the converging section, angle B should be limited to a maximum of 30 degrees. (Figure 4)

INFORMATION SHEET

FIGURE 4

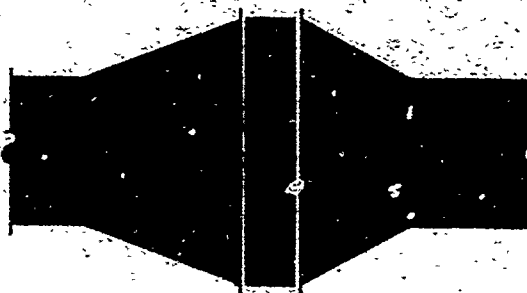

Courtesy Tutco, Inc.

IX. Installing slip-in heaters (Figure 5)

- A. To install a slip-in heater, cut the opening as required in the side of the duct.
- B. Slide the heater into the duct, and use the control box as a template to mark screw holes.
- C. Remove the unit and drill the holes.
- D. Mount the unit to the duct with sheet metal screws.
- E. Connect high and low voltage and fan interlock if no airflow switch is furnished.
- F. A larger heater may require hanger straps.

FIGURE 5

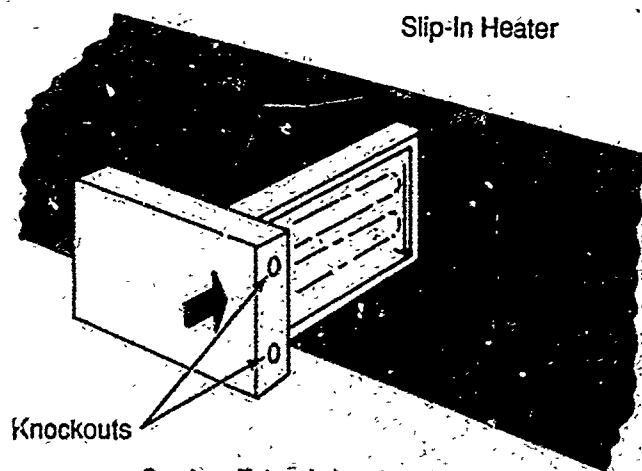

Courtesy Tutco, Inc.

INFORMATION SHEET

- G. When using a slip-in-heater with insulated duct, the frame dimensions should be reduced to match the reduced duct area.
- H. Knowing the insulation thickness, the manufacturer can provide for proper clearance for heater installation and operation.

X. Installing flange-type heaters (Figure 6)

- A. To install a flange-type heater, insert the heater between two sections of flanged duct and bolt it in place.
- B. For additional strength, the duct flange should be doubled, and larger heaters may require hangar straps.

FIGURE 6

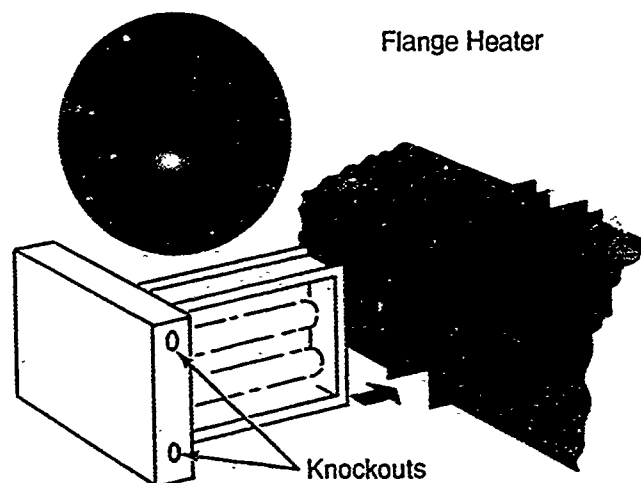

Courtesy Tutco, Inc.

- C. Connect high and low voltage and fan interlock if no airflow switch is furnished.
- D. For flange-type heaters with insulated duct, the frame dimensions are the same as for standard heaters, but the coil area will be reduced to match the reduced free duct area.
- E. Knowing the insulation thickness, the manufacturer can provide for proper installation and operation.

INFORMATION SHEET

XI. General recommendations for installing duct heaters

- A. Heaters may be installed in the sides of either horizontal or vertical duct, but never on the top or bottom of horizontal duct.
- B. Heaters should be installed safe distances from other equipment and according to the rules of four:
 1. Four feet from a heat pump or central air conditioner
 2. Four feet downstream from an air handler
 3. Four feet upstream from a humidifier
 4. Four feet away from a canvas duct connector or a transition change in duct size
- C. At an elbow or turn, a heater should be installed at least two feet away on either side.

XII. Gathering information for system sizing

- A. Sizing an electrical heating system requires knowledge of the output of the heating unit, and the output of resistance heating is expressed in watts.
- B. You can determine watts by using a formula from Ohm's Law:

$$P \text{ (watts)} = E \text{ (volts)} \times I \text{ (amperes)}$$

Example: A 240 volt installation with 10 amps in a resistance element would produce 2400 watts of power because $240 (E) \times 10 (I) = 2400 P$.
- C. Because 100 percent of electrical power converts directly into heat, every watt produces 3.413 Btuh (British thermal units per hour).
- D. To convert watts to Btuh, simply multiply by 3.413.

Example: $100 \times 3.413 = 341.3 \text{ Btuh}$.
- E. To convert Btuh to watts, multiply the Btuh by the factor 0.293.

Example: $341.3 \text{ Btuh} \times 0.293 = 100W \text{ (rounded off)}$.
- F. For calculations the Kilowatt is used, and that means to divide the basic watt calculation by 1 thousand.

Example: $10,000 \div 1,000 = 10 \text{ KW}$

INFORMATION SHEET

- G. Another figure needed for system sizing is temperature rise which is determined by subtracting the temperature of return air from the design temperature of supply air.

Example: If return air is 65°F and the supply air is 100°F, then the temperature rise is 35°F; 100°F (supply air) - 65°F (return air) = 35°F.

- H. CFM for system sizing can usually be determined from manufacturer's literature or from nameplate information.

XIII. Formulas for sizing electrical heating systems

- A. Sizing electrical heating systems requires knowing any two of the following requirements:

1. The KW (kilowatt) requirements of the system
2. The CFM (cubic feet per minute) requirements of the system
3. The TR (temperature rise) requirements of the system

- B. When any two system requirements are known, the other requirement can be determined by adding the mathematical constant 3150 to create a formula.

- C. To determine the KW requirements when CFM and temperature rise are known, use the formula:

$$KW = \frac{CFM \times TR}{3150}$$

Example: A system with a CFM of 2,000 and a TR of 45° would require 28.5 KW; 2,000 (CFM) × 45 (TR) = 90,000, and 90,000 ÷ 3150 = 28.57.

- D. To determine the approximate temperature rise of a duct heater when KW and CFM are known, use the formula:

$$TR = \frac{KW \times 3150}{CFM}$$

Example: A system with a KW requirement of 15 and a CFM of 1,200 would require a TR of slightly more than 39°. 15 (KW) × 3150 = 47,250, and 47,250 ÷ 1,200 = 39.38.

- E. To determine the CFM requirement when KW and TR are known, use the formula:

$$CFM = \frac{KW \times 3150}{TR}$$

Example: A system with a KW requirement of 15 and a temperature rise of 39° would require a CFM of slightly more than 1,200; 15 (KW) × 3150 = 47,250, and 47,250 ÷ 39 = 1,211.

Duct Heater

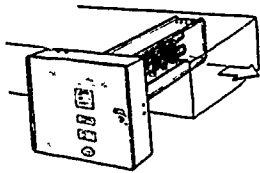
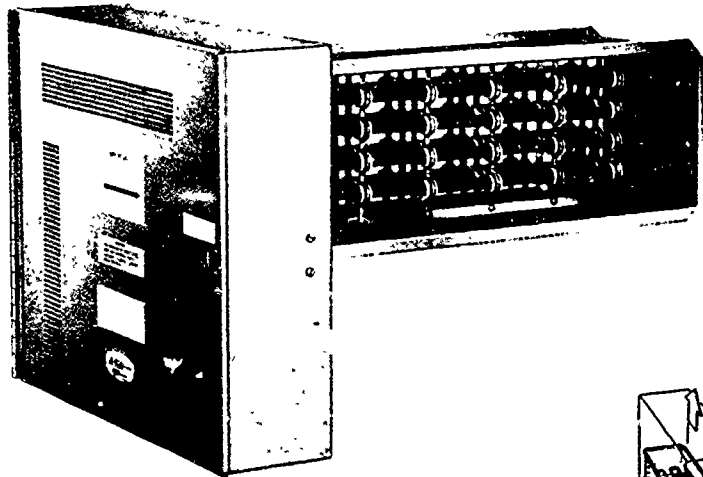

Horizontal Duct Installation

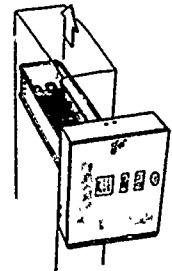

Vertical Duct Installation

Typical Applications

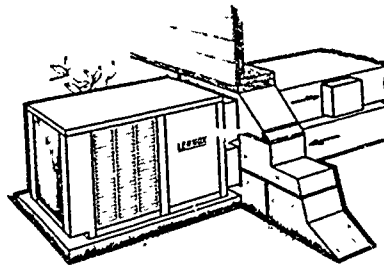

Installed With Single Package Heat Pump or Single Package Air Conditioner

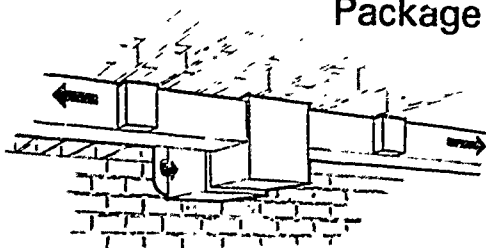

Zone Installation With Centrally Located Filter Unit

Courtesy Lennox Industries, Inc.

568

TM 1

Upflow Electric Furnace

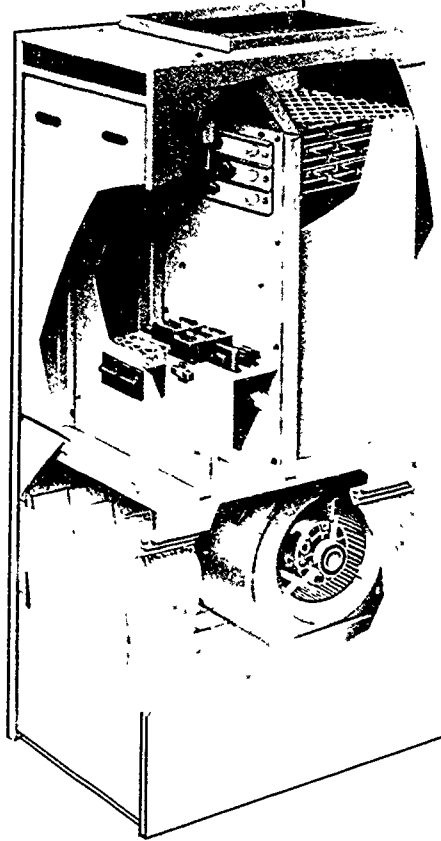

Typical Applications

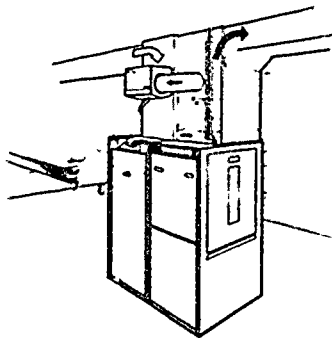

Basement Installation
With Cooling Coil,
Electronic Air Cleaner
and Power Humidifier

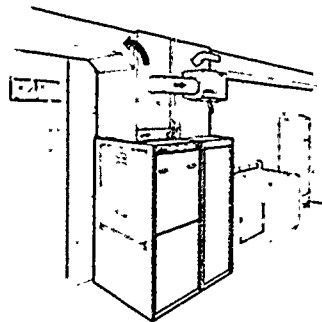

Basement Installation
With Cooling Coil,
Return Air Cabinet
and Power Humidifier

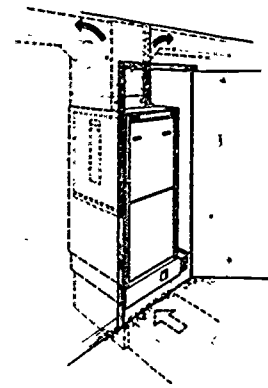

Closet Installation
With Cooling Coil
and Electronic
Air Cleaner

Courtesy Lennox Industries, Inc.

Horizontal Electric Furnace

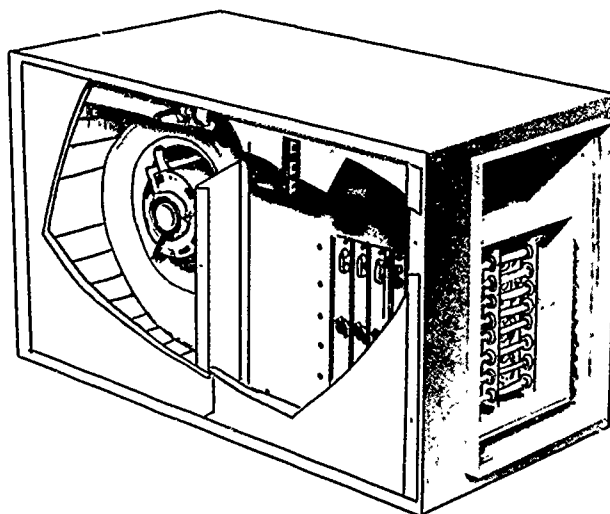

Typical Applications

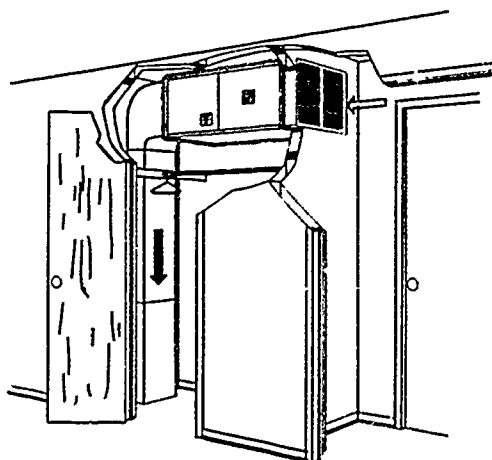

Horizontal Installation in Closet

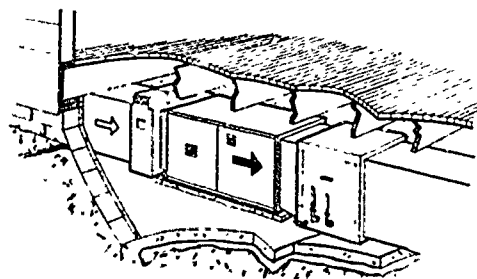

Horizontal Installation
with Cooling Coil
and Electronic Air Cleaner

Courtesy Lennox Industries, Inc.

570

**ELECTRICAL HEATING SYSTEMS
UNIT XII**

HANDOUT #1 — WIRING ELECTRICAL HEATERS

Purpose

Whether an electrical heater is single phase or three phase determines how it should be wired, but back-up protection, power fusing, and fan interlocks have to be taken into account also. In other words, the total system package dictates the necessary wiring. Examining some typical wiring diagrams will help an HVAC technician learn more about electrical installations.

These materials and diagrams are from Tutco, Inc., and are reprinted with permission.

Wiring Diagram #1

The following diagram shows typical wiring for a single phase, single stage heater drawing less than 48 amperes total. The system is shown with contactor for back-up protection and with fan interlock contacts.

Diagram #1

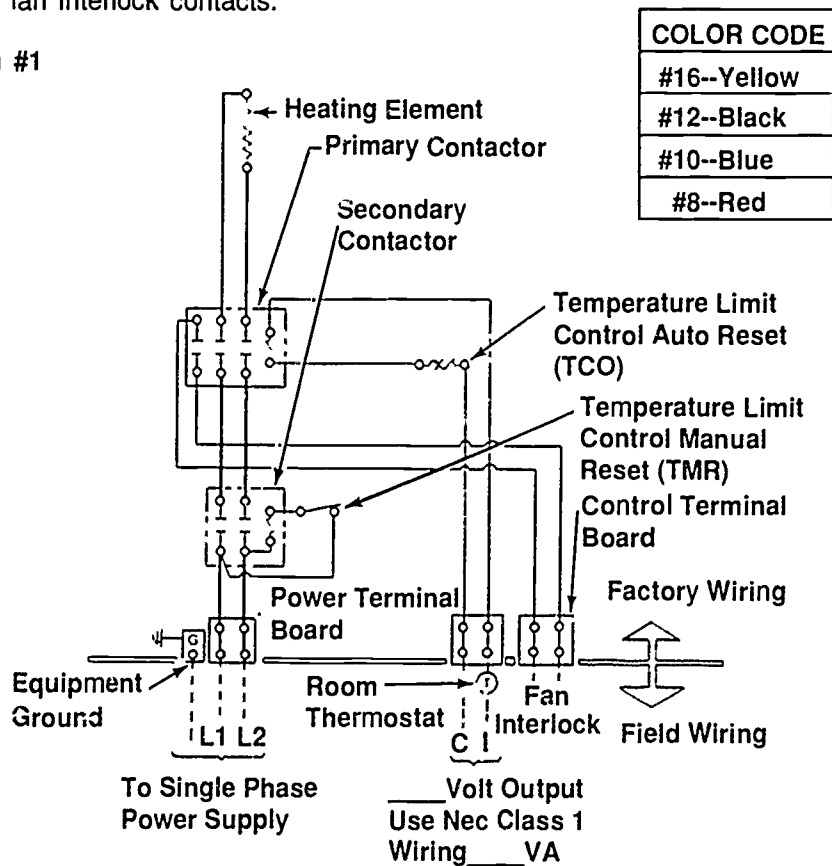

HANDOUT #1

Wiring Diagram #2

The diagram shows typical wiring for a single phase, two stage heater drawing more than 48 amperes total. The system is shown with manual reset used as line break back-up protection, power fusing, and with fan interlock contacts.

Diagram #2

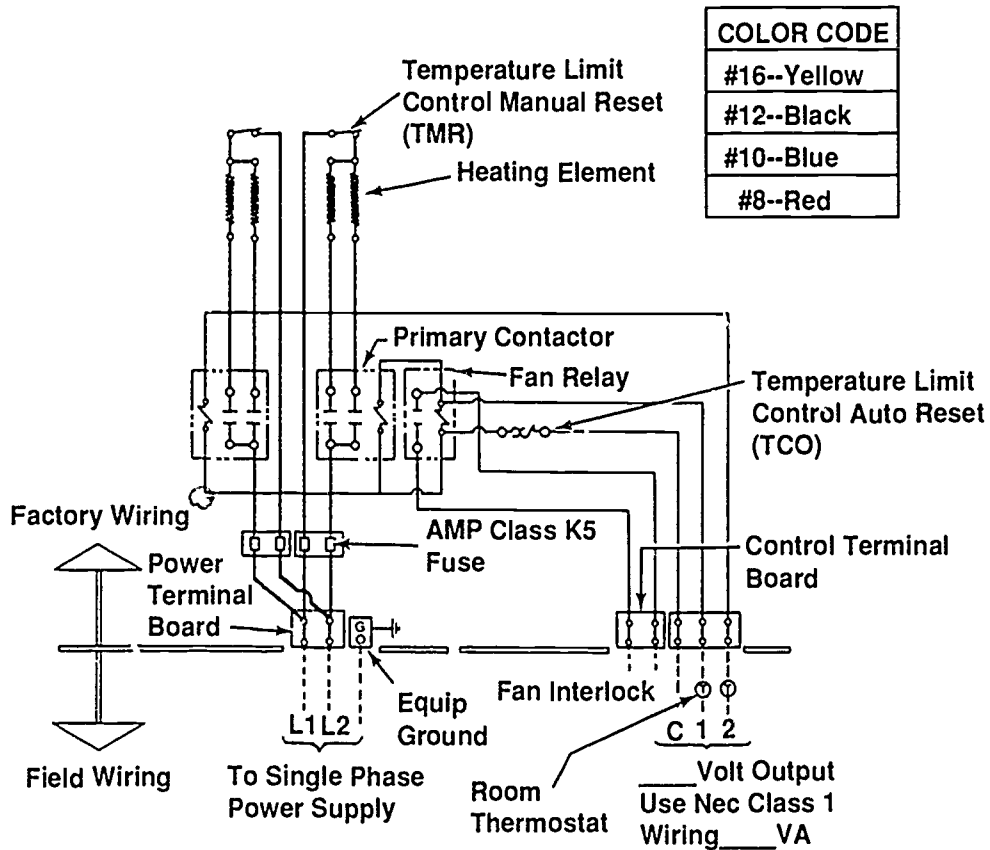

572

HANDOUT #1

Wiring Diagram #3

The diagram shows a single phase, three stage heater drawing less than 48 amperes total. The system is shown with manual reset used as line break back-up protection, and with airflow switch.

Diagram #3

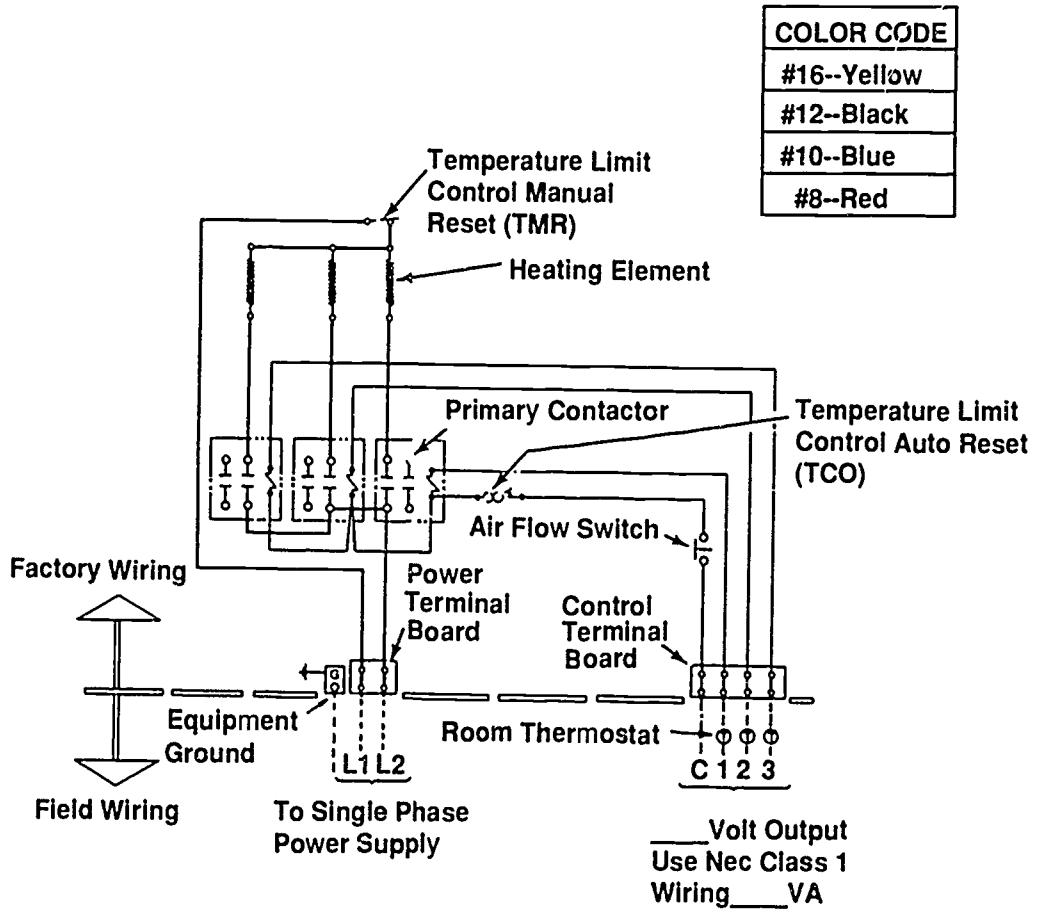

HANDOUT #1

Wiring Diagram #4

The diagram shows a three phase, two stage heater drawing less than 48 amperes total. The system is shown with contactor back-up for protection, power fusing, Class 2 control transformer, and with fan interlock contacts.

Diagram #4

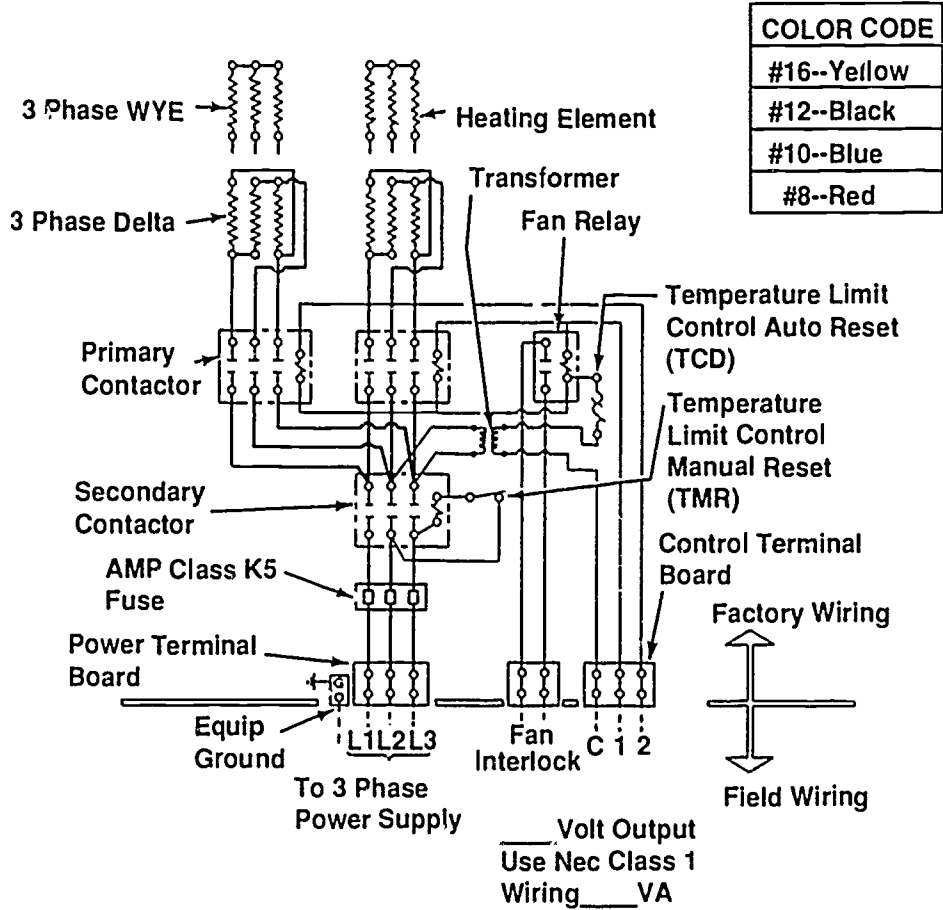

HANDOUT #1

Wiring Diagram #5

The diagram shows a three phase, two stage heater drawing more than 48 amperes total. The system is shown with contactors for back-up protection, power fusing, main power disconnect switch, airflow switch, and Class 2 control transformer for 24 volts.

Diagram #5

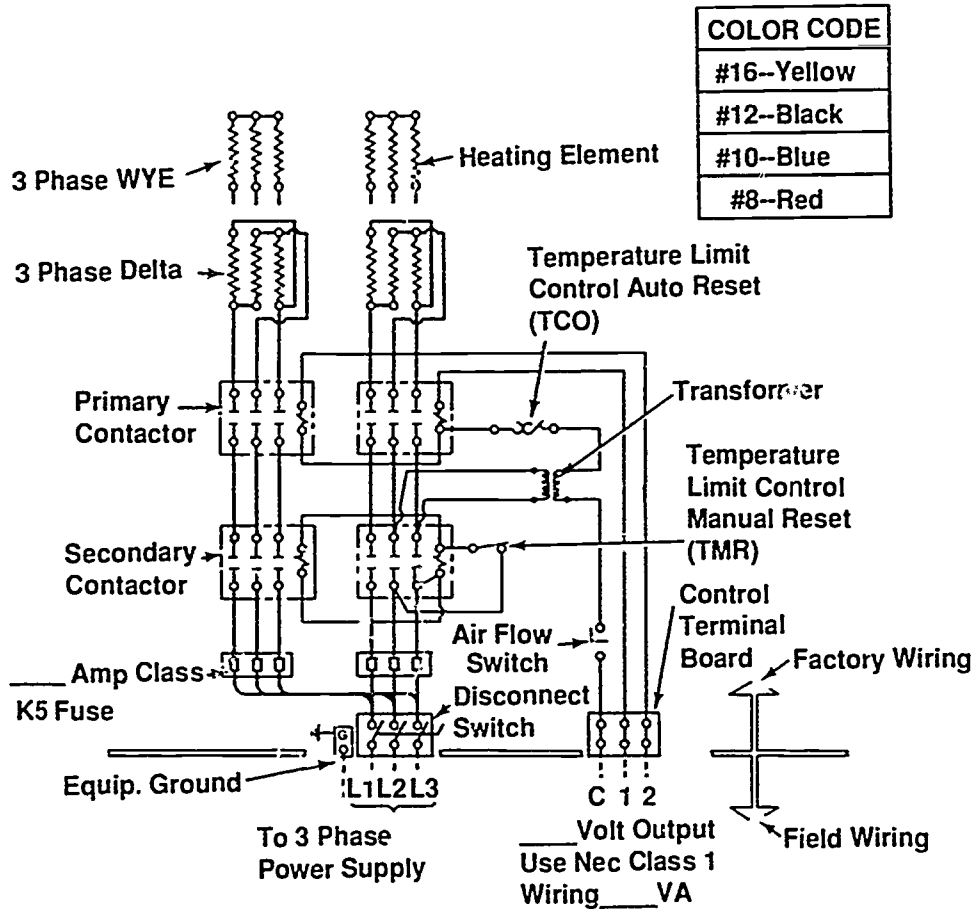

Conclusion

Having typical wiring diagrams to reference is always a big help with electrical installations. Committing the major elements of diagrams to memory is even more beneficial, and the mark of a technician who wants to stay on top of his/her occupation.

**ELECTRICAL HEATING SYSTEMS
UNIT XII**

**JOB SHEET #1 — INSTALL, START, AND CHECK
AN ELECTRICAL HEATING UNIT**

A. Tools and equipment

1. Service technician's tool pouch
2. Ammeter-voltmeter
3. Hammer
4. Aviation snips
5. Electric drill and drill bits
6. Safety glasses

B. Procedure

(NOTE: Read and follow manufacturer's installation instructions.)

1. Check work area for safety and put on safety glasses.
2. Remove electrical heating unit from crating.
3. Place unit in designated location.
4. Adapt and attach unit to duct system.
5. Connect low voltage wiring to low voltage connections.
6. Install thermostat.
7. Connect power supply to load side of safety switch.
8. Connect power supply wiring to supply power terminals on unit.
9. Turn thermostat to "OFF" position.
10. Close safety switch to energize system and check for proper voltage.
11. Start unit by setting thermostat to the "ON" position and "calling" for heat.
12. Check blower section for proper air delivery.
13. Use ammeter to check load on fan motor for tolerance.
14. Use ammeter to check current load of heating elements.
15. Check for proper voltage with all elements on.

JOB SHEET #1

- Have your instructor check your work.
- 16. Turn power off.
- 17. Clean area and put tools away.

577

**ELECTRICAL HEATING SYSTEMS
UNIT XII****JOB SHEET #2 — DISASSEMBLE, INSPECT AND REASSEMBLE
AN ELECTRIC FURNACE****A. Tools and equipment**

1. Service technician's tool pouch
2. Ammeter-Voltmeter
3. Replacement parts as required
4. Safety glasses

B. Procedure

1. Put on safety glasses and check work area.
2. Disconnect power source at the main breaker box and check with a voltmeter to be sure it is off.
3. Remove front panel.
4. Remove blower and motor holding screws.
5. Remove heater unit screws and slide the unit out.
6. Inspect for element damage.
7. Replace damaged parts.
8. Clean and oil blower and motor assembly if needed.
9. Reassemble unit by repeating procedure in reverse.
10. Energize unit and check for proper operation.
11. Make inspection checks of your work.
- Have your instructor check your work.
12. Turn power off.
13. Clean area and put tools away.

**ELECTRICAL HEATING SYSTEMS
UNIT XII**

JOB SHEET #3 — TROUBLESHOOT AN ELECTRIC FURNACE

A. Tools

1. Technician's service tool pouch/box
2. Ohmmeter, voltmeter, ammeter
3. Safety glasses

B. Procedure

1. Put on safety glasses and check work area.
2. Disconnect furnace power source and check with a voltmeter to make sure it is off.
3. Remove furnace panels.
4. Remove cover of control box.
5. Check for voltage at power lugs to make certain power is off.
6. Check for continuity and grounded heating elements.
 - a. Set volt-ohmmeter to measure resistance.
 - b. Remove power wires from elements.
 - c. Measure resistance of heating elements and record:
 - d. #1 _____ ohms #2 _____ ohms #3 _____ ohms.
 - e. Reconnect power wires to elements.
 - f. What would elements read if open? _____ What would elements read if shorted? _____
 - g. Are any elements grounded? _____
7. Check contactor and sequencers for continuity because faulty sequencers are a fairly common problem.
 - a. Set volt-ohmmeter to measure resistance.
 - b. Disconnect low voltage wires from contactor and/or sequencer #1.
 - c. Measure resistance of contactor coil and record. _____
 - d. Measure resistance of sequencer heater and record. _____

JOB SHEET #3

- e. Measure resistance of any other sequencer heater and record:
#2 _____ ohms #3 _____ ohms.
- f. Reconnect low voltage wires to contactor and sequencer.
- g. What would be the resistance of an open coil circuit? _____ ohms; a shorted coil? _____ ohms
- h. What would be the resistance of an open heater circuit in a sequencer? _____ ohms; a shorted heater circuit? _____ ohms
8. Check continuity and grounding of blower power circuit.
9. Check continuity of fan relay coil circuit:
- a. Set volt-ohmmeter to measure resistance.
- b. Disconnect control wires from fan relay.
- c. Measure resistance of fan relay coil and record _____ ohms.
- d. Reconnect control wires to fan relay.
10. Check resistance of primary and secondary windings of low voltage transformer:
- a. Set volt-ohmmeter to measure resistance.
- b. Disconnect secondary leads from transformer.
- c. Measure resistance of secondary windings of transformer and record _____ ohms.
- d. Disconnect primary leads from transformer.
- e. Measure resistance of primary windings of transformer and record _____ ohms.
- f. Measure resistance from each leg of primary winding to ground and record L1 to ground _____ ohms; L2 to ground _____ ohms.
- g. Reconnect secondary and primary leads of transformer.
- h. Is secondary winding of the transformer shorted? _____
Open? _____.
- i. Is primary winding of the transformer shorted? _____
Open? _____ Grounded? _____.

JOB SHEET #3

- j. Have all the circuits in this electric furnace been checked? _____.
- k. Is this furnace safe to energize? _____.
- 10. Replace control box cover and furnace panels.
- 11. Reconnect power source.
- 12. Check and record voltage _____.
- 13. Check and record amp draw _____.
- 14. Calculate Btuh capacity at the recorded voltage and amp draw _____.
- Have your instructor check your work.
- 15. Turn power off.
- 16. Clean area and put tools away.

**ELECTRICAL HEATING SYSTEMS
UNIT XII****JOB SHEET #4 — PERFORM MAINTENANCE ON AN ELECTRIC FURNACE****A. Tools**

1. Service technician's tool pouch
2. Thermometer and scratch awl
3. Shop rag
4. Ammeter-voltmeter
5. Safety glasses

B. Procedure

1. Put on safety glasses and check work area.
2. Open furnace power switch making certain power is OFF.
3. Inspect wiring for possible poor connections.
4. Service blower section.
5. Energize furnace, take fan motor amperage draw and record: _____.
6. De-energize furnace and snap ammeter over wire to power lug to main furnace power.
7. Set thermostat to "heat" and adjust setting to higher than room temperature.
8. Re-energize furnace and record amp draw of heaters as sequencers close heater circuits and record voltage supplied to furnace: _____.
9. Record blower motor and heater amps:
#1_____
#2_____
#3_____
#4_____
10. Compare full load amps with furnace nameplate rating.
11. Check to see if all of the heaters are pulling the proper amperage.

JOB SHEET #4

12. Drive scratch awl into return air plenum, insert thermometer and record return air temperature _____.
13. Select a place in the supply trunk which is out of the "line of sight" of the electric heater elements and drive scratch awl into supply trunk.
14. Record supply air temperature _____.
15. Record temperature rise through furnace _____.
16. Remove thermometer and plug holes.
17. De-energize furnace at disconnect and check with a voltmeter to make sure it is off.
18. Replace control box cover and panel.
19. Re-energize furnace.
20. Reset thermostat to proper setting.
21. Calculate Btuh capacity of the furnace from the recorded voltage and amperage readings _____.
- Have your instructor check your work.
22. Clean area and put tools away.

583

**ELECTRICAL HEATING SYSTEMS
UNIT XII**

PRACTICAL TEST #1

**JOB SHEET #1 — INSTALL, START, AND CHECK AN
ELECTRICAL HEATING UNIT**

Student's name _____ Date _____

Evaluator's name _____ Attempt No. _____

Student instructions: When you are ready to perform this task, ask your instructor to observe the procedure and complete this form. All items listed under "Process Evaluation" must receive a "Yes" for you to receive an overall performance evaluation.

PROCESS EVALUATION

(EVALUATOR NOTE: Place a check mark in the "Yes" or "No" blanks to designate whether or not the student has satisfactorily achieved each step in this procedure. If the student is unable to achieve this competency, have the student review the materials and try again.)

The student:	Yes	No
1. Placed unit and attached duct system.	<input type="checkbox"/>	<input type="checkbox"/>
2. Connected low voltage wiring and installed thermostat.	<input type="checkbox"/>	<input type="checkbox"/>
3. Connected power supply and power supply wiring.	<input type="checkbox"/>	<input type="checkbox"/>
4. Turned thermostat to OFF.	<input type="checkbox"/>	<input type="checkbox"/>
5. Energized system and checked for proper voltage.	<input type="checkbox"/>	<input type="checkbox"/>
6. Turned thermostat to ON, calling for heat.	<input type="checkbox"/>	<input type="checkbox"/>
7. Used ammeter to check fan motor load and current load of heating elements.	<input type="checkbox"/>	<input type="checkbox"/>
8. Checked blower section for proper air delivery.	<input type="checkbox"/>	<input type="checkbox"/>

EVALUATOR'S COMMENTS: _____

JOB SHEET #1 PRACTICAL TEST

PRODUCT EVALUATION

(EVALUATOR NOTE: Rate the student on the following criteria by circling the appropriate numbers. Each item must be rated at least a "3" for mastery to be demonstrated. (See performance evaluation key below.) If the student is unable to demonstrate mastery, student materials should be reviewed and another test procedure must be submitted for evaluation.)

Criteria:

System installation	4	3	2	1
System wiring	4	3	2	1
Load verification	4	3	2	1
System checkout	4	3	2	1

EVALUATOR'S COMMENTS: _____

PERFORMANCE EVALUATION KEY

- 4 — **Skilled** — Can perform job with no additional training.
- 3 — **Moderately skilled** — Has performed job during training program; limited additional training may be required.
- 2 — **Limited skill** — Has performed job during training program; additional training is required to develop skill.
- 1 — **Unskilled** — Is familiar with process, but is unable to perform job.

(EVALUATOR NOTE: If an average score is needed to coincide with a competency profile, total the designated points in "Product Evaluation" and divide by the total number of criteria.)

585

**ELECTRICAL HEATING SYSTEMS
UNIT XII**

PRACTICAL TEST 2

**JOB SHEET #2 — DISASSEMBLE, INSPECT AND REASSEMBLE
AN ELECTRIC FURNACE**

Student's name _____ Date _____

Evaluator's name _____ Attempt No. _____

Student instructions: When you are ready to perform this task, ask your instructor to observe the procedure and complete this form. All items listed under "Process Evaluation" must receive a "Yes" for you to receive an overall performance evaluation.

PROCESS EVALUATION

(EVALUATOR NOTE: Place a check mark in the "Yes" or "No" blanks to designate whether or not the student has satisfactorily achieved each step in this procedure. If the student is unable to achieve this competency, have the student review the materials and try again.)

The student:	Yes	No
1. Disassembled furnace safely.	<input type="checkbox"/>	<input type="checkbox"/>
2. Removed blower and motor assembly.	<input type="checkbox"/>	<input type="checkbox"/>
3. Removed heater unit.	<input type="checkbox"/>	<input type="checkbox"/>
4. Inspected for parts and element damage.	<input type="checkbox"/>	<input type="checkbox"/>
5. Replaced damaged parts.	<input type="checkbox"/>	<input type="checkbox"/>
6. Cleaned and oiled blower and motor assembly as required.	<input type="checkbox"/>	<input type="checkbox"/>
7. Reassembled system properly.	<input type="checkbox"/>	<input type="checkbox"/>
8. Verified system operation.	<input type="checkbox"/>	<input type="checkbox"/>

EVALUATOR'S COMMENTS: _____

JOB SHEET #2 PRACTICAL TEST

PRODUCT EVALUATION

(EVALUATOR NOTE: Rate the student on the following criteria by circling the appropriate numbers. Each item must be rated at least a "3" for mastery to be demonstrated. (See performance evaluation key below.) If the student is unable to demonstrate mastery, student materials should be reviewed and another test procedure must be submitted for evaluation.)

Criteria:

Disassembly	4	3	2	1
Parts removal	4	3	2	1
Parts inspection	4	3	2	1
Reassembly and operation verification	4	3	2	1

EVALUATOR'S COMMENTS: _____

PERFORMANCE EVALUATION KEY

- 4 — **Skilled** — Can perform job with no additional training.
 3 — **Moderately skilled** — Has performed job during training program; limited additional training may be required.
 2 — **Limited skill** — Has performed job during training program; additional training is required to develop skill.
 1 — **Unskilled** — Is familiar with process, but is unable to perform job.

(EVALUATOR NOTE: If an average score is needed to coincide with a competency profile, total the designated points in "Product Evaluation" and divide by the total number of criteria.)

**ELECTRICAL HEATING SYSTEMS
UNIT XII**

PRACTICAL TEST #3

JOB SHEET #3 — TROUBLESHOOT AN ELECTRIC FURNACE

Student's name _____ Date _____

Evaluator's name _____ Attempt No. _____

Student instructions: When you are ready to perform this task, ask your instructor to observe the procedure and complete this form. All items listed under "Process Evaluation" must receive a "Yes" for you to receive an overall performance evaluation.

PROCESS EVALUATION

(EVALUATOR NOTE: Place a check mark in the "Yes" or "No" blanks to designate whether or not the student has satisfactorily achieved each step in this procedure. If the student is unable to achieve this competency, have the student review the materials and try again.)

The student:	Yes	No
1. Checked voltage at power lugs.	<input type="checkbox"/>	<input type="checkbox"/>
2. Checked for continuity and grounded heating elements.	<input type="checkbox"/>	<input type="checkbox"/>
3. Checked for sequencer and contactor continuity.	<input type="checkbox"/>	<input type="checkbox"/>
4. Checked for continuity and grounding of blower power circuit.	<input type="checkbox"/>	<input type="checkbox"/>
5. Checked continuity of fan relay coil circuit.	<input type="checkbox"/>	<input type="checkbox"/>
6. Checked resistance of primary and secondary windings in low voltage transformer.	<input type="checkbox"/>	<input type="checkbox"/>
7. Verified check of all circuits.	<input type="checkbox"/>	<input type="checkbox"/>
8. Checked voltage, amp draw, and calculated Btuh.	<input type="checkbox"/>	<input type="checkbox"/>

EVALUATOR'S COMMENTS: _____

JOB SHEET #3 PRACTICAL TEST

PRODUCT EVALUATION

(EVALUATOR NOTE: Rate the student on the following criteria by circling the appropriate numbers. Each item must be rated at least a "3" for mastery to be demonstrated. (See performance evaluation key below.) If the student is unable to demonstrate mastery, student materials should be reviewed and another test procedure must be submitted for evaluation.)

Criteria: _____

Heating element checkout	4	3	2	1
Contact and sequencer checkout	4	3	2	1
Blower and fan relay checkout	4	3	2	1
System voltage, amp draw, and Btuh capacity	4	3	2	1

EVALUATOR'S COMMENTS: _____

PERFORMANCE EVALUATION KEY
4 — Skilled — Can perform job with no additional training.
3 — Moderately skilled — Has performed job during training program; limited additional training may be required.
2 — Limited skill — Has performed job during training program; additional training is required to develop skill.
1 — Unskilled — Is familiar with process, but is unable to perform job.

(EVALUATOR NOTE: If an average score is needed to coincide with a competency profile, total the designated points in "Product Evaluation" and divide by the total number of criteria.)

**ELECTRICAL HEATING SYSTEMS
UNIT XII**

PRACTICAL TEST #4

JOB SHEET #4 — PERFORM MAINTENANCE ON AN ELECTRIC FURNACE

Student's name _____ Date _____

Evaluator's name _____ Attempt No. _____

Student instructions: When you are ready to perform this task, ask your instructor to observe the procedure and complete this form. All items listed under "Process Evaluation" must receive a "Yes" for you to receive an overall performance evaluation.

PROCESS EVALUATION

(EVALUATOR NOTE: Place a check mark in the "Yes" or "No" blanks to designate whether or not the student has satisfactorily achieved each step in this procedure. If the student is unable to achieve this competency, have the student review the materials and try again.)

The student:	Yes	No
1. Prepared furnace for safe inspection.	<input type="checkbox"/>	<input type="checkbox"/>
2. Inspected wiring.	<input type="checkbox"/>	<input type="checkbox"/>
3. Serviced blower section.	<input type="checkbox"/>	<input type="checkbox"/>
4. Checked heater circuits.	<input type="checkbox"/>	<input type="checkbox"/>
5. Used scratch awl to prepare supply and return plenums.	<input type="checkbox"/>	<input type="checkbox"/>
6. Measured return and supply air temperature to determine temperature rise.	<input type="checkbox"/>	<input type="checkbox"/>
7. Replaced all panels and covers.	<input type="checkbox"/>	<input type="checkbox"/>
8. Verified proper system operation.	<input type="checkbox"/>	<input type="checkbox"/>

EVALUATOR'S COMMENTS: _____

JOB SHEET #4 PRACTICAL TEST

PRODUCT EVALUATION

(EVALUATOR NOTE: Rate the student on the following criteria by circling the appropriate numbers. Each item must be rated at least a "3" for mastery to be demonstrated. (See performance evaluation key below.) If the student is unable to demonstrate mastery, student materials should be reviewed and another test procedure must be submitted for evaluation.)

Criteria: _____

Furnace preparation	4	3	2	1
Electrical checkout	4	3	2	1
Temperature rise calculation	4	3	2	1
System operation verification	4	3	2	1

EVALUATOR'S COMMENTS: _____

PERFORMANCE EVALUATION KEY
4 — Skilled — Can perform job with no additional training.
3 — Moderately skilled — Has performed job during training program; limited additional training may be required.
2 — Limited skill — Has performed job during training program; additional training is required to develop skill.
1 — Unskilled — Is familiar with process, but is unable to perform job.

(EVALUATOR NOTE: If an average score is needed to coincide with a competency profile, total the designated points in "Product Evaluation" and divide by the total number of criteria.)

ELECTRICAL HEATING SYSTEMS UNIT XII

TEST

NAME _____

SCORE _____

1. Match the terms on the right with their correct definitions.

- | | | | |
|-------|---|-----|--------------------|
| _____ | a. An alloy used extensively as a heat source for electric resistance heat | 1. | Line voltage |
| _____ | b. A relay capable of opening and closing circuits of high amperage | 2. | SCR |
| _____ | c. The power, such as 240V, supplied to a heater | 3. | Sequencer |
| _____ | d. A device to open or close a circuit by allowing time to elapse after heater is energized or de-energized | 4. | Sail switch |
| _____ | e. A relay that operates a furnace blower, frequently incorporated with the first stage heating sequencer of an electric furnace | 5. | Contactor |
| _____ | f. Heavy duty fittings for connecting power wires to a high amperage appliance such as in electric furnace | 6. | Staging |
| _____ | g. A safety device that opens the circuit when there is excessive temperature rise | 7. | Air sensing switch |
| _____ | h. A backup safety device designed to melt at a specified temperature higher than the regular limit switch, thereby opening the circuit | 8. | Nichrome |
| _____ | i. A switch that senses the air pressure in a duct and allows the heaters to be energized only when air is moving over the elements | 9. | High limit switch |
| _____ | j. A switching device with a "sail" mounted to a moveable arm in the duct allowing heater operation when there is air flowing | 10. | Fusible link |

TEST

- _____k. Solid state device incorporated into electric duct heaters to control the heat output by varying the time the heater is "on" by using electronic proportioning
- _____l. A control strategy for bringing heating elements on as they are needed in relation to temperature drop
- _____m. The point, expressed in °F, where the heat pump capacity is equal to or balanced with the heat loss of the structure
- _____n. A device, usually solid state, used to open or close a circuit within a specific time period after the circuit has been energized or de-energized

11. Power lugs
12. Fan relay
13. Time delay relay
14. Balance point

2. Identify the types of electrical heating systems shown in the following illustrations.

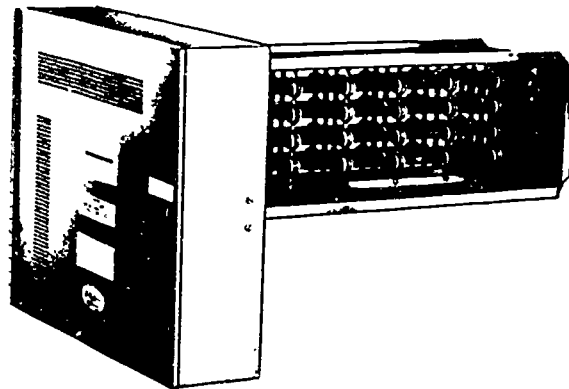

a. _____

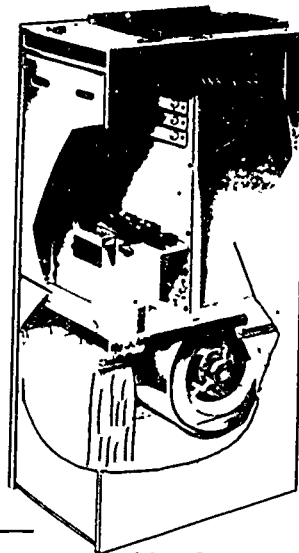

b. _____

TEST

3. Differentiate between duct heaters and electric furnaces by placing a "D" next to items that pertain to duct heaters and an "E" next to items that pertain to electric furnaces.
- _____ a. Placed in a heating duct with remote blower
 - _____ b. Consists of self-contained complete system with blower assembly, electric heating elements, and line voltage and low voltage controls that vary with manufacturer
 - _____ c. Installed four feet downstream from cooling coil unless approved for use as integral part of equipment
4. Complete a list of components of electric heating equipment†
- a. Blower assembly
 - b. Heater element assembly
 - 1) _____
 - 2) _____
 - 3) _____
 - c. Electric heat circuits and controls
 - 1) Low voltage fan circuit
 - a) _____
 - b) _____
 - c) _____
 - 2) Line voltage fan circuit
 - a) _____
 - b) _____
 - c) _____
 - 3) Low voltage heater circuits
 - a) _____
 - b) _____
 - c) _____
 - d) _____

TEST

- 4) Line voltage heater circuit
- a) _____
- b) _____
- c) _____
- d) _____

5. Select true statements concerning causes of common failures of electric heating equipment components. Place an "X" beside each true statement.

(NOTE: For a statement to be true, all parts of the statement must be true.)

- _____ a. Heating element circuit open
- 1) Melted fusible link
- 2) Nichrome wire burned in two because of:
- a) Dirty filters
- b) Undersized ductwork or too many outlets closed
- c) Dirty cooling coil
- d) Broken insulator
- _____ b. Burned out sequencer
- _____ c. Stuck limit switch
- _____ d. Burned out transformer
- _____ e. Loose connections

6. Match staging methods with their operations.

- | | |
|--|------------------------------|
| _____ a. First stage turns on some elements until the temperature in a space begins to drop, and the second stage turns on remaining heating elements | 1. SCR |
| _____ b. Wired into the control circuit to part of the heating elements which are kept off until the temperature drops below a balance point in a heat pump system | 2. Two-stage wall thermostat |
| _____ c. Controls heat by varying the time the elements are on | 3. Outdoor thermostat |

TEST

7. Complete statements concerning installing duct heaters. Circle the material that best completes each statement.
- a. Duct heaters should be installed at least (four) (two) feet downstream from an air handler and (four) (two) feet downstream from heat pumps or air conditioners.
 - b. When a canvas duct is used to dampen equipment vibration, the duct heater should be installed at least (four) (two) feet downstream from the canvas.
 - c. When a heater cannot be placed at least 4 feet downstream from canvas duct, the canvas should be (replaced) (covered) with metal.
 - d. Duct heaters should be installed (two) (four) feet on either side of an elbow.
 - e. Turning vanes installed in the elbow will reduce (pressure losses) (friction) and insure that air velocity is uniformly distributed over the cross section of the duct.
 - f. The heater should be installed at least (four) (two) feet from the transition section for a change in duct size.
 - g. If splitters are required in the transition section, they should be installed (downstream) (upstream) of the heater to insure uniform air flow over the entire face of the heater.
8. Solve problems concerning installing heaters smaller or larger than ductwork. Select the best solution to each of the following.
- a. You discover the heater you are installing is smaller than the duct it must go into. Can you use the heater? _____.
 - 1) Definitely not.
 - 2) Yes, because the open area can be filled with wire mesh or expanded metal.
 - 3) Yes, because the duct can be narrowed.
 - b. You discover the heater you are installing is larger than the ductwork. Can you use the heater?
 - 1) Definitely not.
 - 2) Yes, because the heater can be slightly turned.
 - 3) Yes, because the duct can be enlarged with a sheet metal transition.

TEST

9. Solve problems concerning installing slip-in heaters. Select the best solution to each of the following.
- a. You have been sent to install a slip-in heater in a duct. What are the first two things you should do? _____.
- 1) Carefully measure the area where the heater is supposed to go and then cut the opening.
 - 2) Check the heater and write down all plate numbers.
 - 3) Call the office and verify that you have the right heater.
- b. You have the slip-in heater installed, but you wonder if the duct can support the weight. You decide to _____.
- 1) Let it ride.
 - 2) Use hangar straps to assure a safe installation.
 - 3) Add extra sheet metal screws.
10. Solve problems concerning installing flange-type heaters. Select the best solution to each of the following.
- a. You have installed a flange-type heater and want to properly secure it. What do you do? _____.
- 1) Use hangar straps just to be sure.
 - 2) Bolt the unit in place.
 - 3) Use heavy sheet metal screws to secure the unit.
- b. You notice that the duct flange seems awfully thin. Do you go ahead and install the heater? _____.
- 1) Yes, if the duct flange can be doubled to add strength.
 - 2) No, the design will have to be changed.
 - 3) Yes, if the heater can be supported by a block.
11. Select true statements concerning general recommendations for installing duct heaters. Place an "X" beside each statement that is true.
- (NOTE: For a statement to be true, all parts of the statement must be true.)
- _____ a. Heaters may be installed in the sides of either horizontal or vertical duct, on the top or bottom of horizontal duct.

TEST

- _____b. Heaters should be installed safe distances from other equipment and according to the rules of two:
- 1) Two feet from a heat pump or central air conditioner .
 - 2) Two feet downstream from an air handler
 - 3) Two feet upstream from a humidifier
 - 4) Two feet away from a canvas duct connector or a transition change in duct size
- _____c. At an elbow or turn, a heater should be installed at least four feet away on either side.
12. Solve problems concerning gathering information for system sizing. Select the best solution to each of the following.
- a. The output of resistance heating is expressed in what? _____.
 - 1) Amperage
 - 2) Current
 - 3) Watts
 - b. What percentage of electrical power converts directly into heat? _____.
 - 1) 90 percent.
 - 2) 95 percent.
 - 3) 100 percent.
 - c. How would you express a reading of 20,000 watts in kilowatts? _____.
 - 1) 2 KW
 - 2) 20 KW
 - 3) 200 KW
 - d. If you had a return air supply of 70°F and a supply air temperature of 110°F, what would the temperature rise be? _____.
 - 1) 35°
 - 2) 40°
 - 3) 45°
13. Use formulas for sizing electrical heating systems. Provide the proper requirements for the following situations.
- a. You know the CFM requirement of a system is 2,000 and that the system has a TR of 45°. Determine the KW requirement of the system by using the following formula:

$$KW = \frac{CFM \times TR}{3150}$$
 Answer _____

TEST

- b. You know the KW requirement of a system is 15 and that the CFM is 1,200. Determine the temperature rise requirement of the system by using the following formula:

$$TR = \frac{KW \times 3150}{CFM}$$

Answer _____

- c. You know the KW requirement of a system is 15 and that the temperature rise is 35°. Determine the CFM requirement of the system using the following formula:

$$CFM = \frac{KW \times 3150}{TR}$$

Answer _____

(NOTE: If the following activities have not been accomplished prior to the test, ask your instructor when they should be completed.)

14. Demonstrate the ability to:
- Install, start, and check an electrical heating unit. (Job Sheet #1)
 - Disassemble, inspect, and reassemble an electric furnace. (Job Sheet #2)
 - Troubleshoot an electric furnace. (Job Sheet #3)
 - Perform maintenance on an electric furnace. (Job Sheet #4)

**ELECTRICAL HEATING SYSTEMS
UNIT XII**

ANSWERS TO TEST

1. a. 8 e. 12 i. 7 m. 14
 b. 5 f. 11 j. 4 n. 13
 c. 1 g. 9 k. 2
 d. 3 h. 10 l. 6
2. a. Duct heater
 b. Electric furnace
3. a. D
 b. E
 c. D
4. b. 1) Nichrome wire coils installed through insulators in path of air stream
 2) Fusible link in line voltage circuit of heater coil exposed to radiant heat of heater element
 3) High temperature limit controls vary with manufacturer
- c. 1) a) Transformer
 b) Thermostat
 c) Fan relay coil or sequencer heater
- 2) a) Blower motor
 b) Fan relay contacts or sequencer contacts
 c) Fuse or breaker
- 3) a) Transformer
 b) Thermostat
 c) Contactor or sequencer coil
 d) High limit switch
- 4) a) Heater element
 b) Fusible link
 c) Contactor contacts or sequencer contacts
 d) Fuse or breaker
5. a, b, c, d, e
6. a. 2
 b. 3
 c. 1

ANSWERS TO TEST

7. a. Four, four
b. Four
c. Replaced
d. Two
e. Pressure losses
f. Four
g. Upstream
8. a. 2)
b. 3)
9. a. 1)
b. 2)
10. a. 2)
b. 1)
11. None of the statements are true
12. a. 3)
b. 3)
c. 2)
d. 2)
13. a. 28.5 KW
b. 39.3°
c. 1,350 CFM
14. a. Evaluated according to criteria in Practical Test #1
b. Evaluated according to criteria in Practical Test #2
c. Evaluated according to criteria in Practical Test #3
d. Evaluated according to criteria in Practical Test #4



COOLING SYSTEMS UNIT XIII

UNIT OBJECTIVE

After completion of this unit, the student should be able to troubleshoot and perform maintenance on an air conditioner. These competencies will be demonstrated by completing the assignment and job sheets, and by scoring a minimum of 85 percent on the unit test.

SPECIFIC OBJECTIVES

After completion of this unit, the student should be able to:

1. Match terms related to cooling systems with their correct definitions.
2. Complete a list of basic mechanical components of a cooling system.
3. Complete a list of additional components found on some residential and light commercial units.
4. Match electrical components with their functions.
5. Arrange in order the steps in a cooling cycle.
6. Select true statements concerning indoor fan operation.
7. Match compressor motor failures with ways to detect them.
8. Match compressor mechanical failures with ways to detect them.
9. Solve problems concerning causes of compressor failures.
10. Match problems in condensing units with their probable causes.
11. Select true statements concerning functions of low side section components in an air conditioner.
12. Match component problems of low side sections with their probable causes.
13. Arrange in order the steps in using a charging table.
14. Complete statements concerning guidelines for charging a system.

OBJECTIVE SHEET

15. Select true statements concerning the scroll compressor.
16. Complete statements concerning evaporative coolers.
17. Select true statements concerning evaporative cooling applications.
18. Solve problems concerning refrigerant recovery and recycling.
19. Trace the cooling circuit on a single phase package heat/cool unit. (Assignment Sheet #1)
20. Trace the cooling circuit on a 7½ ton three phase rooftop unit. (Assignment Sheet #2)
21. Demonstrate the ability to:
 - a. Troubleshoot an air conditioning condenser section on a "no cooling" complaint. (Job Sheet #1)
 - b. Use a charging table to check the charge in a capillary cooling system. (Job Sheet #2)
 - c. Perform maintenance on an air conditioner. (Job Sheet #3)

**COOLING SYSTEMS
UNIT XIII****SUGGESTED ACTIVITIES**

- A. Obtain additional materials and/or invite resource people to class to supplement/reinforce information provided in this unit of instruction.

(NOTE: This activity should be completed prior to the teaching of this unit.)

- B. Make transparencies from the transparency masters included with this unit.
- C. Provide students with objective sheet.
- D. Discuss unit and specific objectives.
- E. Provide students with information and assignment sheets.
- F. Discuss information and assignment sheets.

(NOTE: Use the transparencies to enhance the information as needed.)

- G. Provide students with job sheets.
- H. Discuss and demonstrate the procedures outlined in the job sheets.
- I. Integrate the following activities throughout the teaching of this unit:
1. Invite a service technician from industry to talk with students.
 2. Invite a factory representative to discuss innovations in cooling system design.
 3. Invite utility representative to discuss benefits of energy saving high efficiency cooling systems.
 4. Meet individually with students to evaluate their progress through this unit of instruction, and indicate to them possible areas for improvement.
- J. Give test.
- K. Evaluate test.
- L. Reteach if necessary.

SUGGESTED ACTIVITIES

REFERENCES USED IN DEVELOPING THIS UNIT

- A. Air Conditioning and Refrigeration Institute. *Refrigeration and Air Conditioning, Second Edition*. Englewood Cliffs, NJ 07623: Prentice-Hall, Inc., 1987.
- B. Althouse, Andrew D., and Carl H. Turnquist and Alfred F. Bracciano. *Modern Refrigeration and Air Conditioning*. South Holland, IL: The Goodheart-Wilcox Company, Inc., 1988.
- C. Copeland Corporation Training Materials. Sidney, OH 45362: The Copeland Corporation, 1988.
- D. Eckes, William, and Dan Fulkerson. *Air Conditioning and Refrigeration, Book Four*. Stillwater, OK 74074: Mid-America Vocational Curriculum Consortium, Inc., 1981.
- E. Lang, Paul V. *Principles of Air Conditioning*. Albany, NY 12205: Delmar Publishers, 1987.
- F. *Air Conditioning Service Manual*. Lavergne, TN 37086: Heil-Quaker Corporation, 1985.
- G. *Air Conditioning Installation and Service*. Lavergne, TN 37086: Heil-Quaker Corporation, 1988.
- H. "Evaporative Cooler Use and Care Manual." Phoenix, AZ 85034: ArvinAir, Inc., no date.

**COOLING SYSTEMS
UNIT XIII****INFORMATION SHEET****I. Terms and definitions**

- A. **Schrader valve** — A gauge port made like an automobile tire valve
- B. **Crankcase heater** — A low wattage device that boils refrigerant out of the compressor crankcase

(NOTE: The heater may be external or internal or the compressor motor windings may be used as a source of low current flow during the off cycle.)
- C. **Lockout relay** — A normally closed relay used to open a protective circuit while the relay coil is energized
- D. **Start kit** — A starting relay and capacitor added to a compressor circuit
- E. **Suction line accumulator** — A tank installed in the suction line to hold liquid refrigerant to guard against flood back to the compressor
- F. **Receiver** — A tank in a refrigeration system for storing liquid refrigerant
- G. **Refrigerant lines** — Lines which connect a condensing unit to a cooling coil
- H. **Liquid line solenoid valve** — Closes the liquid line during the "off" cycle
- I. **Low side** — The low pressure part of the refrigeration system, namely the evaporator coil and suction line
- J. **High side** — The high pressure part of the refrigeration system, namely the discharge line, condenser coil, and liquid line
- K. **SEER** — Seasonal energy efficiency ratio
- L. **PTCR (positive temperature coefficient resistor)** — A solid state start assist device to give the compressor additional starting torque
- M. **Evaporative cooling** — A cooling process that passes air across a wetted pad or water spray
- N. **Charging tables** — Graphs or tables listing proper operating pressures at various operating conditions
- O. **Scroll compressor** — A compressor that has no pistons and compresses gas by use of a stationary scroll (spiral) and an identical scroll that orbits the stationary one
- P. **Variable speed compressor** — A compressor where RPM can be adjusted to modify the refrigerant pumping capacity

INFORMATION SHEET

- Q. **Refrigerant reclaimner** — A device used to remove old refrigerant from a system, clean it, and prepare it for re-use or sometimes a unit to simply remove refrigerant for proper disposal

II. Basic components of a cooling system and their functions (Transparency 1)

- A. **Compressor** — Compresses the low pressure refrigerant gas into a high pressure gas
- B. **Discharge line** — Carries high pressure gas to the condenser
- C. **Condenser** — Where the refrigerant condenses into a liquid giving up heat
- D. **Metering device** — Meters the flow of refrigerant into the evaporator and may be:
1. Fixed orifice type, capillary or piston
 2. Thermostatic expansion valve, sometimes a distributor to supply refrigerant to different parts of the evaporator
- E. **Evaporator** — Where the liquid refrigerant evaporates as it absorbs heat
- F. **Suction line** — Carries the low pressure suction gas to the suction side of the compressor

III. Additional components found on some residential and light commercial units

- A. **Suction line accumulator** — A tank in the suction line to help prevent liquid from entering the compressor
- B. **Receiver** — A tank in the "high side" of the refrigeration system for storing liquid refrige. nt

(NOTE: A receiver is not usually found on a unit with a fixed orifice metering device.)

- C. **Liquid line drier** — Device to capture moisture and neutralize acid
- D. **Suction line drier** — Device to capture moisture and neutralize acid

(NOTE: A suction line drier is usually installed after a compressor failure to aid in cleaning the system)

IV. Electrical components and their functions

- A. **Thermostat and sub-base** — Controls unit operation; usually 24 volt, wall mounted
- B. **Transformer** — Steps the line voltage down to 24 volts for control circuit purposes

INFORMATION SHEET

- C. Contactor — A heavy duty relay that closes and opens the line voltage circuit to the compressor
- D. High pressure switch — Monitors the head pressure and stops compressor operation if head pressure is excessive
- (NOTE: Some compressors have an internal pressure relief valve (IPR) and do not require a high pressure switch.)
- E. Low pressure switch — Monitors the suction pressure and stops compressor operation should suction pressure drop too low (optional)
- F. Crankcase heater — A low wattage heater in contact with the sump of the compressor adding heat during the "off cycle" to prevent liquid migration to the compressor (optional)
- (NOTE: The crankcase may be the PTCR type which provides heat only when required.)
- G. Start kit — A potential relay, start capacitor, and necessary wiring which adds more starting torque to the compressor (optional)
- H. PTCR (positive temperature coefficient resistor) — Adds some starting torque to the compressor, but not as much as the start capacitor, and sometimes referred to as a "start assist" device (optional)
- I. Condenser fan motor — Used to move air over the condenser and may be two speed on some units and require a fan speed control switch
- J. Fan speed control — Device to allow two speed condenser fan motor to operate on low speed at lower ambient temperature
1. Residential switches to high speed usually around 86°F ambient
 2. Light commercial may operate in the same manner or vary the RPM of the fan motor since it may be operating at lower ambient temperatures than residential
- K. Overload protector — An electrical switching device to shut down compressor operation if the motor draws too much current
- (NOTE: The overload protector may be external or internal to the compressor.)
- L. Lockout relay — A normally closed relay used to open a protective circuit while the relay coil is energized, requiring the coil circuit to be de-energized before unit operation will start again (optional)
- M. Run capacitor — Electrical device used in the running circuit of a single phase permanent split capacitor motor
- N. Evaporator blower motor — Used to move air over the evaporator; located in the furnace or indoor section

INFORMATION SHEET

- O. Liquid line solenoid valve — Electrically operated valve to close the liquid line during the "off cycle", usually found on light commercial applications (optional)

V. Steps in a cooling cycle

- A. The system thermostat, responding to room temperature and heat from the cooling anticipator, closes a switch to "call for cooling."
- B. The indoor fan relay coil is energized, closing a set of contacts which complete the line voltage circuit to the evaporator blower motor for cooling speed.
- C. At the same time, the contactor coil is also energized from the thermostat, closing the line voltage circuit to the compressor and condenser fan motor.
- D. When temperature in the conditioned spaced is lowered to set point, the thermostat is "satisfied" and opens the control circuits to complete the cycle.

VI. Indoor fan operation

- A. When the thermostat is set to "auto", the indoor fan will cycle with the condensing unit.
- B. When set to "on" or "cont" on the thermostat, the indoor fan will run continuously regardless of condensing unit operation.
- C. When set for continuous operation with a multi-speed motor, the indoor fan will run at cooling speed.
- D. Many commercial structures use continuous fan operation during hours of occupancy.

VII. Compressor motor failures and ways to detect them

(CAUTION: Open the system disconnect and then remove ALL leads from the compressor terminals before checking motor windings with an ohmmeter.)

- A. Open windings:
 - 1. Open windings can be detected by connecting an ohmmeter to the motor terminals and reading infinite resistance.
 - 2. If equipped with an internal line voltage overload, a hot compressor may show "open" at the common terminal, but show resistance from the start to run terminals.
 - 3. Do not condemn a compressor with an internal overload until the compressor cools down and is checked again.
 - 4. Three phase motors have the same ohm readings between terminals although there may be minor variances.

INFORMATION SHEET**B. Shorted windings:**

1. Shorted windings can be detected by connecting an ohmmeter to the compressor motor terminals and looking for a zero reading or near zero resistance of the motor windings.
2. A perfectly good winding will have a low resistance, so care must be taken with an ohmmeter check.

C. Grounded windings:

1. Grounded windings can be detected by connecting an ohmmeter to ground and checking each motor terminal; any reading means the winding is grounded.
2. The copper tubing at the compressor is a good ground point to use when checking for grounded windings from the motor terminals.

VIII. Compressor mechanical failures and ways to detect them

- A. A tight compressor can be detected by checking current draw and reading locked rotor amps during a stalled condition.
1. It may be necessary to install a "start kit" if the unit is not equipped with one.
 2. Sometimes the compressor may be "bumped" with a start capacitor to get it started initially and then it may run properly.
- B. A broken motor shaft can be detected by reading the same pressure on both refrigerant gauges while compressor is running (motor may "coast" at shutdown).
- C. Leaking valves or head gasket can be detected by less than normal difference between head pressure and suction pressure.
1. Feeling the suction line heat up near the compressor immediately after shut down is another indicator on piston compressors.
 2. You may hear the gas leaking by the valves in the compressor.
 3. A sealed compressor will require replacement.
 4. A semi-hermetic compressor may have valve plates and gaskets replaced in the field.
 5. System pump down may aid in detecting leaking valves.

INFORMATION SHEET

- D. A locked rotor — Can be determined if the compressor still won't start after all efforts have failed.
1. Be sure to check voltage during locked rotor conditions.
 2. Be sure voltage is not below the minimum specified by the manufacturer.
 3. Check for locked rotor amps.

IX. Causes of compressor failures**A. Mechanical failures**

1. Liquid slugging — Result of trying to compress liquid in the cylinders (may be oil or refrigerant)
 - a) Primary cause is refrigerant migration into the oil during the "off" cycle
 - b) Lowering of crankcase pressure on start up causes an explosion carrying quantities of refrigerant and oil into the cylinders
2. Liquid washout — Result of refrigerant washing oil off wearing surfaces
 - a) Possibly caused by saturated refrigerant being returned during the running cycle, but "off" cycle migration is more likely the cause
 - b) Slugging is really just an extreme case of migration
3. Liquid dilution — A result of liquid refrigerant being returned during the "running" cycle, cooling the oil, and becoming so diluted it cannot lubricate properly
4. High discharge temperatures — Result of temperatures in the compressor head becoming so hot the oil loses its ability to lubricate, caused by:
 - a) High compression ratios
 - b) Inadequate compressor cooling
5. Lack of lubrication — Lack of sufficient oil in the crankcase and may be caused by:
 - a) Improper piping
 - b) Loss of charge
 - c) Short cycling
 - d) Low load conditions

INFORMATION SHEET

B. Motor failures

1. General burn — Entire windings are overheated or burned, may be a result of voltage problems, inadequate motor cooling, or unknowns
2. Start winding burn — Start winding burned caused by excessive current flow through it due to a failure of starting components, miswiring or overloading the motor
3. Spot burn — A short between windings, between wires, within a winding or to ground. Damage is confined to a small area and reason unknown
4. Leads shorted — Terminals grounded or leads abraded
5. Single phase burn — Two phases of a three phase motor are overheated or burned, a result of insufficient current through one phase, overloading the other two

X. Problems in condensing units and possible causes

A. Refrigerant leaks

1. Loose mechanical fittings
2. Improper sweat joints
3. Nail hole in refrigerant line somewhere in building

B. Condenser fan motor

1. Worn or seized bearings due to lack of lubrication
2. Open motor windings
3. Grounded motor windings
4. Fan blade out of balance
5. Fan blade not positioned properly
6. Capacitor failure may cause motor to overheat and motor still be okay

C. Start capacitor or potential relay

1. Capacitor terminal burned off
2. Capacitor open
3. Capacitor shorted
4. Relay contacts stuck closed

INFORMATION SHEET

5. Relay contacts won't make
 6. Relay coil open
- D. Run capacitor
1. Open
 2. Shorted
 3. Grounded
 4. Changed capacitance
- E. Contactor
- (CAUTION: Some contactors are single pole, which leaves one leg energized when the system is cycled off, so be careful when servicing such a unit.)**
1. Burned points make poor contact
 2. Points stuck together from arcing
 3. Sticking carriage
 4. Open holding coil
 5. Shorted holding coil
 6. Insects between contactors
- F. Crankcase heater
1. Open
 2. Shorted
- G. Condenser coil
1. Bent coil fins should be combed out
(NOTE: Roof mounted units may be damaged by gravel from some types of roofs.)
 2. Corrosion of metals due to chemical reaction
(NOTE: Pets should be kept away from coils)

INFORMATION SHEET

XI. Functions of low side section components in an air conditioner

A. Blower section

1. Moves air from occupied space through the filter and cooling coil.
2. Returns conditioned air to occupied space.

B. Cooling coil

1. Removes heat and moisture from the air passing through it.
2. When installed in an upflow or counterflow furnace, the cooling coil must be shaped to allow condensed moisture to cling to the fins and drip downward into a condensate drain pan.

(NOTE: This is called an "A" coil.)

3. When installed in a horizontal furnace, the cooling coil is shaped to allow condensed moisture to drip downward perpendicular to the air flow through the coil.
4. An auxiliary drain pan should be installed below the primary drain pan and have its own drain line on horizontal applications.

(NOTE: This is called a horizontal or slab coil.)

C. Condensate pan — Catches condensed water which drips off the cooling coil

D. Condensate drain fitting

1. A factory installed short tube soldered into the condensate pan, usually $\frac{3}{4}$ " I.D. copper for the purpose of connecting the drain pan to a field installed drain line.

(CAUTION: Never reduce the condensate line pipe size.)

2. A trap or anti-siphoning device should be used if the drain is on the suction side of the indoor blower.

E. Metering devices

1. Capillary tube

- a. Meters refrigerant to the cooling coil by restricting its flow due to its length and small diameter.
- b. Permits manufacture of lower cost cooling equipment due to its lower cost and simplicity.

INFORMATION SHEET

2. Thermostatic expansion valve
 - a. Meters refrigerant to the cooling coil by restricting its flow by a continuous throttling action which is controlled by the super heat setting of the valve.
 - b. Permits reliable operation of the cooling coil over a wider temperature range than is practical with other common types of metering devices.
 - c. May use a distributor to feed the evaporator at more than one point.
3. Piston type
 - a. Fixed orifice meters refrigerant to evaporator.
 - b. Capacity changed easily by changing piston.
 - c. Can allow full flow in opposite direction making them popular for use in heat pumps.

XII. Component problems of low side sections and their possible causes

- A. Frozen coil
 1. Insufficient air flow
 2. Dirty filter
 3. Dirty coil
 4. Dirty blower wheel
 5. Undersized ductwork
 6. Low refrigerant charge
- B. Refrigerant leaks at refrigerant line fittings
 1. Galled threads
 2. Compression ferrule on backwards
 3. Incomplete make up of connection

(NOTE: A few drops of compressor oil on a refrigerant line fitting will assure a complete run up of the fitting nut.)

INFORMATION SHEET

- C. Leak in evaporator coil or return bends
 - 1. Vibration
 - 2. Corrosion
- D. Expansion valve
 - 1. Out of adjustment or tolerance
 - 2. Ruptured power element
- E. Coil flooded with oil
 - 1. Untrapped refrigerant lines
 - 2. Result of too many compressor changes (will require you to measure and remove excess oil)

XIII. Steps in using a charging table (Transparency 2)

- A. Attach a refrigeration thermometer to the system's suction line where it enters the condensing unit

(NOTE: Some units have a "well" for the thermometer to fit into for a better reading.)
- B. Attach a suction gauge to the suction line port at the condensing unit.
- C. Record suction line pressure, ambient temperature, and suction line temperature.
- D. Suction line temperature reading should be within 3°F of table reading.

Example: At 90°F outdoor temperature and 68 PSIG suction pressure, the system will be correctly charged if the recorded suction line temperature is between 54° and 60°F; a reading above 60°F would indicate an undercharge and a reading below 54°F would indicate an overcharge.

(NOTE: As little as half an ounce variation in refrigerant charge can significantly change the performance of a system. Transparencies 3 and 4).

XIV. Guidelines for charging a system

- A. Using a "rule of thumb" or a "typical charging table" is one way to charge a system, but a better way is to work directly from the manufacturer's specifications. (Transparency 3)
- B. In undercharging or overcharging, the desired capacity and efficiency of the unit drops off rapidly.

INFORMATION SHEET

- C. Maximum capacity is achieved at 100% charge as reflected on a net coil capacity versus percent refrigeration chart. (Transparency 4)
- D. Maximum efficiency is also achieved at 100% charge as reflected on an EER rating versus percent refrigeration chart. (Transparency 5)
- E. Most manufacturers recommend weighing the charge to make sure it is within half an ounce of the prescribed amount.

XV. The scroll compressor (Transparency 6)

(NOTE. The scroll compressor was introduced into residential and light commercial markets in late 1980s.)

- A. Compresses gas by interaction of an orbiting spiral and a stationary spiral
- B. Has no valves
- C. More efficient than piston type compressor
- D. Less susceptible to damage due to refrigerant slugging

(CAUTION: On a system with a scroll compressor, do not close the suction service valve to perform a pump down test because the system will go into a vacuum quickly and could develop the "aurora" effect and begin arcing.)

- E. No re-expansion of high pressure vapor

XVI. Evaporative coolers (Transparency 7)

- A. Evaporative coolers use the principle of evaporation to remove sensible heat from air.

Example: When you fan yourself on a hot day, the air movement evaporates sensible heat from the moisture on your face and you feel cooler.

- B. Early evaporative coolers had problems with cabinets rusting out, erratic water distribution, and build-up from water chemicals that could clog a cooler pad or an entire system.

- C. Modern evaporative coolers have rust-proof cabinets, a pump to maintain water distribution, and a bleed-off kit to control chemicals in the water supply.

- D. The bleed-off kits in modern units are so effective in controlling water chemicals that water softeners are not required.

(NOTE: A water softener would actually clog up a modern evaporative cooling unit and decrease system efficiency.)

- E. Modern evaporative units have long lasting cooler pads that are inexpensive and easy to change.

INFORMATION SHEET

- F. Because they do not expend energy in the actual cooling process (evaporation is a natural process), evaporative units are less expensive to operate than refrigerated units with compressors.

(NOTE: Some manufacturers report savings of more than 70% when comparing evaporative unit operation with a comparable refrigerated unit.)

XVII. Evaporative cooling applications

- A. Evaporative cooling works best in areas of low humidity, but effective installations have been placed in high humidity areas such as Georgia and Galveston, Texas.

(NOTE: Humidity is lowest at the hottest time of the afternoon, and this natural phenomena makes evaporative cooling effective in a variety of climates.)

- B. Because evaporative cooling units provide a complete change of air every few minutes, they are popular in schools, factories, churches, and restaurants.
- C. In large, open areas such as stadiums and warehouses, evaporative cooling is about the only form of cooling that can accomplish the job, and do the job economically.
- D. Evaporative cooling units are sometimes used in tandem with refrigerated units:
1. They are used as back-up to the refrigerated system.
 2. They are used during the milder part of the cooling season.
 3. They are used during start-up to purge a building of stale air during really hot weather.
- E. Newer designs in evaporative coolers feature a two-stage system that cools the air twice to achieve temperatures low enough to compare with comparable refrigerated systems. (Figure 1)

INFORMATION SHEET

FIGURE 1

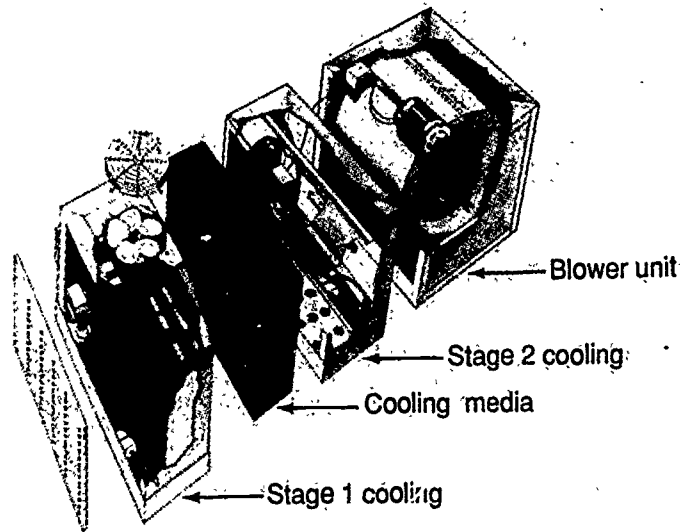

Courtesy ArvinAir, Inc.

XVIII. Refrigerant recovery and recycling

- A. Venting old refrigerant into the atmosphere helps deplete the protective ozone layer above the earth and is in violation of EPA (Environmental Protection Agency) standards.
- B. To avoid improper venting of refrigerants, recovery units are used to draw the old refrigerant out of a system, process it, and store it.
- C. Some recovery units simply store the old refrigerant in an approved refillable container so it can be shipped to a processing plant where it is recycled/reclaimed so it can be used again.
- D. Other recovery units complete the entire process of recovery and recycling/reclaiming at the point of service.
- E. A technician who uses a recovery machine should be trained in the proper use of the unit and especially with the dangers of using anything other than a (Department of Transportation) DOT-approved refillable container.

(CAUTION: Unapproved containers are extremely dangerous and illegal. Always examine recovery unit containers to make sure they have the DOT approval indicated on the containers.)

INFORMATION SHEET

- F. Units vary in their ability to remove contaminants from old refrigerant, but under no circumstances should a technician try to operate recovery equipment in a manner other than specified by the manufacturer.

(NOTE: Recovery/recycling/reclaiming technology is a rapidly growing part of the HVAC industry and technicians who learn about recovery equipment and how to safely operate it will have a very positive addition to their job skills.)

Basic Components of a Cooling System

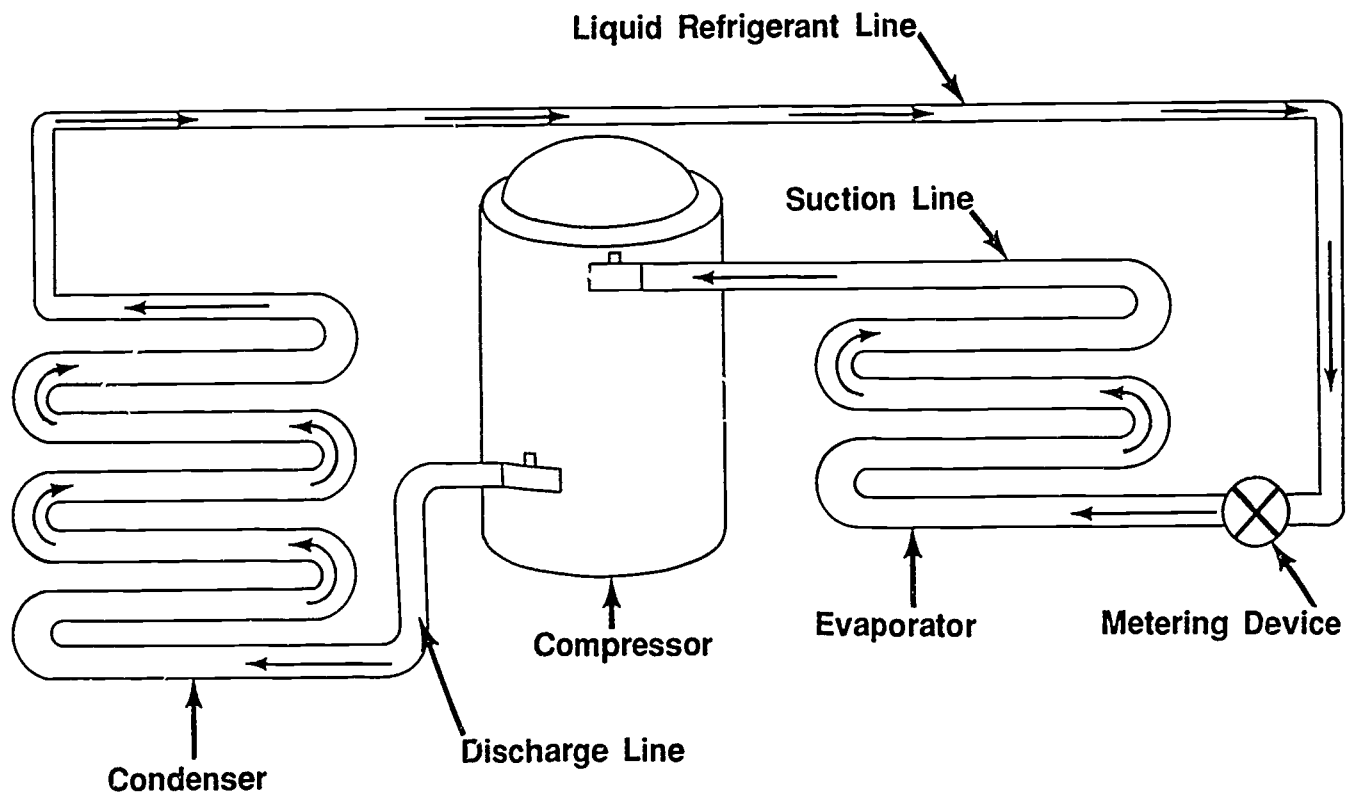

Typical Charging Table

OUTDOOR AMBIENT (°F)	SUCTION PRESSURE AT OUTDOOR SECTION (PSIG)																									
	50	52	54	56	58	60	62	64	66	68	70	72	74	76	78	80	82	84	86	88	90	92	94	96	98	
	SUCTION LINE TEMPERATURE (±3°F.)																									
65	37	42	47	53	59	64	69	71	75	79	82	85														
70	32	37	43	48	53	59	64	69	71	75	79	82	85													
75		33	38	43	49	54	59	65	69	72	76	79	83	85												
80			32	38	43	48	54	59	64	69	72	75	79	81	85											
85				32	38	41	48	53	58	64	69	71	75	78	81	84										
90					35	40	47	52	57	62	65	68	72	75	78	81	85									
95						40	44	49	54	59	62	66	70	73	76	79	82	85								
100							44	48	53	58	63	65	69	72	75	78	81	85								
105								42	47	50	55	60	66	69	71	75	78	80	83	86						
110									45	50	55	60	65	68	70	73	76	79	82							
115														51	55	60	63	66	69	72	75	78	81	84		

(NOTE: Suction temperature reading should be taken at the compressor.)

Manufacturer's Charging Specifications

MODEL NO. CA3030SKA1/867.800430 CA3030QKA1/867.800530 CA3030VKA1/867.800040		PERFORMANCE DATA: 80° D.B. INDOOR											
SPECIFICATIONS		Low Wet Bulb (63°)					High Wet Bulb (69°)						
ELECTRICAL VOLTAGE/CYCLES/PHASE BRANCH CIRCUIT AMPACITY WIRE SIZE/MAX FT TIME DELAY FUSE SIZE MAX FUSE/HACR BREAKER BOOST TRANSFORMER	208-230/60/1 17.9 #12/46 20 30 9T51Y5810	Coil - BA3030/867.808980/867.809080					RATED 1050 CFM ES P WET 34M *CHG R-22 70 OZ						
		AMB. OUTD.	SENS. TOTAL RATIO	APPX. MBTUH	PSIG SUCT	PSIG LIQ	UNIT AMP	AMB. OUTD.	SENS. TOTAL RATIO	APPX. MBTUH	PSIG SUCT	PSIG LIQ	UNIT AMP.
		75	0.853	28367	64	186	12.5	75	0.587	31044	73	201	13.2
95	0.886	27158	70	241	14.1	95	0.616	29722	80	260	14.9		
115	0.905	23659	76	299	15.7	115	0.635	25903	86	323	16.5		
FAN MOTOR HP / TYPE FLA/LRA /RPM RUN CAP. MFD /VOLTS	1/6 PSC 1.03/2.0 1100/CCW 5/370	Coil - EAS3030/867.811480/867.811550					RATED 1050 CFM Δ P WET .18 *CHG R-22 70 OZ						
		75	0.853	28367	64	186	10.9	75	0.587	31044	73	201	11.5
		95	0.886	27158	70	241	12.4	95	0.616	29722	80	260	13.0
115	0.905	23669	76	299	13.8	115	0.635	25903	86	323	14.5		
COMPRESSOR FLA/LRA RUN CAP. MFD /VOLTS ACC. START KIT	COPELAND 13.5/71.0 35/370 NAMA001SC	Coil -					RATED CFM Δ P WET *CHG R-22 - OZ						
SERVICE DRIERS LIQUID /CHARGE SUCTION	16 CU IN/11 oz 30 SQ IN	Coil					RATED CFM Δ P WET *CHG R-22 - OZ						
LINE SIZE (50 FT) MAX) LIQUID SUCTION	5/16 3/4	Coil					RATED CFM Δ P WET *CHG R-22 - OZ						
*REF CHARGE IN-22 OZ) SEE COIL *Lines not included, .30 oz /ft 1/4 liq line .45 oz /ft 5/16 liq line 60 oz /ft 3/8 liq line		Coil -					RATED CFM Δ P WET *CHG R-22 - OZ						
CLEARANCES SEE INSTALLATION INSTRUCTIONS		Coil					RATED CFM Δ P WET *CHG R-22 - OZ						
NOTE OPTIMUM OPERATING CHARGE WILL PRODUCE 15° 25°F SUCTION LINE SUPERHEAT AT COMPRESSOR WITH 82°F OUTDOOR AMB 80°F D.B 67°F W.B INDOOR TEMPERATURES AT RATED AIRFLOW						1053028 8-10-87 AH-1							

Courtesy Inter-City Products Corporation (USA)

Net Coil Capacity Versus Percent Refrigerant

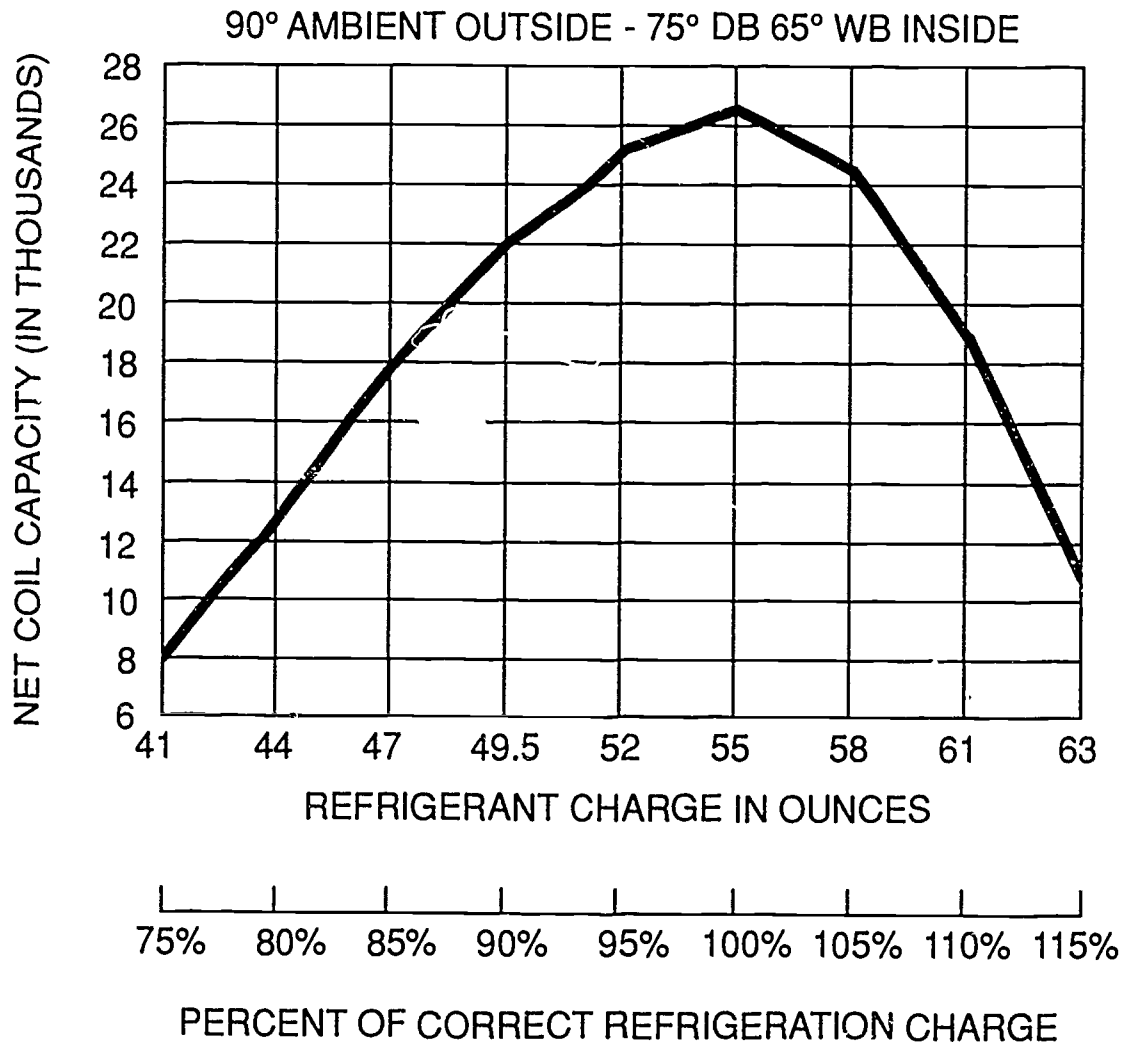

Air Conditioning & Refrigeration Institute, *Refrigeration and Air-Conditioning, Second Edition*. ©1987. Reprinted by permission of Prentice Hall, Inc., Englewood Cliffs, New Jersey.

EER Rating Versus Percent Refrigeration Charge

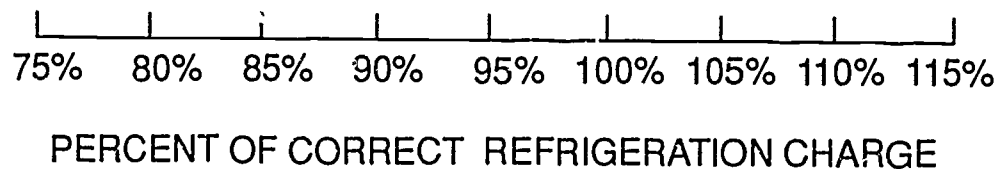
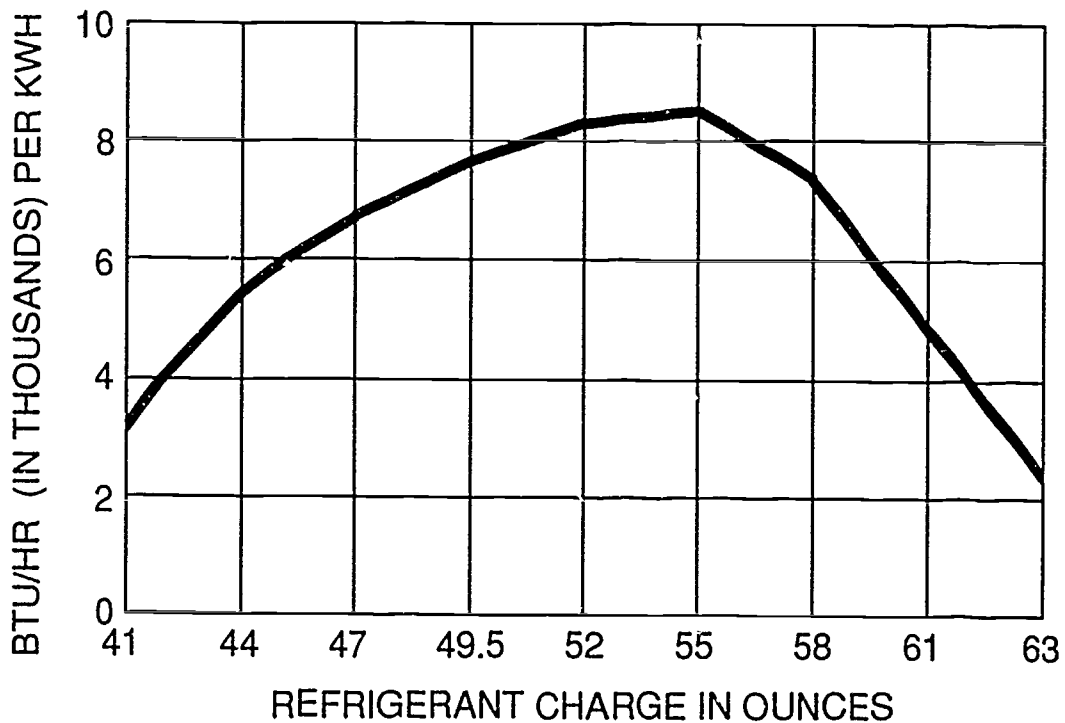

Air Conditioning & Refrigeration Institute, *Refrigeration and Air-Conditioning, Second Edition*. ©1987. Reprinted by permission of Prentice Hall, Inc., Englewood Cliffs, New Jersey.

Compliant Scroll[®] Compressor

Scroll Gas Flow

Compression in the scroll is created by the interaction of an orbiting spiral and a stationary spiral. Gas enters an outer opening as one of the spirals orbits.

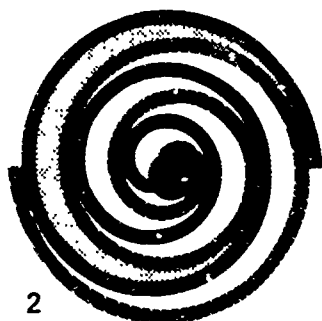

The open passage is sealed off as gas is drawn into the spiral.

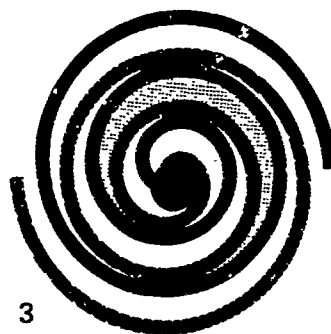

As the spiral continues to orbit, the gas is compressed into an increasingly smaller pocket.



By the time the gas arrives at the center port, discharge pressure has been reached.

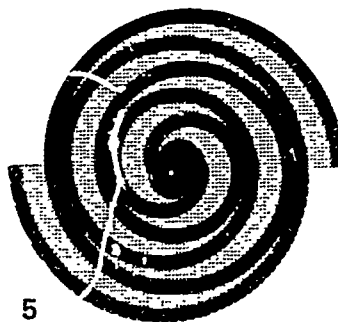

Actually, during operation, all six gas passages are in various stages of compression at all times, resulting in nearly continuous suction and discharge.

Courtesy Copeland Corporation, 1990. Copeland is a registered trademark, and Compliant Scroll is a trademark of Copeland Corporation.

Evaporative Cooling System

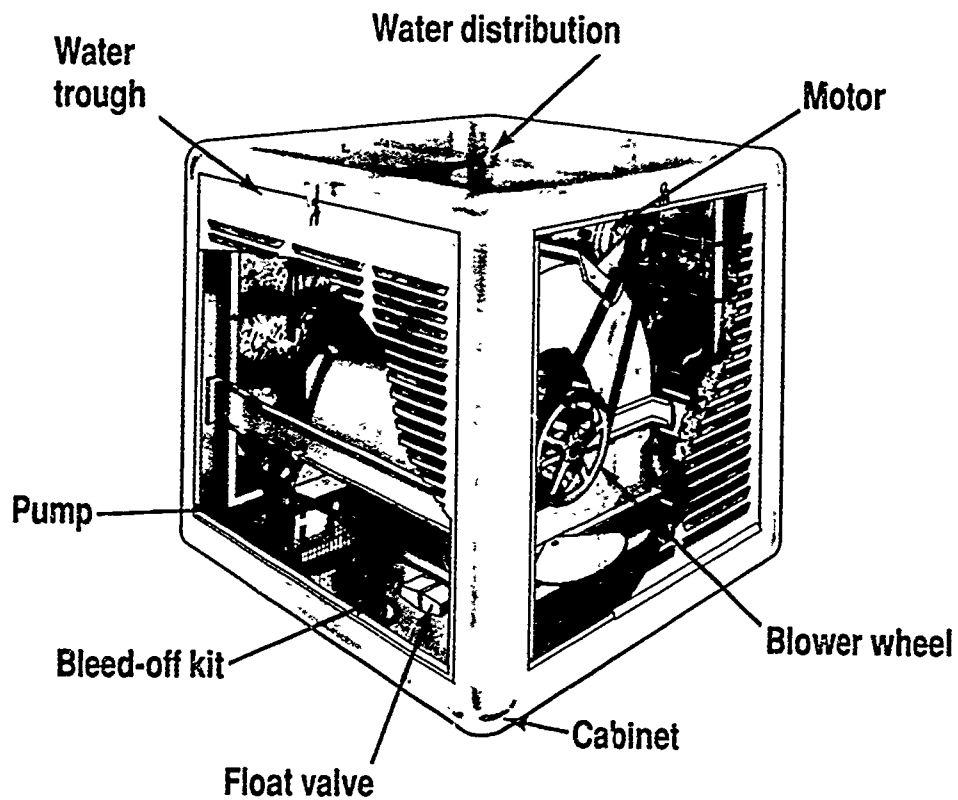

Courtesy ArvinAir Inc.

COOLING SYSTEMS
UNIT XIII

ASSIGNMENT SHEET #1 — TRACE THE COOLING CIRCUIT ON A SINGLE
PHASE PACKAGE HEAT/COOL UNIT

Directions: Use a colored pencil to trace the control and power wiring of the cooling unit shown in the following ladder diagram.

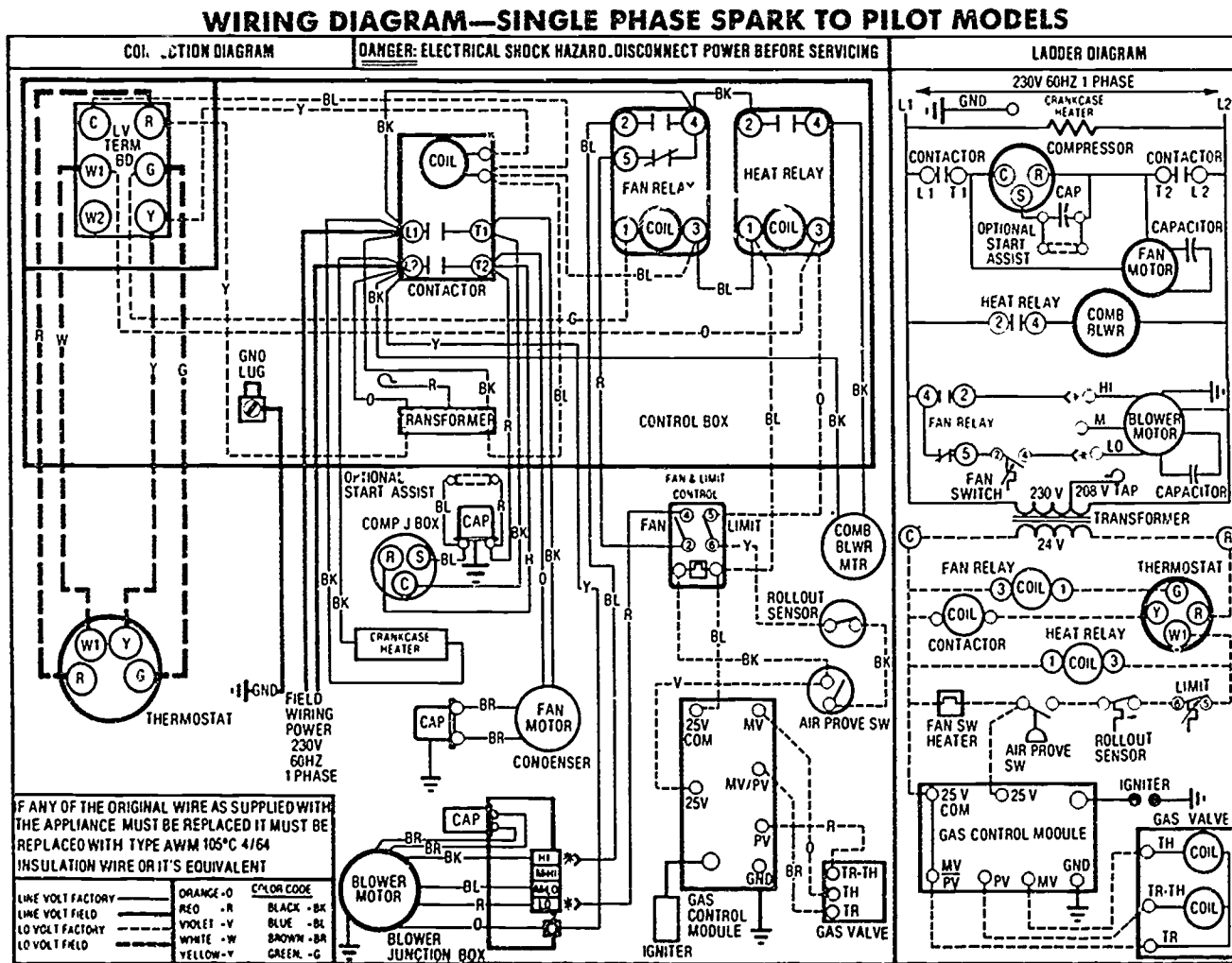

COOLING SYSTEMS UNIT XIII

ASSIGNMENT SHEET #2 — TRACE THE COOLING CIRCUIT ON A 7½ TON THREE PHASE ROOFTOP UNIT

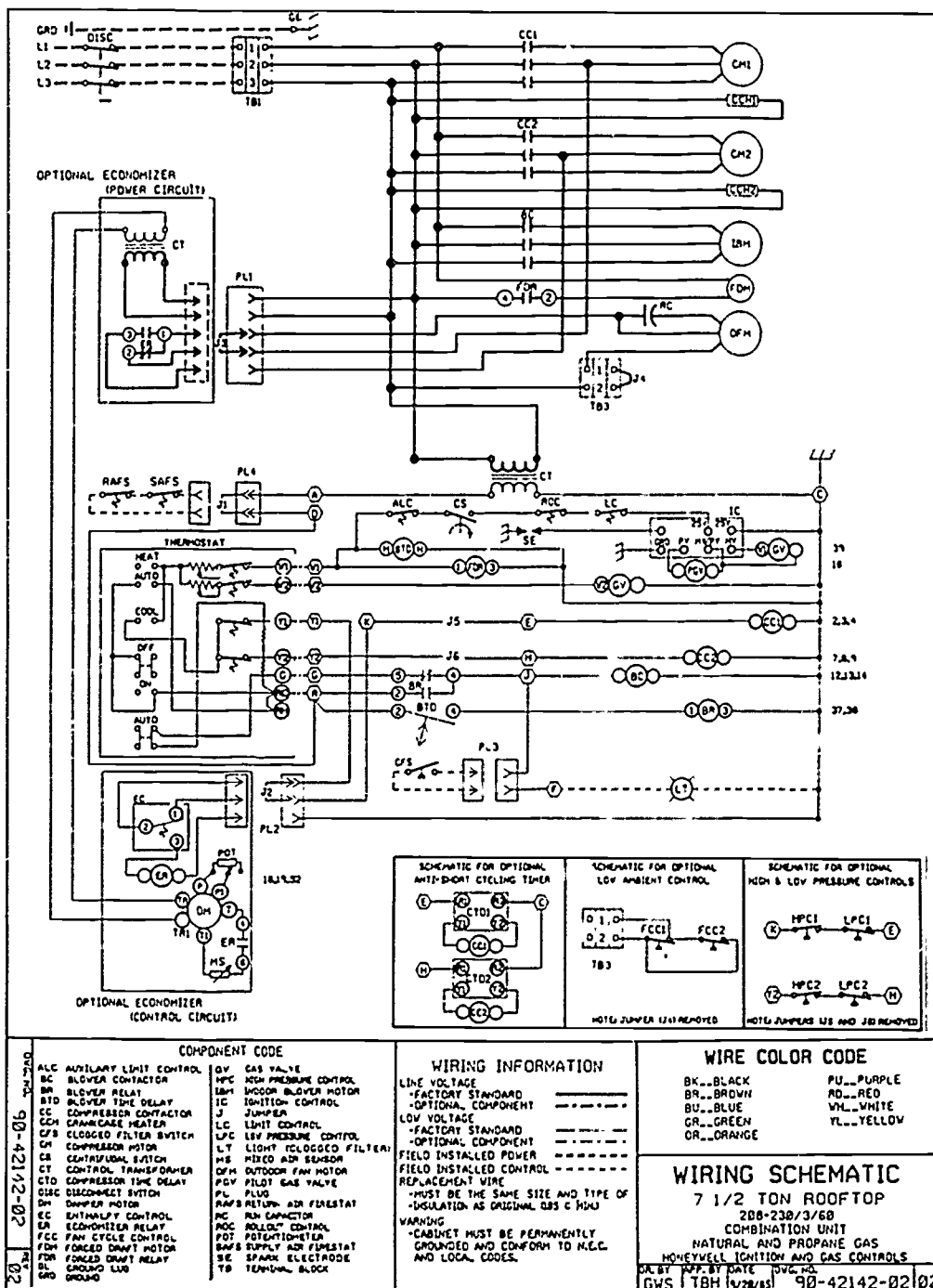

Courtesy Inter-City Products Corporation (USA)

WIRING DIAGRAM—SINGLE PHASE SPARK TO PILOT MODELS

Assignment Sheet #1

ANSWERS TO ASSIGNMENT SHEETS
COOLING SYSTEMS
UNIT XIII

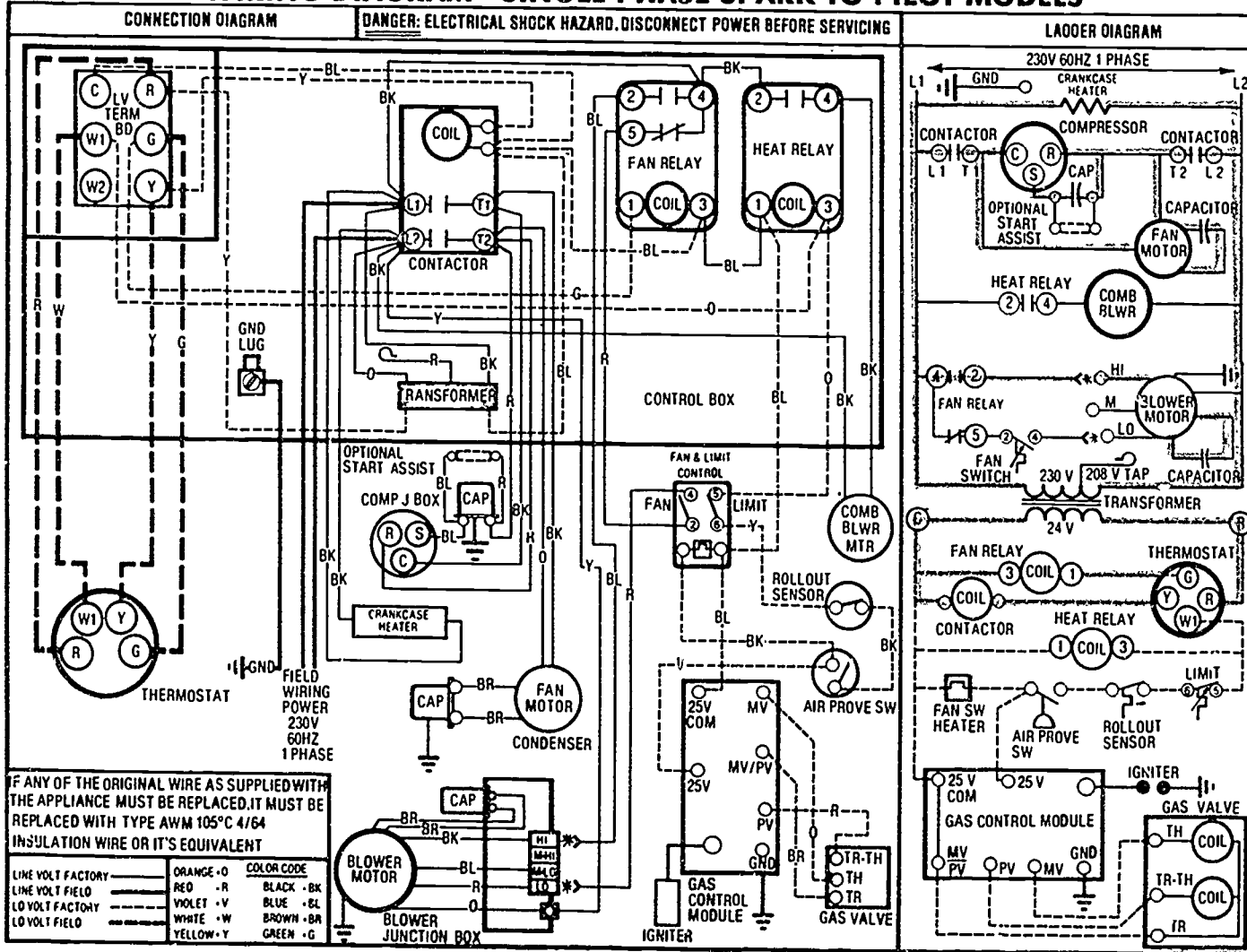

Courtesy Intra-City Products Corporation (USA)

ANSWERS TO ASSIGNMENT SHEETS

Assignment Sheet #2

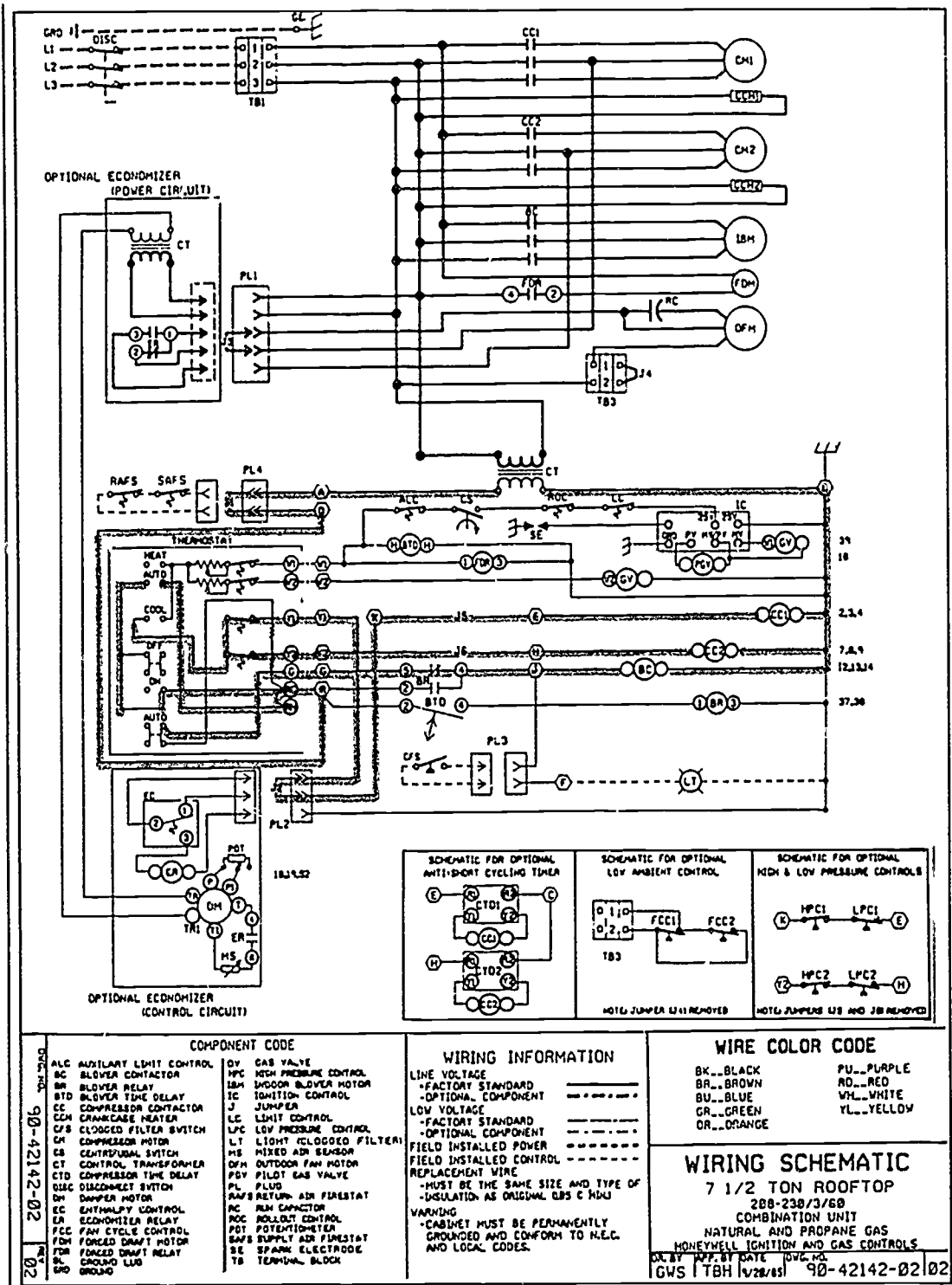

Courtesy Inter-City Products Corporation (USA)

**COOLING SYSTEMS
UNIT XIII**

**JOB SHEET #1 — TROUBLESHOOT AN AIR CONDITIONER CONDENSER
SECTION ON A "NO COOLING" COMPLAINT**

- A. Tools and equipment
1. Service technician's tool pouch/box
 2. VOM and ammeter
 3. Gauge manifold
 4. Gloves
 5. Air conditioner as selected by instructor
 6. Replacement components as required
 7. Safety glasses
- B. Procedure
1. Check for a safe work area and put on safety glasses.
 2. Set thermostat fan switch to ON.
 - a. If the blower fails to start, check the furnace main fuse.
 - b. If the fuse is bad, replace it, and if it's okay, check output from transformer for 24 volts.
 - c. If the transformer is okay, check the line voltage at the blower motor.
 - d. If there is voltage at the blower motor, the blower motor is bad.
 - e. If there is no voltage at the blower motor, check for 24V at the fan relay coil.
 - f. If 24V is present at the fan relay coil and relay contacts are not closing, replace the fan relay.
 3. Confirm that the blower operates normally, and set the thermostat to call for COOLING.
 4. Confirm that the outdoor unit operates normally.
 - a. If the outdoor unit does not run, check for line voltage at the line side of the contactor.
 - b. If there is no line voltage, check the fuses at the outdoor disconnect, and replace as required.

JOB SHEET #1

- c. If the fuses are okay, check for broken wiring or loose connections.
(CAUTION: Remember that you are working with a unit that is energized, so watch your step.)
 - d. If you have voltage at the line side of the contactor, check for 24V at the contactor coil.
 - e. If there is not 24V at the contactor, check for an open high/low pressure switch or other safety device.
 - f. If there is 24V present and the contactor has not closed, replace the contactor.
 - g. If the contactor is closed and you don't have line voltage from the load side of the contactor, replace the contactor.
 - h. If there is line voltage on the load side of the contactor, check to see if the compressor and outdoor fan are running.
 - i. If the compressor and fan are both running but the no cooling complaint continues, the problem could be with an electrical component or a mechanical problem.
5. Check to see if the compressor runs, but the condenser fan does not.
 - a. If the fan does not run, check for line voltage at the fan motor leads.
 - b. If line voltage is present, check the fan capacitor and if it is bad, replace it.
 - c. If the capacitor is good and voltage is present at the fan motor leads, replace the condenser fan motor.
 6. Check to see if the fan runs, but the compressor does not run.
 - a. If the compressor does not run, check the current draw at the compressor leads.
 - b. If there is no current draw, check for a minimum of 197V at the common and run terminals of the compressor.
 - c. If voltage at the compressor terminals is a minimum of 197V, but there is no current draw, turn the power off at the condenser unit disconnect.
 7. Touch the compressor to see how hot it is.
 - a. If the compressor is too hot to touch, it is overheated and the internal overload is probably open, and should be verified by removing the compressor leads and running a continuity check.

JOB SHEET #1

- b. If continuity is present between the start and run terminals, but there is no continuity present between common and the start/run terminals, the compressor is probably open on internal overload.
8. Allow the compressor time to cool and reset.
 - a. If the compressor is cool and there is no continuity between the common start/run terminals, then there are open compressor windings and the compressor must be replaced.
 - b. If the compressor checks out okay after cooling, check the run capacitor and the starting components including the PTCR assist or potential relay and start capacitor.
9. Replace starting components as required.
10. Turn the condenser unit disconnect back ON.
11. Check the nameplate for the locked rotor amp draw and measure the draw at the compressor.
 - a. If the amp draw is high, there is a locked rotor condition and the compressor should be replaced.
 - b. If the amp draw is proper, and the compressor is running, the problems are elsewhere in the system and troubleshooting should continue.
12. Check all operating pressures to verify a proper refrigerant charge.
 - a. If operating pressures indicate high suction and low head, it indicates bad valves in the compressor, but other tests should be made before condemning the compressor.
 - b. If operating pressures are incorrect it could indicate an improper charge, dirty coils, blocked air flow, or other problems that require further troubleshooting.

(NOTE: See the other job sheets in this unit for other troubleshooting activities.)
13. Clean coils and replace filters as required.
14. Verify that the no cooling complaint has been corrected.
- Have your instructor evaluate your troubleshooting.
15. Clean tools and area and return tools and equipment to proper storage.

**COOLING SYSTEMS
UNIT XIII****JOB SHEET #2 — USE A CHARGING TABLE TO CHECK THE CHARGE
IN A CAPILLARY COOLING SYSTEM****A. Tools and equipment**

1. Service technician's tool pouch/box
2. Insulation tape
3. Refrigeration thermometer or thermometer feeler bulb
4. Gauges
5. Pencil and paper
6. Cooling system as selected by instructor
7. Safety glasses

B. Procedure

1. Check for a safe work area and put on safety glasses.

(NOTE: If you don't have manufacturer's charging specifications, work with the charging chart in Figure 1 that accompanies this job sheet.)

2. Attach a refrigeration thermometer or thermometer feeler bulb securely to the system's suction line where it enters the condensing unit.
3. Insulate around the connection with tape to insure an accurate reading.
4. Connect gauges.
5. Start unit and make visual check for air flow at indoor unit by verifying blower operation and making sure outlets are not obstructed.
6. Allow unit to operate 10 to 15 minutes to stabilize.
7. Read and record:
 - a. Suction line pressure _____.
 - b. Ambient temperature _____.
 - c. Suction line temperature _____.
8. Compare figures in the charging table with suction line pressure and ambient temperature. (Figure 1)

(NOTE: The unit suction line temperature should be within 3°F of the chart reading for the unit to indicate a proper charge.)

JOB SHEET #2

9. Compare system readings with chart readings; if unit suction line temperature is higher than 3°F over the value given, the system is undercharged.
10. Compare system readings with chart readings; if unit suction line temperature is lower than 3°F below the value given, the system is overcharged.
 - a. If pressures are incorrect check for low indoor unit air flow.
 - b. If filters or coil are dirty, clean the coil and replace dirty filters.
 - c. If system readings are off the chart, look for air flow problems.
11. Establish a condition of undercharge or overcharge and continue.
12. Check for restrictions in refrigerant line.
 - a. If the outdoor coil is dirty, it will affect operating pressures and temperatures.
 - b. If there is no air flow problem, troubleshoot for a clogged drier or strainer or problems with metering devices.
- Have your instructor check your work.
13. Turn off unit and remove gauges.
14. Clean up area and return tools.

C41

JOB SHEET #2

FIGURE 1

OUTDOOR AMBIENT (°F)	SUCTION PRESSURE AT OUTDOOR SECTION (PSIG)																								
	50	52	54	56	58	60	62	64	66	68	70	72	74	76	78	80	82	84	86	88	90	92	94	96	98
	SUCTION LINE TEMPERATURE (± 3°F)																								
65	37	42	47	53	59	64	69	71	75	79	82	85													
70	32	37	43	48	53	59	64	69	71	75	79	82	85												
75		33	38	43	49	54	59	65	69	72	76	79	83	85											
80			32	38	43	48	54	59	64	69	72	75	79	81	85										
85				32	38	41	48	53	58	64	69	71	75	78	81	84									
90					35	40	47	52	57	62	65	68	72	75	78	81	85								
95						40	44	49	54	59	62	66	70	73	76	79	82	85							
100								44	48	53	58	63	65	69	72	75	78	81	85						
105									42	47	50	55	60	66	69	71	75	78	80	83	86				
110										45	50	55	60	65	68	70	73	76	79	82					
115														51	55	60	63	66	69	72	75	78	81	84	

**COOLING SYSTEMS
UNIT XIII****JOB SHEET #3 — PERFORM MAINTENANCE ON AN AIR CONDITIONER****A. Tools and equipment**

1. Technician's tool pouch/box
2. Ammeter-voltmeter-ohmmeter
3. Gauge manifold
4. Gloves
5. Safety glasses

B. Procedure

1. Check for a safe work area and put on safety glasses.
2. Follow procedure for periodic maintenance on an indoor section.
3. Remove panel and control box cover from condensing unit.

(NOTE: Some units require that all panels be in place to assure that maximum air is channeled to the condenser coil.)
4. Measure amperage of condenser fan and compare with fan motor specifications on nameplate.
5. Measure amperage of compressor and compare with compressor motor specifications on nameplate.
6. Kill power to unit, gain access to motor, and oil according to manufacturer's instructions.

(NOTE: Many condenser fan motors are the sealed type and cannot be lubricated in the field.)
7. Touch crankcase heater to determine condition.

(CAUTION: The heater may be hot.)
8. Inspect condenser coil, clean with coil cleaner if dirty and comb out bent fins if necessary.
9. Inspect terminals on capacitors, contactor, and compressor for corrosion and burning.
10. Check operation of lockout relay if present.

JOB SHEET #3

11. Connect gauge manifold and determine operating pressures, and check charging chart from manufacturer.

(NOTE: Most systems use R-22 refrigerant; nevertheless, there are some manufacturers which use other refrigerants; be positive which refrigerant is used before adding any; refrigerant data is usually on the nameplate.)

12. Check operation of high pressure switch if one is present.
13. Diagnose and correct the problem if pressures are not correct.
14. Remove gauges.
15. Replace panels and screws that were removed.
- Have your instructor check your work.
16. Clean the work and put tools away.

C44

**COOLING SYSTEMS
UNIT XIII**

PRACTICAL TEST #1

**JOB SHEET #1 — TROUBLESHOOT AN AIR CONDITIONER CONDENSER
SECTION ON A "NO COOLING" COMPLAINT**

Student's name _____ Date _____

Evaluator's name _____ Attempt No. _____

Student instructions: When you are ready to perform this task, ask your instructor to observe the procedure and complete this form. All items listed under "Process Evaluation" must receive a "Yes" for you to receive an overall performance evaluation.

PROCESS EVALUATION

(EVALUATOR NOTE: Place a check mark in the "Yes" or "No" blanks to designate whether or not the student has satisfactorily achieved each step in this procedure. If the student is unable to achieve this competency, have the student review the materials and try again.)

The student:	Yes	No
1. Checked fuse and transformer.	<input type="checkbox"/>	<input type="checkbox"/>
2. Checked line voltage to blower motor.	<input type="checkbox"/>	<input type="checkbox"/>
3. Verified indoor section operation.	<input type="checkbox"/>	<input type="checkbox"/>
4. Checked condenser circuit fuse.	<input type="checkbox"/>	<input type="checkbox"/>
5. Made complete compressor check.	<input type="checkbox"/>	<input type="checkbox"/>
6. Checked for high head pressure.	<input type="checkbox"/>	<input type="checkbox"/>
7. Checked out hard start kit, capacitor, and compressor windings.	<input type="checkbox"/>	<input type="checkbox"/>

EVALUATOR'S COMMENTS: _____

JOB SHEET #1 PRACTICAL TEST

PRODUCT EVALUATION

(EVALUATOR NOTE: Rate the student on the following criteria by circling the appropriate numbers. Each item must be rated at least a "3" for mastery to be demonstrated. (See performance evaluation key below.) If the student is unable to demonstrate mastery, student materials should be reviewed and another test procedure must be submitted for evaluation.)

Criteria:

Basic electrical troubleshooting	4	3	2	1
Indoor section operation check	4	3	2	1
Fan, compressor, and contactor check	4	3	2	1
High pressure cutout check	4	3	2	1

EVALUATOR'S COMMENTS: _____

PERFORMANCE EVALUATION KEY

- 4 — **Skilled** — Can perform job with no additional training.
- 3 — **Moderately skilled** — Has performed job during training program; limited additional training may be required.
- 2 — **Limited skill** — Has performed job during training program; additional training is required to develop skill.
- 1 — **Unskilled** — Is familiar with process, but is unable to perform job.

(EVALUATOR NOTE: If an average score is needed to coincide with a competency profile, total the designated points in "Product Evaluation" and divide by the total number of criteria.)

646

**COOLING SYSTEM
UNIT XIII**

PRACTICAL TEST #2

**JOB SHEET #2 — USE A CHARGING TABLE TO CHECK THE CHARGES IN A
CAPILLARY COOLING SYSTEM**

Student's name _____ Date _____

Evaluator's name _____ Attempt No. _____

Student instructions: When you are ready to perform this task, ask your instructor to observe the procedure and complete this form. All items listed under "Process Evaluation" must receive a "Yes" for you to receive an overall performance evaluation.

PROCESS EVALUATION

(EVALUATOR NOTE: Place a check mark in the "Yes" or "No" blanks to designate whether or not the student has satisfactorily achieved each step in this procedure. If the student is unable to achieve this competency, have the student review the materials and try again.)

The student:	Yes	No
1. Set up suction line for proper check.	<input type="checkbox"/>	<input type="checkbox"/>
2. Recorded required pressure and temperature.	<input type="checkbox"/>	<input type="checkbox"/>
3. Compared readings with charging table norms.	<input type="checkbox"/>	<input type="checkbox"/>
4. Evaluated readings.	<input type="checkbox"/>	<input type="checkbox"/>
5. Established a condition of (undercharge) (overcharge). Note: Circle one.	<input type="checkbox"/>	<input type="checkbox"/>
6. Checked for low indoor air flow.	<input type="checkbox"/>	<input type="checkbox"/>
7. Checked for refrigerant line restrictions.	<input type="checkbox"/>	<input type="checkbox"/>

EVALUATOR'S COMMENTS: _____

JOB SHEET #2 PRACTICAL TEST

PRODUCT EVALUATION

(EVALUATOR NOTE: Rate the student on the following criteria by circling the appropriate numbers. Each item must be rated at least a "3" for mastery to be demonstrated. (See performance evaluation key below.) If the student is unable to demonstrate mastery, student materials should be reviewed and another test procedure must be submitted for evaluation.)

Criteria:

System preparation	4	3	2	1
Pressure and temperature recordings	4	3	2	1
System evaluation	4	3	2	1

EVALUATOR'S COMMENTS:

PERFORMANCE EVALUATION KEY

- | |
|--|
| <p>4 — Skilled — Can perform job with no additional training.
 3 — Moderately skilled — Has performed job during training program; limited additional training may be required.
 2 — Limited skill — Has performed job during training program; additional training is required to develop skill.
 1 — Unskilled — Is familiar with process, but is unable to perform job.</p> |
|--|

(EVALUATOR NOTE: If an average score is needed to coincide with a competency profile, total the designated points in "Product Evaluation" and divide by the total number of criteria.)

**COOLING SYSTEMS
UNIT XIII**

PRACTICAL TEST #3

JOB SHEET #2 — PERFORM MAINTENANCE ON AN AIR CONDITIONER

Student's name _____ Date _____

Evaluator's name _____ Attempt No. _____

Student instructions: When you are ready to perform this task, ask your instructor to observe the procedure and complete this form. All items listed under "Process Evaluation" must receive a "Yes" for you to receive an overall performance evaluation.

PROCESS EVALUATION

(EVALUATOR NOTE: Place a check mark in the "Yes" or "No" blanks to designate whether or not the student has satisfactorily achieved each step in this procedure. If the student is unable to achieve this competency, have the student review the materials and try again.)

The student:	Yes	No
1. Checked indoor section properly.	<input type="checkbox"/>	<input type="checkbox"/>
2. Measured and verified condenser fan amperage.	<input type="checkbox"/>	<input type="checkbox"/>
3. Measured and verified compressor amperage.	<input type="checkbox"/>	<input type="checkbox"/>
4. Oiled condenser fan.	<input type="checkbox"/>	<input type="checkbox"/>
5. Inspected and cleaned condenser coil.	<input type="checkbox"/>	<input type="checkbox"/>
6. Checked lockout relay operation.	<input type="checkbox"/>	<input type="checkbox"/>
7. Used gauge manifold to check operating pressures.	<input type="checkbox"/>	<input type="checkbox"/>
8. Corrected problems as required.	<input type="checkbox"/>	<input type="checkbox"/>

EVALUATOR'S COMMENTS: _____

JOB SHEET #3 PRACTICAL TEST

PRODUCT EVALUATION

(EVALUATOR NOTE: Rate the student on the following criteria by circling the appropriate numbers. Each item must be rated at least a "3" for mastery to be demonstrated. (See performance evaluation key below.) If the student is unable to demonstrate mastery, student materials should be reviewed and another test procedure must be submitted for evaluation.)

Criteria:

Indoor section operation verification	4	3	2	1
Amperage measurements	4	3	2	1
Condenser fan and condenser coil check	4	3	2	1
Operating pressure measurements	4	3	2	1

EVALUATOR'S COMMENTS: _____

PERFORMANCE EVALUATION KEY
4 — Skilled — Can perform job with no additional training.
3 — Moderately skilled — Has performed job during training program; limited additional training may be required.
2 — Limited skill — Has performed job during training program; additional training is required to develop skill.
1 — Unskilled — Is familiar with process, but is unable to perform job.

(EVALUATOR NOTE: If an average score is needed to coincide with a competency profile, total the designated points in "Product Evaluation" and divide by the total number of criteria.)

650

**COOLING SYSTEMS
UNIT XIII**

TEST

NAME _____

SCORE _____

1. Match terms on the right with their correct definitions.

- | | | | |
|----------|--|-----|----------------------------|
| _____ a. | A gauge port made like an automobile tire valve | 1. | Scroll compressor |
| _____ b. | A low wattage device that boils refrigerant out of the compressor crankcase | 2. | PTCR |
| _____ c. | A normally closed relay used to open a protective circuit while the relay coil is energized | 3. | SEER |
| _____ d. | A starting relay and capacitor added to a compressor circuit | 4. | Crankcase heater |
| _____ e. | A tank installed in the suction line to hold liquid refrigerant to guard against flood back to the compressor | 5. | High side |
| _____ f. | A tank in a refrigeration system for storing liquid refrigerant | 6. | Charging tables |
| _____ g. | Lines which connect a condensing unit to a cooling coil | 7. | Schrader valve |
| _____ h. | Closes the liquid line during the "off" cycle | 8. | Start kit |
| _____ i. | The low pressure part of the refrigeration system, namely the evaporator coil and suction line | 9. | Low side |
| _____ j. | The high pressure part of the refrigeration system, namely the discharge line, condenser coil, and liquid line | 10. | Evaporative cooling |
| _____ k. | Seasonal energy efficiency ratio | 11. | Liquid line solenoid valve |
| _____ l. | A solid state start assist device to give the compressor additional starting torque | 12. | Receiver |
| _____ m. | A cooling process that passes air across a wetted pad or water spray | 13. | Refrigerant lines |
| | | 14. | Lockout relay |
| | | 15. | Suction line accumulator |
| | | 16. | Refrigerant reclaiming |
| | | 17. | Variable speed compressor |

TEST

- _____ n. Graphs or tables listing proper operating pressures at various operating conditions
- _____ o. A compressor that has no pistons and compresses gas by use of a stationary scroll and an identical scroll that orbits the stationary one
- _____ p. A compressor where RPM can be adjusted to modify the refrigerant pumping capacity
- _____ q. A device used to remove old refrigerant from a system, clean it, and prepare it for re-use or sometimes a unit to simply remove refrigerant for proper disposal

2. Complete a list of basic mechanical components of a cooling system.

- a. Compressor
- b. Suction line
- c. Discharge line
- d. _____
- e. _____
- f. _____

3. Complete a list of additional components found on some residential and light commercial units.

- a. Liquid line drier
- b. Suction line drier
- c. _____
- d. _____

;

TEST

4. Match electrical components with their functions.

- | | | | |
|----------|---|-----|----------------------------|
| _____ a. | Controls unit operation; usually 24 volt, wall mounted | 1. | Start kit |
| _____ b. | Steps the line voltage down to 24 volts control circuit purposes | 2. | Low pressure switch |
| _____ c. | A heavy duty relay that closes and opens the line voltage circuit to the compressor | 3. | Condenser fan motor |
| _____ d. | Monitors the head pressure and stops compressor operation if head pressure is excessive | 4. | Evaporator blower motor |
| _____ e. | Monitors the suction pressure and stops compressor operation should suction pressure drop too low | 5. | Transformer |
| _____ f. | A low wattage heater in contact with the sump of the compressor adding heat during the "off cycle" to prevent liquid migration to the compressor | 6. | Lockout relay |
| _____ g. | A potential relay, start capacitor, and necessary wiring which adds more starting torque to the compressor | 7. | Thermostat and sub-base |
| _____ h. | Adds some starting torque to the compressor, but not as much as the start capacitor, and sometimes referred to as a "start assist" device | 8. | Run capacitor |
| _____ i. | Used to move air over the condenser and may be two speed on some units which will require a fan speed control switch | 9. | Overload protector |
| _____ j. | Device to allow two speed condenser fan motor to operate on low speed at lower ambient temperature | 10. | PTCR |
| _____ k. | An electrical switching device to shut down compressor operation if the motor draws too much current | 11. | Crankcase heater |
| _____ l. | A normally closed relay used to open a protective circuit while the relay coil is energized, requiring the coil circuit to be de-energized before unit operation will start again | 12. | High pressure switch |
| | | 13. | Fan speed control |
| | | 14. | Contactora |
| | | 15. | Liquid line solenoid valve |

TEST

- m. Electrical device used in the running circuit of a single phase permanent split capacitor motor
 - n. Used to move air over the evaporator; located in the furnace or indoor section
 - o. Electrically operated valve to close the liquid line during the "off cycle", usually found on light commercial applications
5. Arrange in order the steps in a cooling cycle. Place the correct sequence number in the appropriate blank.
- a. At the same time, the contactor coil is also energized from the thermostat, closing the line voltage circuit to the compressor and condenser fan motor.
 - b. When temperature in the conditioned space is lowered to set point, the thermostat is "satisfied" and opens the control circuits to complete the cycle.
 - c. The system thermostat, responding to room temperature and heat from the cooling anticipator, closes a switch to "call for cooling."
 - d. The indoor fan relay coil is energized, closing a set of contacts which complete the line voltage circuit to the evaporator blower motor for cooling speed.
6. Select true statements concerning indoor fan operation. Place an "X" beside each true statement.
- a. When the thermostat is set to "auto", the indoor fan will cycle with the condensing unit.
 - b. When set to "on" or "cont" on the thermostat, the indoor fan will run continuously regardless of condensing unit operation.
 - c. When set for continuous operation with a multi-speed fan motor, the indoor fan will run at cooling speed.
 - d. Few commercial structures ever use continuous fan operation.

654

TEST

7. Match compressor motor failures with ways to detect them.

- | | | |
|----------|--|---|
| _____ a. | 1) These windings can be detected by connecting an ohmmeter to the motor terminals and reading infinite resistance. | 1. Grounded windings
2. Open windings
3. Shorted windings |
| | 2) If equipped with an internal line voltage overload, a hot compressor may show "open" at the common terminal, but show resistance from the start to run terminals. | |
| | 3) Do not condemn a compressor with an internal overload until the compressor cools down and is checked again. | |
| | 4) Three phase motors have the same ohm readings between terminals. | |
| _____ b. | 1) These can be detected by connecting an ohmmeter to the compressor motor terminals and looking for a zero reading or near zero resistance of the motor windings. | |
| | 2) A perfectly good winding will have a low resistance, so care must be taken with an ohmmeter check. | |
| _____ c. | 1) These can be detected by connecting an ohmmeter to ground and checking each motor terminal; any reading means the winding has this condition. | |
| | 2) The copper tubing at the compressor is a good ground point to use when checking for these windings from the motor terminals. | |

TEST

8. Match compressor mechanical failures with ways to detect them.

- | | |
|---|--|
| <p>_____ a. Can be detected by checking current draw and reading locked rotor amps during a stalled condition:</p> <p>1) It may be necessary to install a "start kit" if the unit is not equipped with one.</p> <p>2) Sometimes the compressor may be "bumped" with a start capacitor to get it started initially and then it may run properly.</p> | <p>1. Broken motor shaft</p> <p>2. Leaking valves or head gasket</p> <p>3. Locked rotor</p> <p>4. Tight compressor</p> |
| <p>_____ b. Can be detected by reading the same pressure on both refrigerant gauges while compressor is running.</p> | |
| <p>_____ c. Can be detected by less than normal difference between head pressure and suction pressure.</p> <p>1) Feeling the suction line heat up near the compressor immediately after shut down is another indicator.</p> <p>2) You may hear the gas leaking by the valves in the compressor.</p> | |
| <p>_____ d. Can be determined if the compressor still won't start after all efforts have failed.</p> <p>1) Be sure to check voltage during locked rotor conditions.</p> <p>2) Be sure voltage is not below the minimum specified by the manufacturer.</p> | |

TEST

9. Solve problems concerning causes of compressor failures. Select the best solution to each of the following.
- a. You tell a customer that a compressor has failed because of liquid slugging. Now, the customer wants you to explain liquid slugging, so you say what?
_____.
- 1) It's the result of inferior refrigerant.
 - 2) The primary cause is refrigerant migration into the oil during the "off" cycle.
 - 3) It happens when a system runs often.
- b. You tell a customer that a compressor has failed because of liquid washout. Now, the customer wants you to explain liquid washout, so you say what?
_____.
- 1) It means oil is leaking out of the compressor.
 - 2) It means that refrigerant is heating up and causing compressor burnout.
 - 3) It is the result of refrigerant washing oil off wearing surfaces.
- c. You tell a customer that the system motor has failed because of a spot burn. Now the customer wants you to explain a spot burn, so you say what?
_____.
- 1) The motor is burned in only one spot.
 - 2) It could mean a short between windings, between wires, within a winding, or to ground.
 - 3) Terminals have shorted out and burned.
- d. You tell a customer that the system motor has failed because of a general burn. The customer wants a better explanation of "general burn", so you say
_____.
- 1) It could be windings have overheated or burned, or it may be a result of voltage problems or inadequate motor cooling.
 - 2) It's caused by a faulty cutout switch.
 - 3) It means the motor is burned out in several different places for several different reasons.

TEST

10. Match problems in condensing units with their possible causes.

- | | | |
|----------|--|---------------------------------------|
| _____ a. | 1) Loose mechanical fittings | 1. Condenser fan motor |
| | 2) Improper sweat joints | 2. Refrigerant leaks |
| | 3) Nail hole in refrigerant line somewhere in building | 3. Run capacitor |
| _____ b. | 1) Worn or seized bearings due to lack of lubrication | 4. Start capacitor or potential relay |
| | 2) Open motor windings | 5. Crankcase heater |
| | 3) Grounded motor windings | 6. Contactor |
| | 4) Fan blade out of balance | 7. Condenser coil |
| | 5) Fan blade not positioned properly | |
| | 6) Capacitor failure may cause motor to overheat and motor still be okay | |
| _____ c. | 1) Capacitor terminal burned off | |
| | 2) Capacitor open | |
| | 3) Capacitor shorted | |
| | 4) Relay contacts stuck closed | |
| | 5) Relay contacts won't make | |
| | 6) Relay coil open | |
| _____ d. | 1) Open | |
| | 2) Shorted | |
| | 3) Grounded | |
| | 4) Changed capacitance | |
| _____ e. | 1) Burned points make poor contact | |
| | 2) Points stuck together from arcing | |
| | 3) Sticking carriage | |
| | 4) Open holding coil | |
| | 5) Shorted holding coil | |
| | 6) Insects between these | |

TEST

- _____f. 1) Open
- 2) Shorted
- _____g. 1) Bent coil fins should be combed out
- 2) Corrosion of metals due to chemical reaction

11. Select true statements concerning functions of low side section components in an air conditioner. Place an "X" beside each true statement.

(NOTE: For a statement to be true, all parts of the statement must be true.)

- _____a. Blower section
 - 1) Moves air from occupied space through the filter and cooling coil.
 - 2) Returns conditioned air to occupied space.
- _____b. Cooling coil
 - 1) Removes heat and moisture from the air passing through it.
 - 2) When installed in an upflow or counterflow furnace, the cooling coil must be shaped to allow condensed moisture to cling to the fins and drip into a condensate drain pan.
 - 3) When installed in a horizontal furnace, the cooling coil is shaped to allow condensed moisture to drip downward perpendicular to the air flow through the coil.
 - 4) An auxiliary drain pan should be installed below the primary drain and have its own drain lines on horizontal applications.
- _____c. Condensate pan — Catches condensed water which drips off the cooling coil
- _____d. Condensate drain fitting
 - 1) A factory installed short tube soldered into the condensate pan, usually 3/4" I.D. copper for the purpose of connecting the drain pan to a field installed drain line.
 - 2) A trap or anti-siphoning device should be used if the drain is on the suction side of the indoor blower.

TEST

_____ e. Metering devices

- 1) Capillary tube
 - a) Meters refrigerant to the cooling coil by restricting its flow with a miniature valve.
 - b) Is expensive to manufacture.
- 2) Thermostatic expansion valve
 - a) Meters refrigerant to the cooling coil by restricting its flow by a continuous throttling action which is controlled by the super heat setting of the valve.
 - b) Permits reliable operation of the cooling coil over a wider temperature range than is practical with other common types of metering devices.
 - c) May use a distributor to feed the evaporator at more than one point.
- 3) Piston type
 - a) Fixed orifice meters refrigerant to evaporator.
 - b) Capacity changed easily by changing piston.
 - c) Can allow full flow in opposite direction, making them popular for use in heat pumps.

12. Match component problems of low side sections with their probable causes.

- | | | |
|----------|---------------------------|---|
| _____ a. | 1) Insufficient air flow | 1. Frozen coil |
| | 2) Dirty filter | 2. Leak in evaporator coil or return bends |
| | 3) Dirty coil | 3. Coil flooded with oil |
| | 4) Dirty blower wheel | 4. Expansion valve |
| | 5) Undersized ductwork | 5. Refrigerant leaks at refrigerant line fittings |
| | 6) Low refrigerant charge | |

- _____ b.
- 1) Galled threads
 - 2) Compression ferrule on backwards
 - 3) Incomplete make up of connection

TEST

- _____c. 1) Vibration
2) Corrosion
- _____d. 1) Out of adjustment or tolerance
2) Ruptured power element
- _____e. 1) Untrapped refrigerant lines
2) Result of too many compressor changes
13. Arrange in order the steps in using a charging table. Place the correct sequence number in the appropriate blank.
- _____a. Record suction line pressure, ambient temperature, and suction line temperature
- _____b. Suction line temperature reading should be within 3°F of table reading
- _____c. Attach a refrigeration thermometer to the system's suction line where it enters the condensing unit.
- _____d. Attach a suction gauge to the suction line port at the condensing unit
14. Complete statements concerning guidelines for charging a system. Circle the material that best completes each statement.
- a. Use the (manufacturer's recommended) (standard) method for charging.
- b. Having the proper charge is vital to maximum system performance, and the correct charging chart should always be used:
- 1) Manufacturer's charging (chart) (guidelines)
- 2) (Net coil) (Refrigerant) capacity versus percent of correct charge
- 3) (EER) (Btuh) rating versus percent of correct charge
15. Select true statements concerning the scroll compressor. Place an "X" beside each true statement.
- _____a. Compresses gas by interaction of an orbiting spiral and a stationary spiral
- _____b. Has no valves
- _____c. Less efficient than piston type compressor
- _____d. More susceptible to damage due to refrigerant "slugging"

TEST

16. Complete statements concerning evaporative coolers. Circle the material that best completes each statement.
- Evaporative coolers use the principle of (dehumidification) (evaporaticn) to remove sensible heat from air.
 - Early evaporative coolers had problems with cabinets rusting out, erratic water distribution, and build-up from (water chemicals) (contaminants) that could clog a cooler pad or an entire system.
 - Modern evaporative coolers have rust-proof cabinets, a pump to maintain water distribution, and a (bleed-off kit) (drain) to control chemicals in the water supply.
 - The bleed-off kits in modern units are so effective in controlling water chemicals that (filters) (water softeners) are not required.
 - Modern evaporative units have long lasting cooler pads that are inexpensive, long lasting, and easy to (change) (clean).
 - Because they do not expend energy in the actual cooling process, evaporative units are (less) (more) expensive to operate than refrigerated units with compressors.

17. Select true statements concerning evaporative cooling applications. Place an "X" beside each true statement.

(NOTE: For a statement to be true, all parts of the statement must be true.)

- _____ a. Evaporative cooling works best in areas of high humidity, but effective installations have been placed in high humidity areas such as Georgia and Galveston, Texas.
- _____ b. Because evaporative cooling units provide a complete change of air every few minutes, they are popular in schools, factories, churches, and restaurants.
- _____ c. In large, open areas such as stadiums and warehouses, evaporative cooling is about the only form of cooling that can accomplish the job, and do the job economically.
- _____ d. Evaporative cooling units are sometimes used in tandem with refrigerated units:
 - 1) They are used as back-up to the refrigerated system.
 - 2) They are used during the milder part of the cooling season.
 - 3) They are used during start-up to purge a building of stale air during really hot weather.

TEST

- _____e. Newer designs in evaporative coolers feature a two-stage system that cools the air twice to achieve temperatures low enough to compare with comparable refrigerated systems.
18. Solve problems concerning refrigerant recovery and recycling. Select the best solution to each of the following.
- a. Another technician with you on a service call starts to vent refrigerant into the atmosphere. You should what? _____.
- 1) Permit your co-worker to continue.
 - 2) Remind your co-worker that venting refrigerant into the atmosphere helps deplete the earth's protective ozone layer and is also against EPA standards.
 - 3) Advise your co-worker to vent the refrigerant into some kind of container.
- b. A customer sees you using a recovery unit and wants to know if the reclaimed refrigerant can be placed back into the system. You should what? _____.
- 1) Advise the customer that it is only a recovery unit and the refrigerant will be sent away for further processing.
 - 2) Tell the customer it cannot be placed back into the system.
 - 3) Tell the customer you're doing it only to protect the ozone layer.
- c. You've been trained to operate a recovery unit, but on a service call you note the refillable containers on site have no indication that they are approved by the Department of Transportation. You should _____.
- 1) Inform someone with authority that the containers are unsafe and request proper containers before you use the recovery unit.
 - 2) Go ahead with your service call, but be careful.
 - 3) Use the containers but be sure not to fill them more than three-quarters full.

(NOTE: If the following activities have not been accomplished prior to the test, ask your instructor when they should be completed.)

19. Trace the cooling circuit on a single phase package heat/cool unit. (Assignment Sheet #1)
20. Trace the cooling circuit on a 7½ ton three phase rooftop unit. (Assignment Sheet #2)

TEST

21. Demonstrate the ability to:
- a. Troubleshoot an air conditioning condenser section on a "no cooling" complaint. (Job Sheet #1)
 - b. Use a charging table to check the charge in a capillary cooling system. (Job Sheet #2)
 - c. Perform maintenance on an air conditioner. (Job Sheet #3)

**COOLING SYSTEMS
UNIT XIII**

ANSWERS TO TEST

- | | | | | | | | | |
|----|----|----|----|----|----|----|----|----|
| 1. | a. | 7 | f. | 12 | k. | 3 | p. | 17 |
| | b. | 4 | g. | 13 | l. | 2 | q. | 16 |
| | c. | 14 | h. | 11 | m. | 10 | | |
| | d. | 8 | i. | 9 | n. | 6 | | |
| | e. | 15 | j. | 5 | o. | 1 | | |

2. Order may vary:

- d. Metering device
- e. Evaporator
- f. Condenser

3. Order may vary:

- e. Suction line accumulator
- d. Receiver

- | | | | | | | |
|----|----|----|----|----|----|----|
| 4. | a. | 7 | f. | 11 | k. | 9 |
| | b. | 5 | g. | 1 | l. | 6 |
| | c. | 14 | h. | 10 | m. | 8 |
| | d. | 12 | i. | 3 | n. | 4 |
| | e. | 2 | j. | 13 | o. | 15 |

- 5.
- a. 3 or 2
 - b. 4
 - c. 1
 - d. 2 or 3

6. a, b, c

- 7.
- a. 2
 - b. 3
 - c. 1

- | | | | | |
|----|----|---|----|---|
| 8. | a. | 4 | c. | 2 |
| | b. | 1 | d. | 3 |

- | | | | | |
|----|----|---|----|---|
| 9. | a. | 2 | c. | 2 |
| | b. | 3 | d. | 1 |

ANSWERS TO TEST

10. a. 2 d. 3 g. 7
 b. 1 e. 6
 c. 4 f. 5
11. a, b, c, d
12. a. 1 d. 4
 b. 5 e. 3
 c. 2
13. a. 3 c. 1
 b. 4 d. 2
14. a. Manufacturer's recommended
 b. 1) Chart
 2) Net coil
 3) EER
15. a, b
16. a. Evaporation
 b. Water chemicals
 c. Bleed-off kit
 d. Water softeners
 e. Change
 f. Less
17. b, c, d, e
18. a. 2
 b. 1
 c. 1
19. Evaluated according to assignment sheet answers
20. Evaluated according to assignment sheet answers
21. a. Evaluated according to criteria in Practical Test #1
 b. Evaluated according to criteria in Practical Test #2
 c. Evaluated according to criteria in Practical Test #3



HEAT PUMP SYSTEMS UNIT XIV

UNIT OBJECTIVE

After completion of this unit, the student should be able to identify heat pump configurations and troubleshoot a variety of heat pump complaints. These competencies will be demonstrated by completing the assignment and job sheets, and by scoring a minimum of 85 percent on the unit test.

SPECIFIC OBJECTIVES

After completion of this unit, the student should be able to:

1. Match terms related to heat pump systems with their definitions.
2. Identify heat pump configurations.
3. Identify components of a heat pump.
4. Identify components of a 4-way reversing valve.
5. Differentiate between the operation of a 4-way reversing valve in the heating and cooling modes.
6. Select true statements concerning metering devices and check valves.
7. Select true statements concerning a heat pump in the defrost mode.
8. Select true statements concerning methods of defrost initiation and termination.
9. Identify components of a heat pump indoor section.
10. Complete a list of component failures of heat pumps.
11. Solve problems concerning the heat pump touch test.
12. Solve problems concerning special precautions for replacing reversing valves.
13. Complete statements concerning special precautions for driers.
14. Select true statements concerning general guidelines for supplemental heating strips.
15. Select true statements concerning temperature controls.

OBJECTIVE SHEET

16. Select true statements concerning fossil fuel/add-on heat pumps.
17. Solve problems concerning water source heat pumps.
18. Complete statements concerning closed-loop/ground-source heat pumps.
19. Complete statements concerning rules for good heat pump operation.
20. Trace operational circuits for a heat pump in the cooling mode. (Assignment Sheet #1)
21. Trace operational circuits for first stage heating in a heat pump. (Assignment Sheet #2)
22. Trace operational circuits for a heat pump in the defrost mode. (Assignment Sheet #3)
23. Trace operational circuits for second stage supplemental heat in a heat pump. (Assignment Sheet #4)
24. Trace operational circuits for a fossil fuel heat pump system in first stage heat mode above 45°F outdoor ambient. (Assignment Sheet #5)
25. Trace operational circuits for a fossil fuel heat pump system in first stage heat mode below 40°F outdoor ambient. (Assignment Sheet #6)
26. Demonstrate the ability to:
 - a. Wire a control system for a heat pump. (Job Sheet #1)
 - b. Troubleshoot a heat pump indoor section in the cooling mode. (Job Sheet #2)
 - c. Perform maintenance on an indoor section of heat pump in the cooling mode. (Job Sheet #3)
 - d. Troubleshoot a heat pump on a "no cooling" complaint. (Job Sheet #4)
 - e. Troubleshoot a heat pump outdoor section on an "insufficient cooling" complaint. (Job Sheet #5)
 - f. Perform maintenance on the indoor section of a heat pump. (Job Sheet #6)
 - g. Troubleshoot supplemental heat on a heat pump. (Job Sheet #7)
 - h. Perform maintenance on heat pump supplemental heating. (Job Sheet #8)
 - i. Troubleshoot a heat pump on a "no heat" complaint when the compressor will not run. (Job Sheet #9)

OBJECTIVE SHEET

- j. Troubleshoot a heat pump on a "no heat" complaint when the compressor runs but cycles on compressor overload. (Job Sheet #10)
- k. Troubleshoot a heat pump on an "insufficient heat" complaint when the compressor will run. (Job Sheet #11)
- l. Check operation of an Essex solid state time-temperature defrost control. (Job Sheet #12)
- m. Check operation of a Ranco E-15 mechanical time-temperature defrost control. (Job Sheet #13)
- n. Check operation of an Essex 149-600 solid state demand defrost control. (Job Sheet #14)

HEAT PUMP SYSTEMS UNIT XIV

SUGGESTED ACTIVITIES

- A. Obtain additional materials and/or invite resource people to class to supplement/reinforce information provided in this unit of instruction.

(NOTE: This activity should be completed prior to the teaching of this unit.)

- B. Make transparencies from the transparency masters included with this unit.
- C. Provide students with objective sheet.
- D. Discuss unit and specific objectives.
- E. Provide students with information and assignment sheets.
- F. Discuss information and assignment sheets.

(NOTE: Use the transparencies as needed to enhance the information.)

- G. Provide students with job sheets.
- H. Discuss and demonstrate the procedures outlined in the job sheets.
- I. Integrate the following activities throughout the teaching of this unit:
1. Invite a homeowner with a heat pump system to talk with the class concerning initial costs, operational costs, and benefits or problems experienced.
 2. Invite a manufacturer's representative to talk with the class concerning improvements in heat pump design and performance.
 3. Arrange a field trip to see a heat pump system being installed in a residential or light commercial application. Arrange to see a closed loop ground source installation if possible.
 4. Meet individually with students to evaluate their progress through this unit of instruction, and indicate to them possible areas for improvement.
- J. Give test.
- K. Evaluate test.
- L. Reteach if necessary.

SUGGESTED ACTIVITIES

REFERENCES USED IN DEVELOPING THIS UNIT

- A. *Heat Pump Design, Service, and Application*. Dallas, TX 75240: Education Department, Lennox Industries, Inc., 1979.
- B. Althouse, Andrew D., and Carl H. Turnquist and Alfred F. Bracciano. *Modern Refrigeration and Air Conditioning*. South Holland, IL: The Goodheart-Willcox Company, Inc., 1988.
- C. Eckes, William, and Dan Fulkerson. *Air Conditioning and Refrigeration, Book Four*. Stillwater, OK 74074: Mid-America Vocational Curriculum Consortium, 1981.
- D. *Heat Pump Installation and Service*. Lavergne, TN 37086: Heil-Quaker Training Center, 1987.
- E. *Heat Pump Training Manual*. Fort Smith, AR 72906: Rudd Air Conditioning Division, n.d.
- F. *Closed-Loop/Ground-Source Heat Pump Systems Installation Guide*. Stillwater, OK 74078: Oklahoma State University, 1988.

HEAT PUMP SYSTEMS XIV

INFORMATION SHEET

I. Terms and definitions

- A. **Heat pump** — A refrigerated air conditioning system with a valve to reverse the action or direction of heat transfers
- B. **Reversing valve** — A valve used to reverse the action or direction of heat transfers by routing refrigerant
- C. **Check valve** — Allows refrigerant to flow in one direction
- D. **Defrost cycle** — A cycle used to melt frost accumulation from the outside coil
- E. **Fossil fuel/add on heat pump** — A heat pump operated with a fossil fuel furnace
- F. **Water source heat pump** — Uses water or other liquid as the heat exchanger medium
- G. **Bi-directional flow drier** — A drier designed to work with flow in either direction
- H. **Ground loop** — A sealed and pressurized loop of water or anti-freeze solution circulated below the earth's surface
- I. **Supplemental heat** — Usually electric strip heaters to add heat when the unit cannot maintain the indoor temperature desired
- J. **Flow switch** — Monitors liquid flow and shuts down system when there is no liquid flow
- K. **Freeze thermostat** — Monitors water temperature and shuts down unit operation if water temperature gets too low
- L. **Low ambient switch** — Monitors outdoor temperature to de-activate a heat pump and switch to alternate heating when temperature goes below a given set point
- M. **Plenum switch** — Monitors air temperature in the supply plenum in order to control activation of the furnace or heat pump in fossil fuel/heat pump add-on systems

II. Heat pump configurations

- A. Heat pump configurations are described according to their inputs and outputs.
- B. An **Air-to-Air Heat Pump** extracts heat from a cold air source and delivers heat to a warm air sink. (Figure 1)

INFORMATION SHEET

FIGURE 1

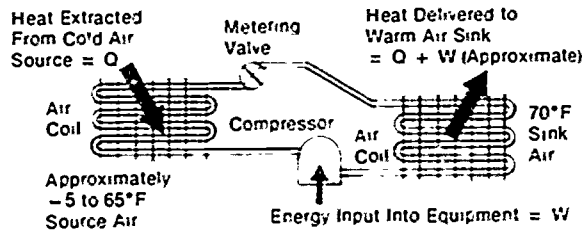

Courtesy Air Conditioning Contractors of America

- C. A **Water-to-Air Heat Pump** extracts heat from a cold water source and delivers heat to a warm air sink. (Figure 2)

FIGURE 2

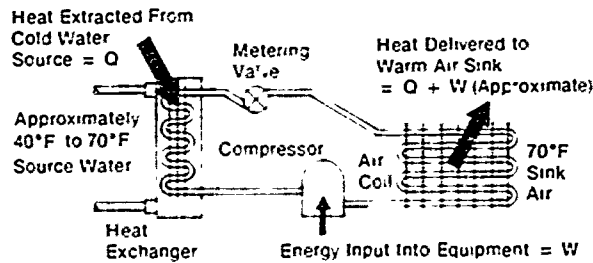

Courtesy Air Conditioning Contractors of America

- D. An **Air-to-Water Heat Pump** extracts heat from a cold air source and delivers heat to a warm water sink. (Figure 3)

FIGURE 3

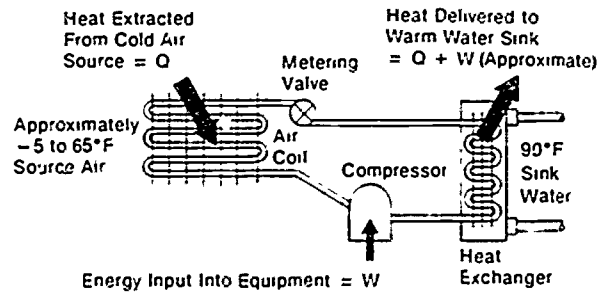

Courtesy Air Conditioning Contractors of America

INFORMATION SHEET

- E. A **Water-to-Water Heat Pump** extracts from a cold water source and delivers heat to a warm water sink. (Figure 4)

FIGURE 4

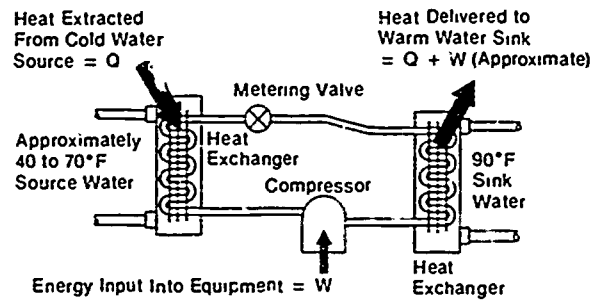

Courtesy Air Conditioning Contractors of America

III. Components of a heat pump (Transparency 1)

- A. Indoor and outdoor refrigerant coils
- B. Compressor
 1. Heat pump compressor is different from a "cooling duty" type compressor
 2. Should not be replaced by "cooling duty" type compressor
- C. Indoor and outdoor metering devices
 1. Capillary tube
 2. Thermostatic expansion valve
 3. Piston type
- D. Indoor and outdoor check valves
 1. Used to bypass metering device when it is not needed
 2. Not necessary when piston type metering device is used since it bypasses automatically when refrigerant flow is reversed
- E. Reversing valve
- F. Crankcase heater
- G. Suction accumulator

INFORMATION SHEET

- H. Indoor blower
- I. Outdoor fan

IV. Components of a 4-way reversing valve (Transparency 2)

- A. Connection to discharge line of compressor
- B. Connection to suction line of compressor
- C. Connection to outside coil
- D. Connection to inside coil
- E. Piston
- F. Solenoid and activating device
- G. Piston bleed ports

V. Operation of a reversing valve (Transparency 3)

- A. Routes discharge gas to the outdoor coil in the cooling mode
- B. Routes discharge gas to the indoor coil in the heating mode
- C. Accomplished by energizing or de-energizing the solenoid coil on the pilot valve
 - 1. Piston moved by differential of pressure at the ends of the piston
 - 2. Solenoid valve coils may be 24 or 240 volt operated

VI. Metering devices and check valves

- A. A heat pump system with thermostatic expansion valve or capillary metering devices must have a check valve for each metering device. (Transparency 4)
- B. In the cooling mode, an indoor check valve is closed and refrigerant flow is through the metering device while the outdoor check valve is open and the refrigerant bypasses the outdoor metering device.

(NOTE: The refrigerant will take the path of least resistance.)

- C. In the heating mode, the indoor check valve opens bypassing the indoor metering device, and the outdoor check valve closes causing refrigerant to flow through the outdoor metering device.

INFORMATION SHEET

- D. In heating the outdoor coil is then the heat absorbing coil and the indoor coil is the heat dissipating coil.

(NOTE: Configuration varies with manufacturer.)

- E. A heat pump with a flow check piston metering device is similar to a typical split-system air conditioner when the heat pump is in the cooling mode. (Transparency 5)

(NOTE: The additional components for the reverse cycle are the only differences.)

- F. In the heating mode, a heat pump with flow check piston metering is like a typical split-system air conditioner except that the reversing valve has changed direction of refrigerant flow.
- G. When the flow type check piston metering is used, there are no separate check valves in the refrigerant circuit.

VII. Operation of a heat pump in the defrost mode (Transparency 6)

- A. The defrost cycle is initiated by "time/temperature" or "demand" depending on the method.
- B. The reversing valve operates and goes into a cooling cycle.
- C. Hot discharge gas from the compressor is routed to the outdoor coil.
- D. Frost accumulation on the outdoor coil is melted.
- E. The outside fan is de-energized to assist the melting process.

(NOTE: If the outdoor unit is exposed to prevailing winds, the system may experience difficulty in the defrost mode because of a wind chill factor.)

- F. Some supplementary heat is energized to temper the cool air across the indoor coil during defrost.
- G. After frost removal has been accomplished the cycle is terminated by the method used by the manufacturer.
- H. The reversing valve changes flow back to the heating cycle and the outdoor fan is energized.

INFORMATION SHEET**VIII. Methods of defrost initiation and termination**

(NOTE: Methods of defrost initiation and termination vary by manufacturer. The most common are usually "time and temperature" operated.)

- A. Time/temperature mechanical (Ranco E-15 system)
 - 1. Initiates at preset time interval if coil temperature is below the "make point" of the sensing bulb
 - 2. Terminates when coil temperature reaches the "break point"
 - 3. Some controls have a maximum defrost time of 10 minutes and will automatically switch back to heating cycle
 - 4. Some units may use pressure switch instead of temperature sensing bulb.
 - 5. Time intervals can be selected as local conditions require.
- B. Time/temperature, solid state (Essex board system)
 - 1. Solid state board used as the timing device
 - 2. Bi-metal sensing device
 - 3. Time intervals can be selected as local conditions require.
- C. Demand defrost, solid state
 - 1. Solid state control board
 - 2. Coil sensor
 - 3. Ambient air sensor
- D. Demand defrost, air switch/temperature
 - 1. Air pressure sensing tubes mounted to sense air pressure drop across the outdoor coil
 - 2. Diaphragm operated micro-switch puts unit into defrost if frost or ice creates enough air pressure drop across the coil and the temperature sensing device is closed

IX. Components of a heat pump indoor section (Transparency 7)

- A. Cabinet
- B. Filter and return air inlet

INFORMATION SHEET

- C. Heating elements
- D. Blower assembly
- E. Blower and limit control switches
- F. Supply outlet
- G. Indoor coil
- H. Controls for supplementary heat and indoor blower motor

X. Component failures of heat pumps

(NOTE: Common cooling unit component failures apply to heat pumps.)

- A. Check valve
 - 1. May stick in the open position
 - 2. May stick in the closed position
 - 3. May stick in a partially open position and restrict refrigerant flow
- B. Reversing valve
 - 1. Holding coil for solenoid may be open or shorted
 - 2. Piston may not shift position

(NOTE: A stuck piston can be quickly detected by using the touch test outlined in the next objective.)

XI. The heat pump touch test

- A. The touch test is a quick way to spot a problem with a reversing valve.
- B. After a few minutes operation in the heating mode, the compressor discharge line into the reversing valve and the line out of the valve into the indoor coil should both feel hot. (Figure 5)
- C. After a few minutes operation in the heating mode, the line from the outdoor coil into the valve and the line from the valve to compressor suction should both feel cool. (Figure 5)

INFORMATION SHEET

FIGURE 5

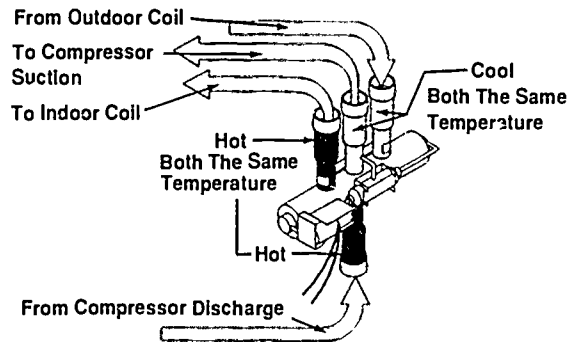

Courtesy Inter-City Products Corporation (USA)

- D. After a few minutes operation in the cooling cycle, the line from compressor discharge into the valve and the line from the valve to the outdoor coil should both feel hot. (Figure 6)
- E. After a few minutes operation in the cooling mode, the line from the indoor coil into the valve and the line out of the valve to the compressor section should both feel cool. (Figure 6)

FIGURE 6

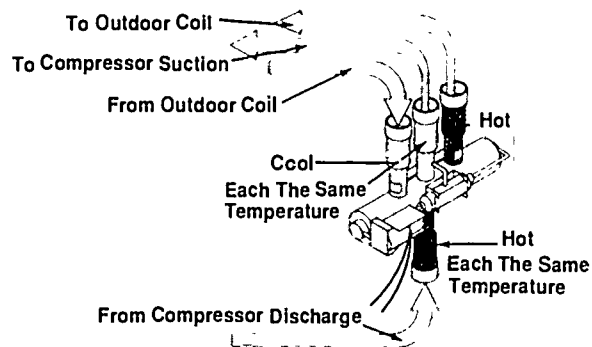

Courtesy Inter-City Products Corporation (USA)

- F. After a few minutes of operation in either mode, if all three tubes on the suction side of a reversing valve are hot, it means the piston is stuck in mid-position. (Figure 7)

INFORMATION SHEET

FIGURE 7

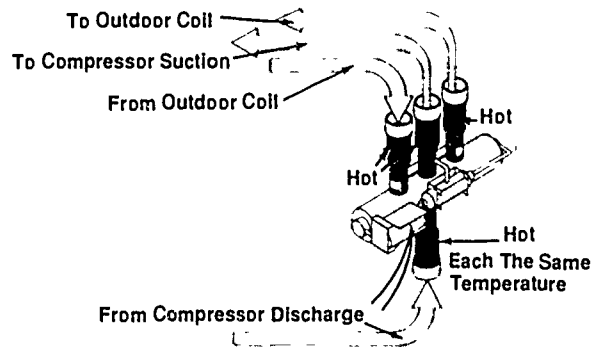

Courtesy Inter-City Products Corporation (USA)

XII. Special precautions for replacing reversing valves

- A. Make sure replacement is positioned the same as the one removed.

(NOTE: Not all manufacturers energize the solenoid in the same mode and care must be taken to not have the operation reversed.)

- B. Never expose a reversing valve to excessive heat.

(NOTE: Using silver solder and flux when brazing will help control heat, but the valve should still be wrapped with a wet cloth or a heat sink should be used, and the flame should always be directed away from the valve.)

- C. Keep the inside free of all foreign material.

(NOTE: Flux, dirt, or even moisture may impair operation and contribute to premature failure.)

- D. Never strike a reversing valve with any tool that could dent or bend any part of the valve.

- E. Install in a location that will help keep vibration from the compressor to a minimum.

- F. Pilot valve should not be on the bottom.

XII. Special precautions for driers

- A. A suction drier MUST be located between the compressor and the reversing valve.

- B. A bi-directional flow liquid line drier must be used if installed where liquid flow is reversed.

INFORMATION SHEET**XIV. Guidelines for supplemental heating strips**

- A. Usually installed in the indoor section
- B. Should always be installed on the discharge side of the air handling equipment, downstream from the indoor coil
- C. Controls for strip heaters must be readily accessible
- D. Duct heater may be used if necessary (Transparency 8)

XV. Temperature controls

- A. Room thermostat
 - 1. Usually two stage heating and single stage cooling
 - 2. Must be compatible with the heat pump control circuitry
 - 3. Usually equipped with "emergency heat" switch to put operation totally on supplemental form of heat
- B. Outdoor thermostat
 - 1. Senses outdoor ambient temperature
 - 2. May be used to restrict or stage supplemental heaters

XVI. Fossil fuel/add-on heat pumps

- A. Heat pump used at milder temperatures
- B. Furnace used at lower temperatures
- C. Heat pump uses fossil fuel furnace for indoor air handler
 - 1. Indoor coil usually on downstream side of heat exchanger
 - 2. Heat pump turned "off" when the furnace heat is "on"
 - 3. Plenum switch may be used to operate the furnace during defrost by monitoring air temperature in the duct

XVII. Water source heat pumps

- A. Work similar to air-to-air heat pumps
 - 1. Instead of air, water or another liquid is used as the heat exchanger medium.
 - 2. System does not need an outdoor fan.

INFORMATION SHEET

3. No defrost cycle is necessary.
- B. Open-loop system makes direct use of well water or pond or lake water.
- C. Closed-loop system liquid circulates through a loop in the ground.
- D. System may include a flow switch and a freeze thermostat

XVIII. Closed-loop/ground-source heat pumps

- A. Systems absorb heat from the earth during the heating cycle. (Transparency 9)
- B. Systems reject heat into the earth during the cooling cycle. (Transparency 10)
- C. System configuration can be horizontal or vertical depending on available land. (Transparency 11)
- D. System requires contacting utility companies before drilling or trenching.

(NOTE: Before attempting to plan or install a closed-loop/ground-source heat pump, it is highly recommended that interested parties attend a planning and installation workshop.)

XIX. Rules for good heat pump operation

- A. Proper air flow to include:
 1. Correct duct design
 2. Keeping filters clean
 3. Keeping coils clean
- B. System must have proper refrigerant charge.

Components of a Heat Pump

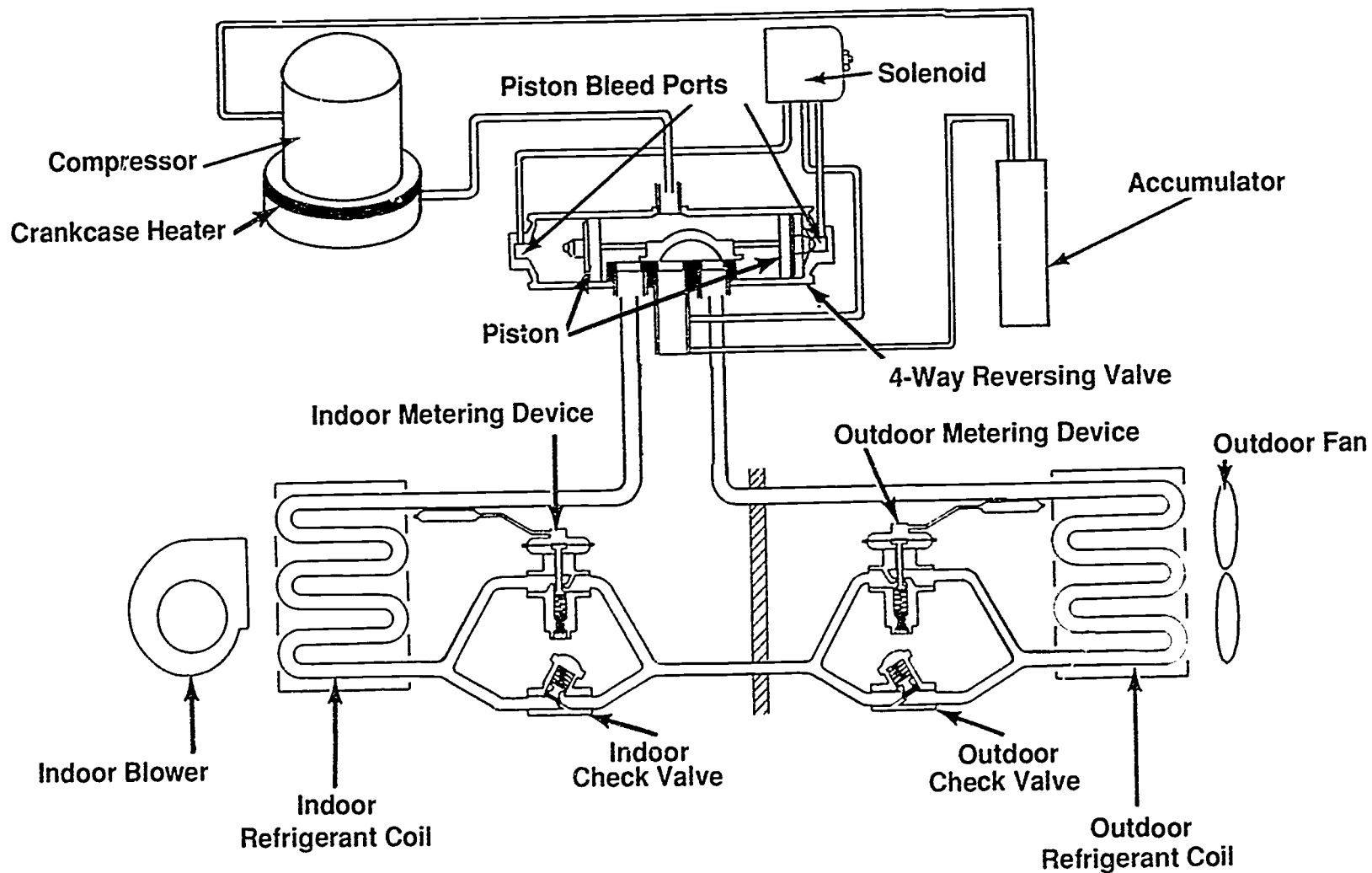

Components of a 4-Way Reversing Valve

Cooling Mode

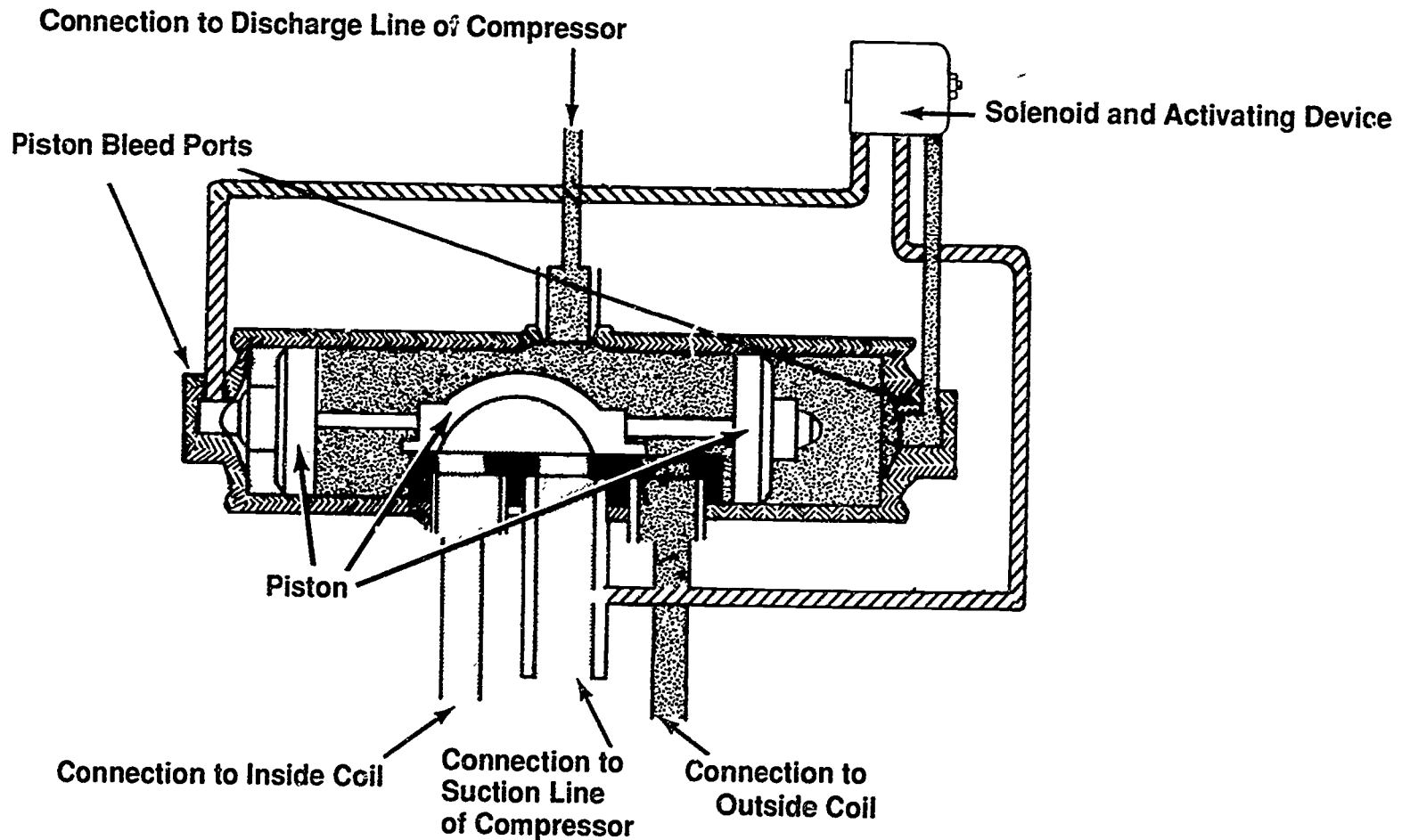

Operation of a 4-Way Reversing Valve

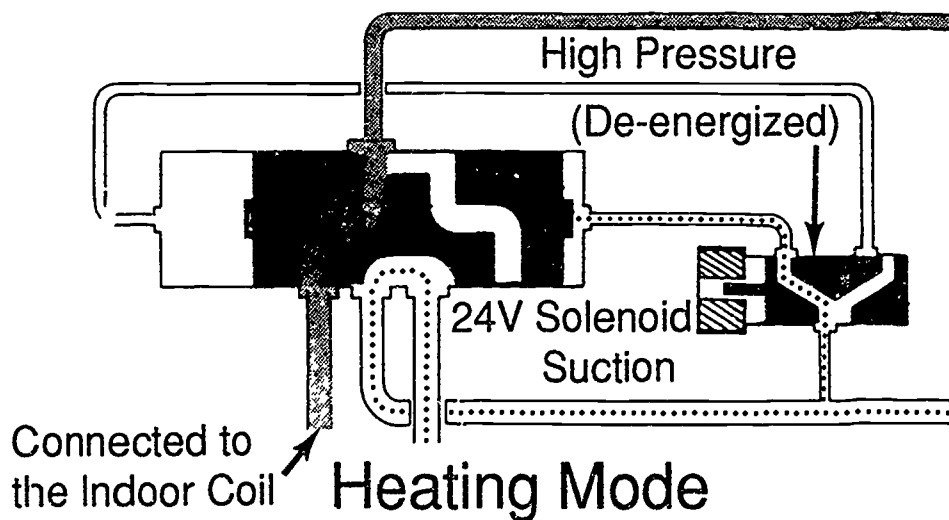
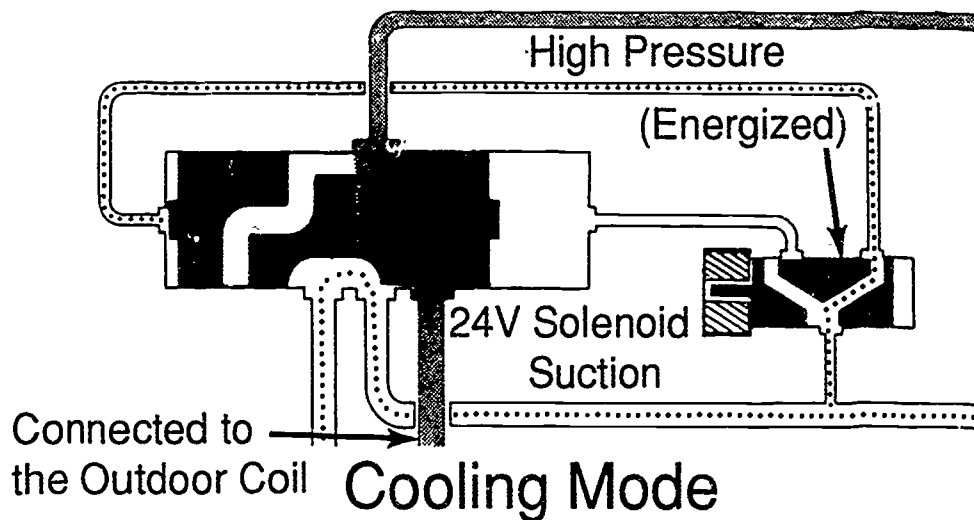

Courtesy Lennox Industries Inc.

Indoor and Outdoor Check Valves

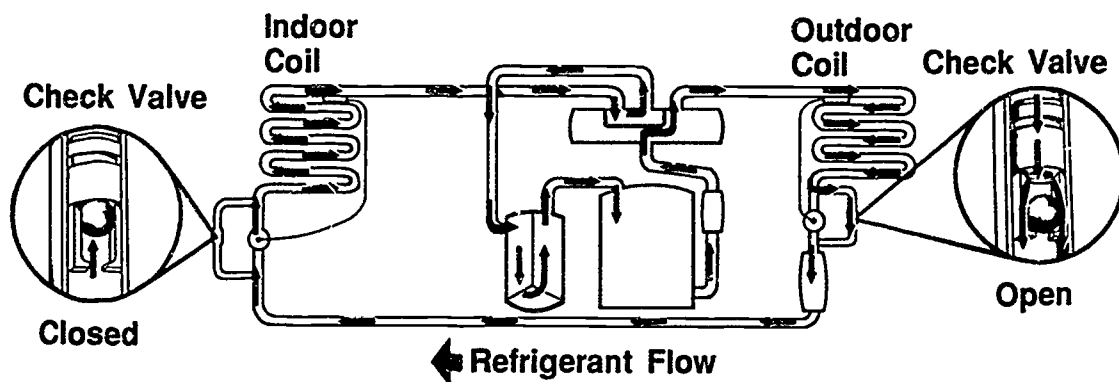

Cooling Mode

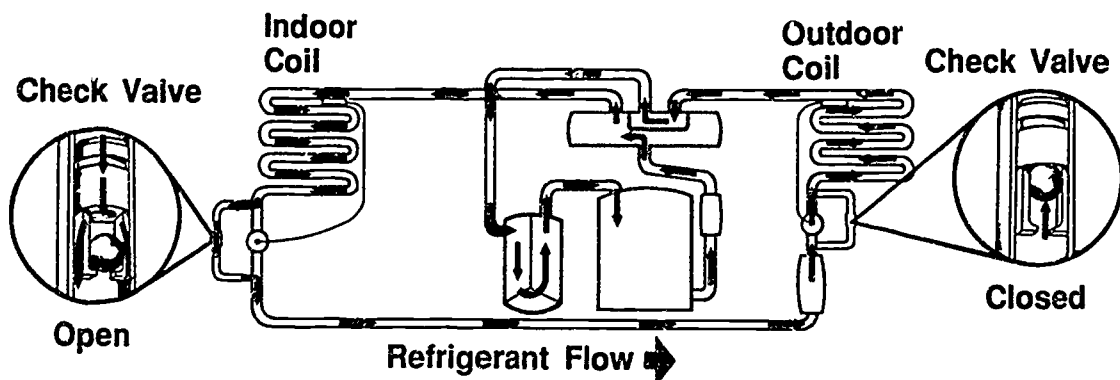

Heat Mode

Courtesy Rheem Manufacturing Company

Piston Metering Devices

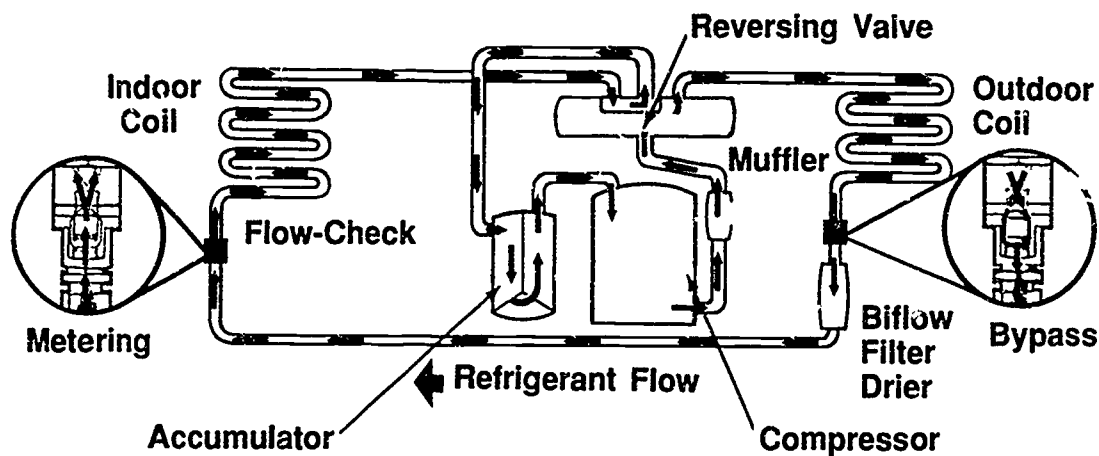

Cooling Mode

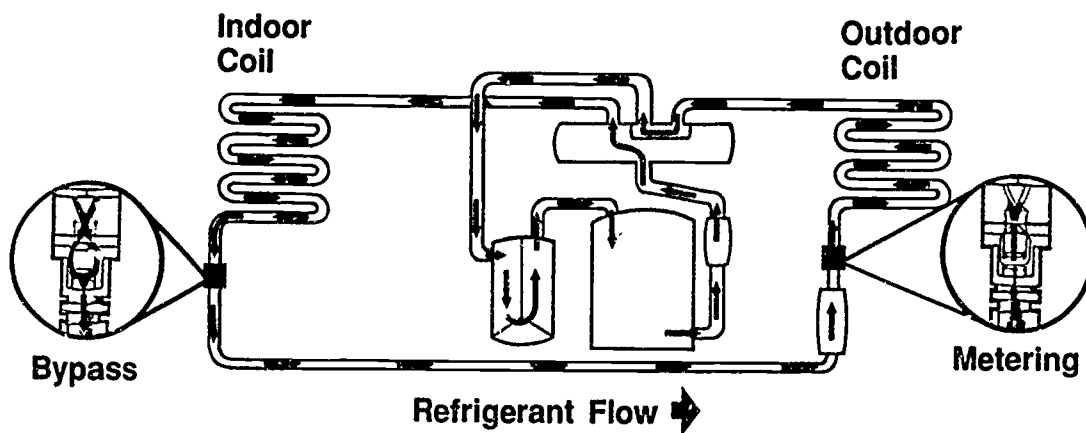

Heat Mode

Courtesy Rheem Manufacturing Company

Heat Pump in Defrost Mode

Thermostat Calls For Heating

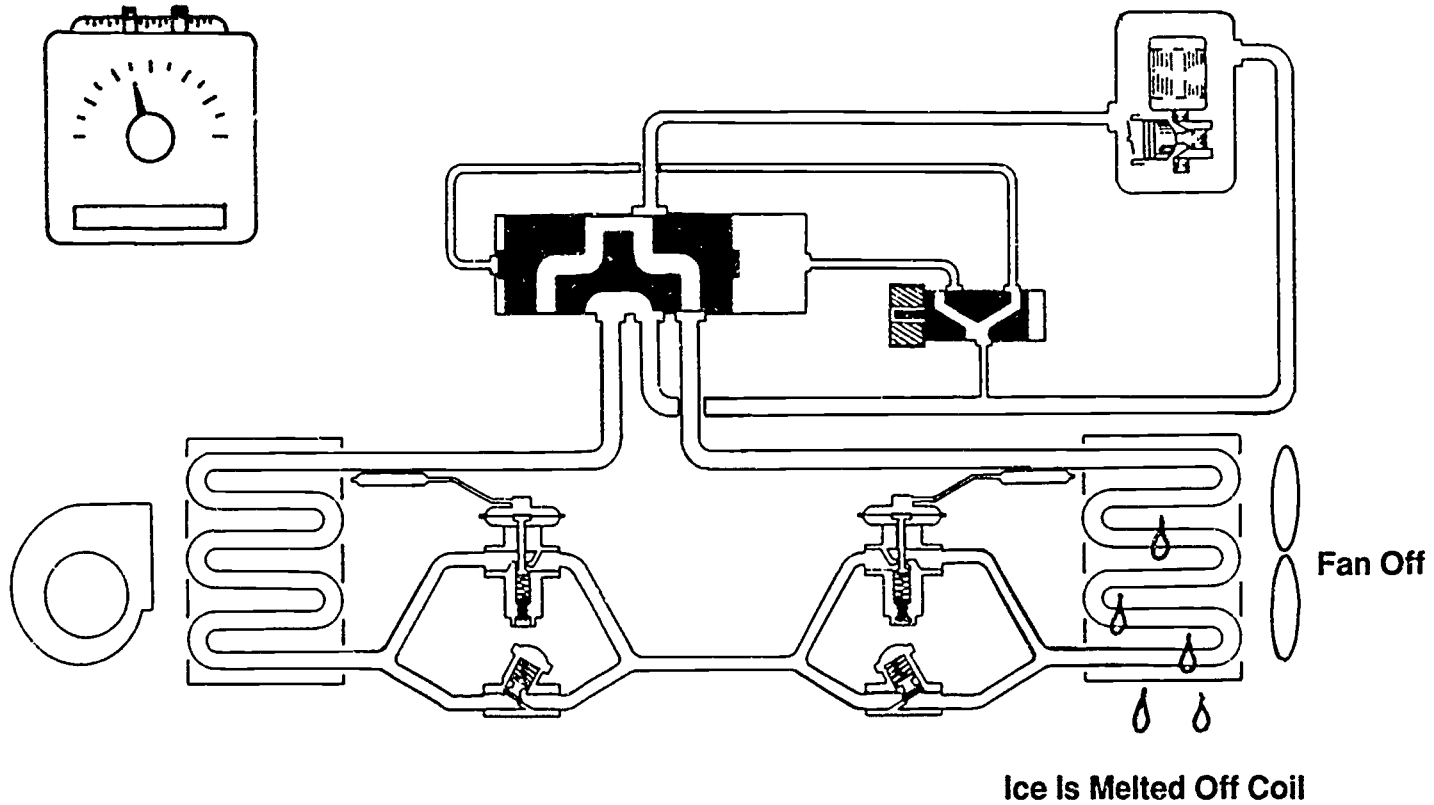

Courtesy Lennox Industries Inc.

690

691

Components of a Heat Pump Indoor Section

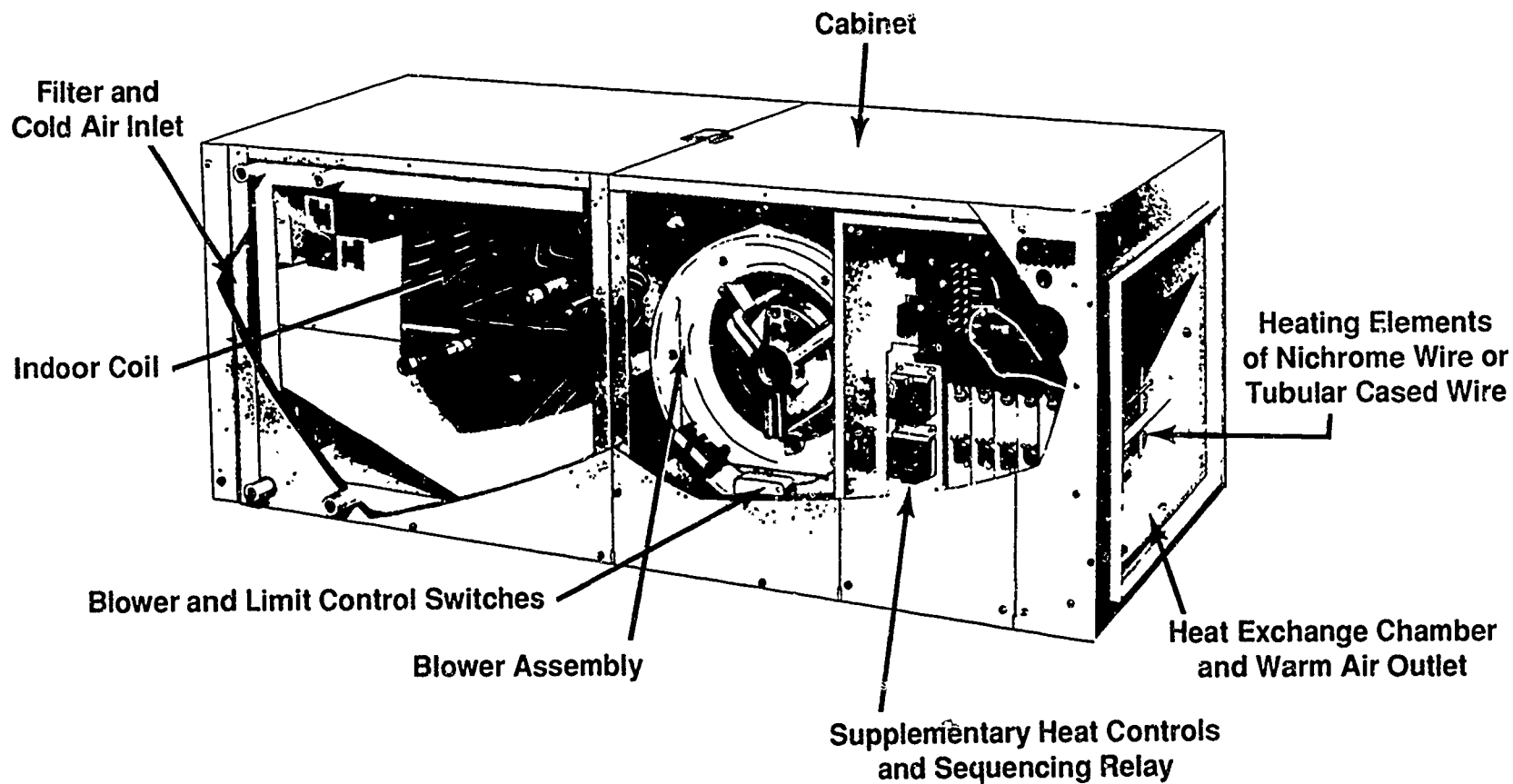

Courtesy Lennox Industries Inc.

Supplemental Electric Heat and Typical Installation

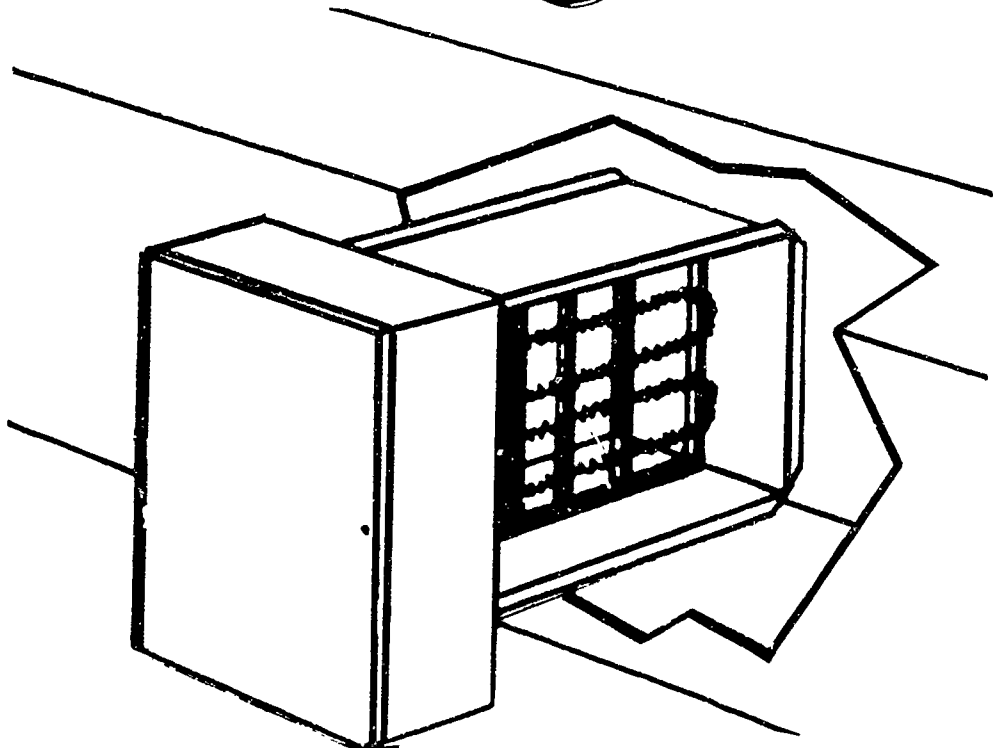
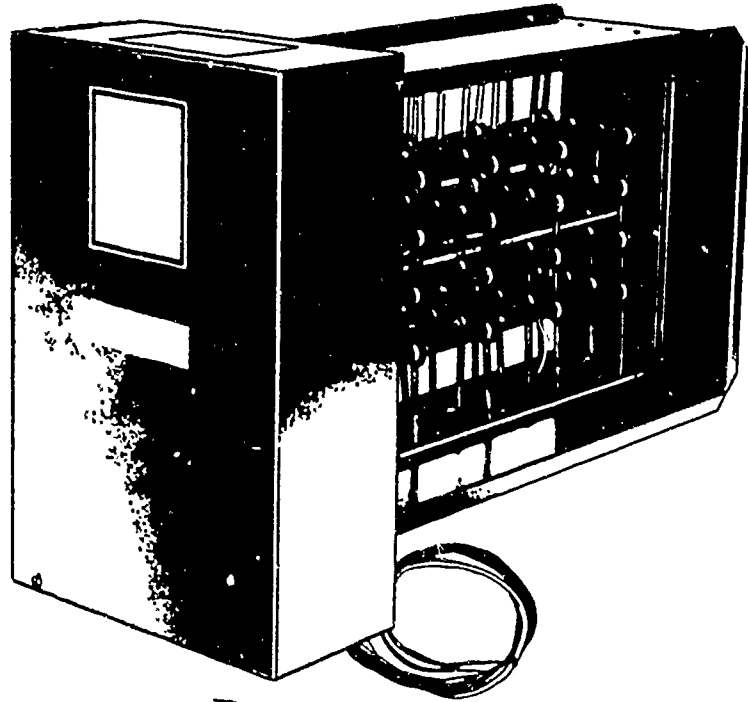

Courtesy Lennox Industries Inc.

Closed-Loop/Ground-Source Heat Pump in Heating Mode

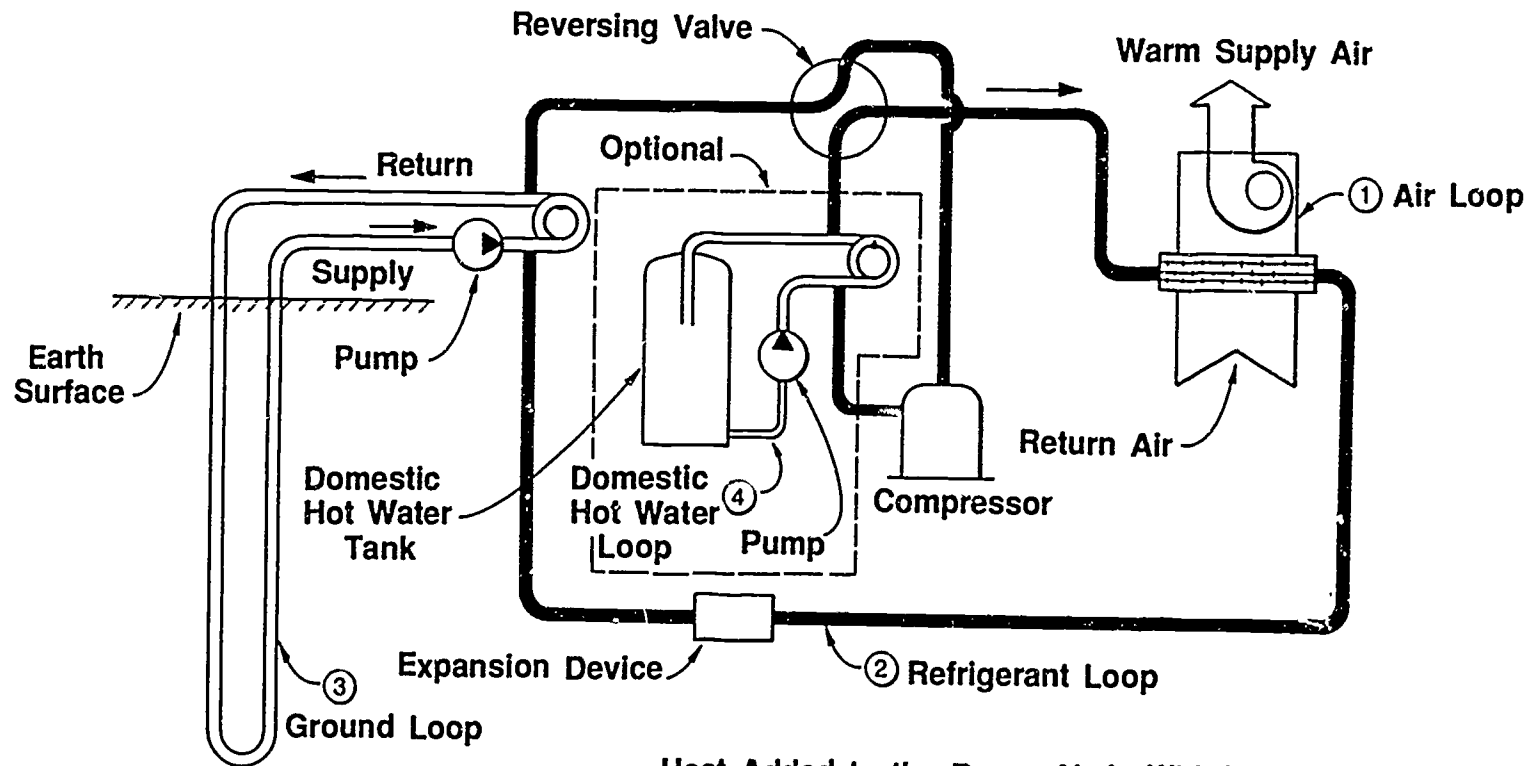

Heat Added to the Room Air is Withdrawn from the Circulating Fluid in the Ground Loop

Courtesy International Ground Source Heat Pump Association

Closed/Loop/Ground Source Heat Pump in Cooling Mode

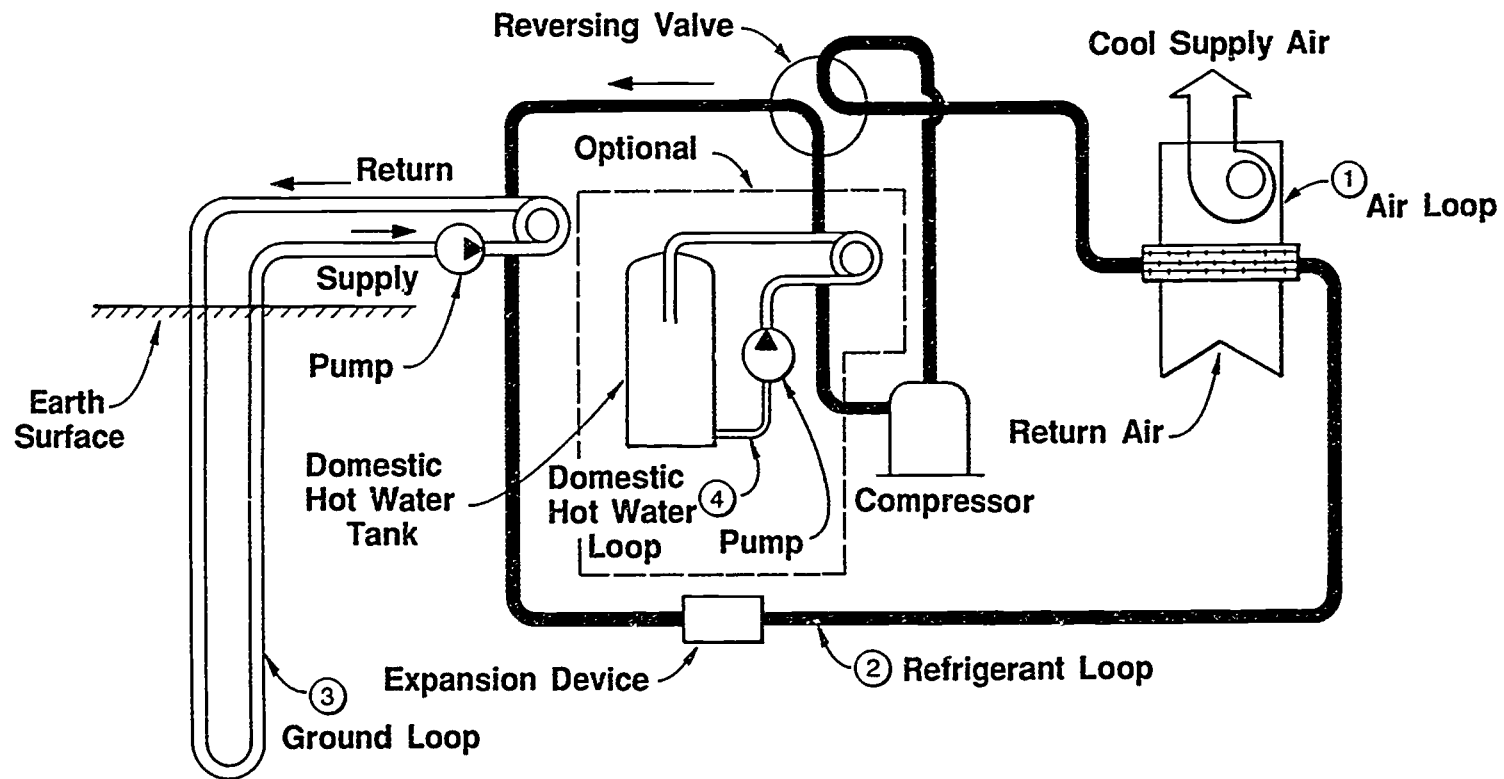

Courtesy International Ground Source Heat Pump Association

Closed-Loop/Ground-Source Heat Pump Installations

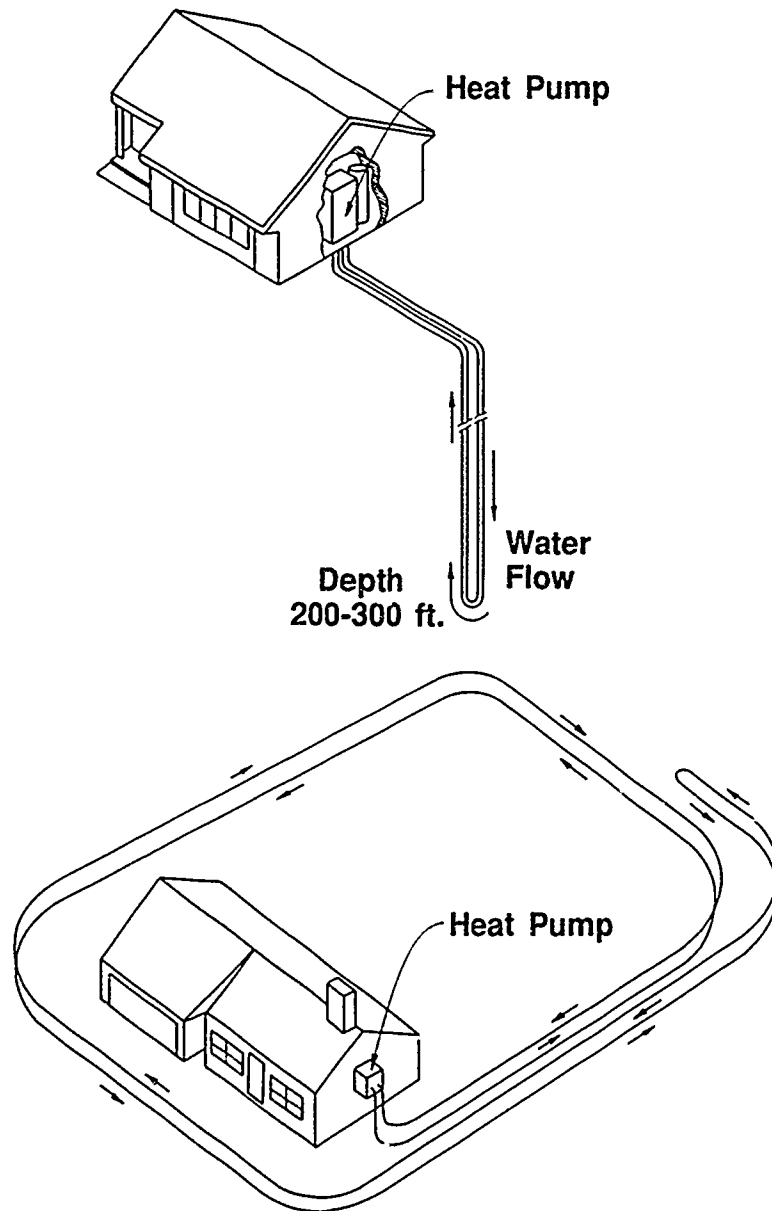

Courtesy International Ground Source Heat Pump Association

HEAT PUMP SYSTEMS UNIT XIV

HANDOUT #1 — CLOSED-LOOP/GROUND-SOURCE (CL/GS) HEAT PUMPS

Purpose

The closed-loop/ground source heat pump system uses solar energy stored beneath the surface of the earth. Using the earth as a heating and cooling sink is possible because soil temperature is more moderate year round than the outside air. A brief explanation of the CL/GS system will help an HVAC technician better appreciate heat pumps in general.

System components

A typical CL/GS system consists of a closed-loop buried pipe, a water-source (water-to-air) heat pump, and an air distribution system for directing heated or cooled air to specific locations in a building. In some units, an extra heat exchanger or desuperheater is added to provide domestic hot water.

System dynamics

When we talk about annual average air temperature, we know it means averaging what might be an extreme temperature swing. For instance, in Stillwater, Oklahoma, an extreme winter temperature of -5°F and an extreme summer temperature of 105°F give an annual average air temperature of 59.2°F . Because of the earth's own insulation, soil temperature is more moderate year round than is the outside air. This means that in Stillwater, Oklahoma, where the average annual temperature is 59.2°F , temperatures at a depth of five feet range from 49°F in mid-February to 74°F in Mid-August. The underground temperature swing is significantly less than the outside air temperature swing, and the natural conditions of the earth's crust and solar energy set up a situation where the CL/GS system can be extremely effective.

Conclusion

installing a CL/GS system requires careful planning. Persons interested in such systems are encouraged to attend a workshop before attempting to plan or install a system. Information about the systems is available from the International Ground Source Heat Pump Association at P.O. Box 1688, Stillwater, OK 74074-1688. In areas where the annual outdoor temperature swing is high, the CL/GS system functions well. Examining local climate information and geography is a good place to start in evaluating whether a CL/GS system will do the best job for a given area.

HEAT PUMP SYSTEMS UNIT XIV

ASSIGNMENT SHEET #1 — TRACE OPERATIONAL CIRCUITS FOR A HEAT PUMP IN THE COOLING MODE SCHEMATIC DIAGRAM

Legend-Equipment Diagram

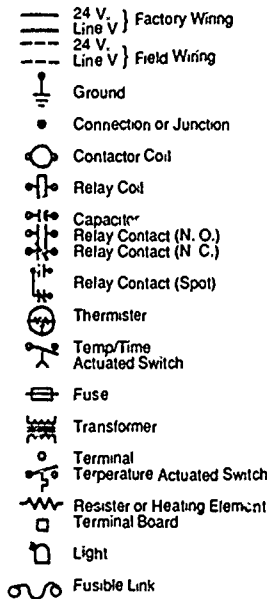

- | | |
|------|---------------------------------|
| CA | Cooling Anticipator |
| CF | Fan Capacitor |
| CN | Wire Connector |
| CPR | Compressor |
| CR | Run Capacitor |
| CS | Start Capacitor |
| CSR | Start Relay |
| D | Defrost Relay |
| DFT | Defrost Timer |
| DT | Defrost Termination Switch |
| F | Indoor Fan Relay |
| FTB | Fan Terminal Board |
| FU | Fuse |
| HA | Heat Anticipator |
| HVTB | High Voltage Terminal Board |
| IOL | Internal Overload Protector |
| LT | Light |
| LVTB | Low Voltage Terminal Board |
| MS | Compressor Contactor |
| ODA | Outdoor Temperature Anticipator |
| ODF | Outdoor Fan Relay |
| ODS | Outdoor Temperature Sensor |
| ODT | Outdoor Thermostat |
| RHS | Resistance Heat Switch |
| SC | Switchover Valve Solenoid |
| SM | System "On-Off" Switch |
| TDL | Discharge Line Thermostat |
| TNS | Transformer |
| TSC | Cooling Thermostat |
| TSH | Heating Thermostat |

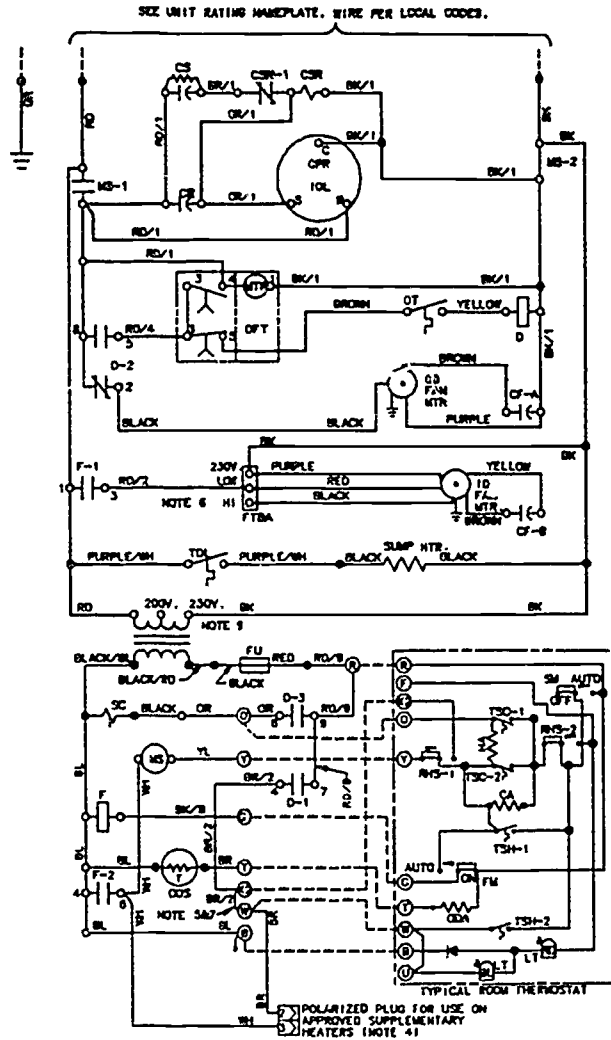

Schematic from service literature provided by the Trane Company, a division of American Standard Inc.

HEAT PUMP SYSTEMS UNIT XIV

ASSIGNMENT SHEET #2 — TRACE OPERATIONAL CIRCUITS FOR FIRST STAGE HEATING IN A HEAT PUMP

SCHEMATIC DIAGRAM

Legend-Equipment Diagram

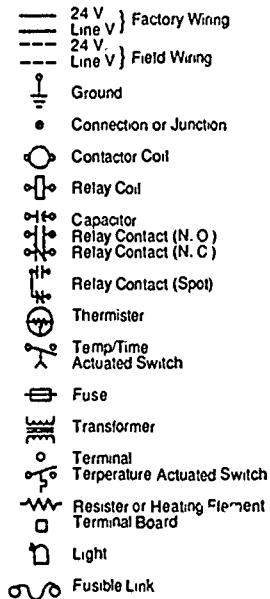

- | | |
|------|---------------------------------|
| CA | Cooling Anticipator |
| CF | Fan Capacitor |
| CN | Wire Connector |
| CPR | Compressor |
| CR | Run Capacitor |
| CS | Start Capacitor |
| CSR | Start Relay |
| D | Defrost Relay |
| DFT | Defrost Timer |
| DT | Defrost Termination Switch |
| F | Indoor Fan Relay |
| FTB | Fan Terminal Board |
| FU | Fuse |
| HA | Heat Anticipator |
| HVTB | High Voltage Terminal Board |
| IOL | Internal Overload Protector |
| LT | Light |
| LVTB | Low Voltage Terminal Board |
| MS | Compressor Contactor |
| ODA | Outdoor Temperature Anticipator |
| ODF | Outdoor Fan Relay |
| ODS | Outdoor Temperature Sensor |
| ODT | Outdoor Thermostat |
| RHS | Resistance Heat Switch |
| SC | Switchover Valve Solenoid |
| SM | System "On-Off" Switch |
| TDL | Discharge Line Thermostat |
| TNS | Transformer |
| TSC | Cooling Thermostat |
| TSH | Heating Thermostat |

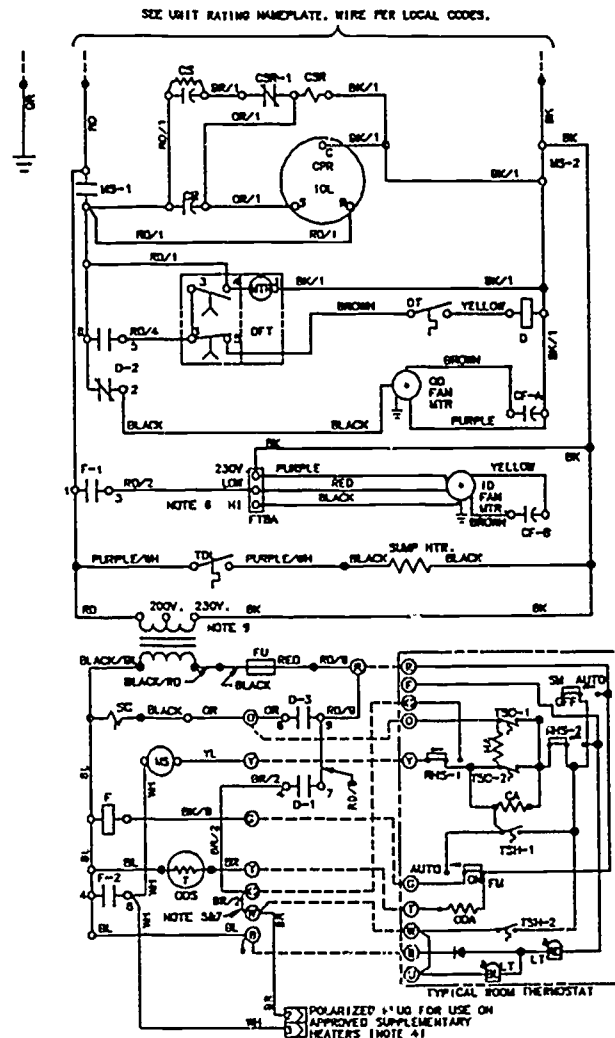

Schematic from service literature provided by the Trane Company, a division of American Standard Inc.

HEAT PUMP SYSTEMS UNIT XIV

ASSIGNMENT SHEET #3 — TRACE OPERATIONAL CIRCUITS FOR A HEAT PUMP IN THE DEFROST MODE

Legend-Equipment Diagram

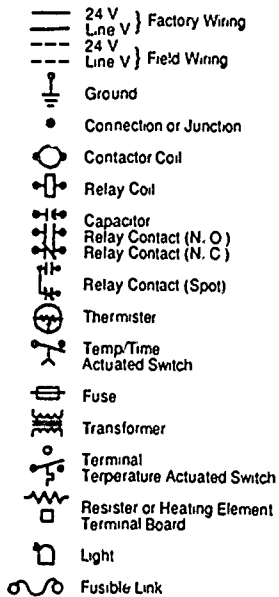

- CA Cooling Anticipator
- CF Far Capacitor
- CN Wire Connector
- CPR Compressor
- CR Run Capacitor
- CS Start Capacitor
- CSR Start Relay
- D Defrost Relay
- DFT Defrost Timer
- DT Defrost Termination Switch
- F Indoor Fan Relay
- FTB Fan Terminal Board
- FU Fuse
- HA Heat Anticipator
- HVTB High Voltage Terminal Board
- IOL Internal Overload Protector
- LT Light
- LVTB Low Voltage Terminal Board
- MS Compressor Contactor
- ODA Outdoor Temperature Anticipator
- ODF Outdoor Fan Relay
- ODS Outdoor Temperature Sensor
- ODT Outdoor Thermostat
- RHS Resistance Heat Switch
- SC Switchover Valve Solenoid
- SM System "On-Off" Switch
- TDL Discharge Line Thermostat
- TNS Transformer
- TSC Cooling Thermostat
- TSH Heating Thermostat

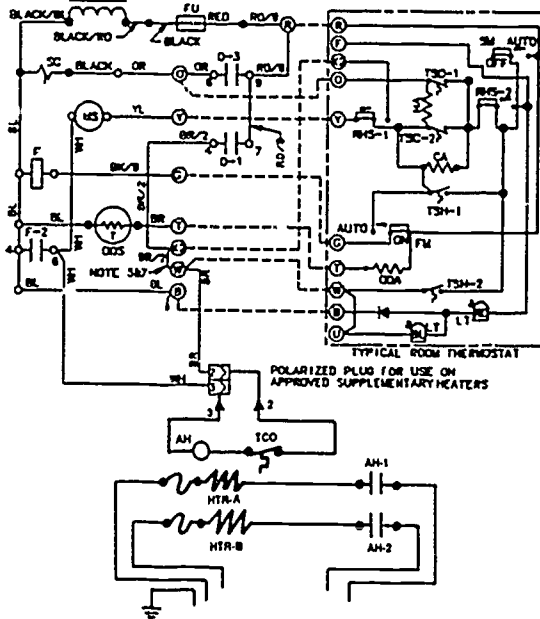
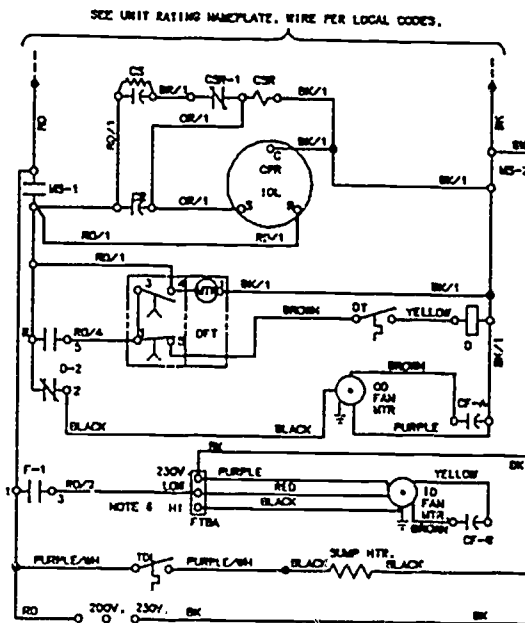

Schematic from service literature provided by the Trane Company, a division of American Standard Inc.

HEAT PUMP SYSTEMS UNIT XIV

ASSIGNMENT SHEET #4 — TRACE OPERATIONAL CIRCUITS FOR SECOND STAGE SUPPLEMENTARY HEAT IN A HEAT PUMP

Legend-Equipment Diagram

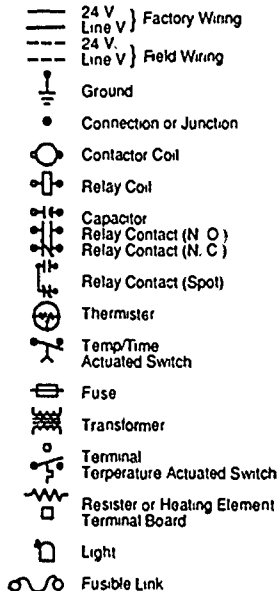

- CA Cooling Anticipator
- CF Fan Capacitor
- CN Wire Connector
- CPR Compressor
- CR Run Capacitor
- CS Start Capacitor
- CSR Start Relay
- D Defrost Relay
- DFT Defrost Timer
- DT Defrost Termination Switch
- F Indoor Fan Relay
- FTB Fan Terminal Board
- FU Fuse
- HA Heat Anticipator
- HVTB High Voltage Terminal Board
- IOL Internal Overload Protector
- LT Light
- LVTB Low Voltage Terminal Board
- MS Compressor Contactor
- ODA Outdoor Temperature Anticipator
- ODF Outdoor Fan Relay
- ODS Outdoor Temperature Sensor
- ODT Outdoor Thermostat
- RHS Resistance Heat Switch
- SC Switchover Valve Solenoid
- SM System "On-Off" Switch
- TDL Discharge Line Thermostat
- TNS Transformer
- TSC Cooling Thermostat
- TSH Heating Thermostat

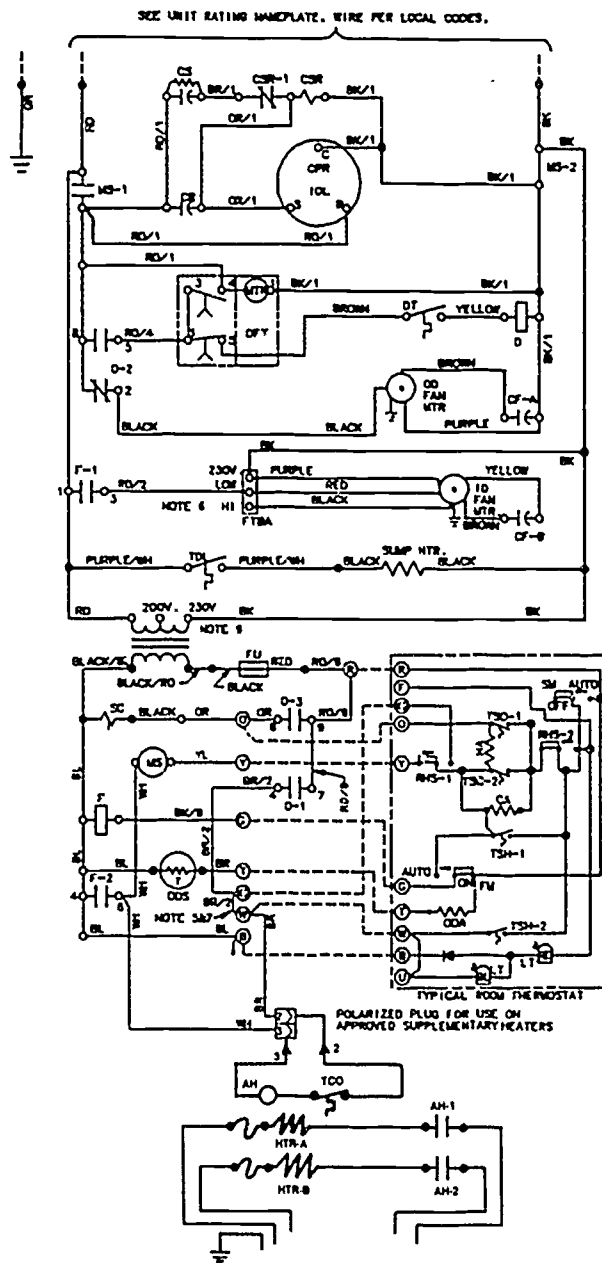

Schematic from service literature provided by the Trane Company, a division of American Standard Inc.

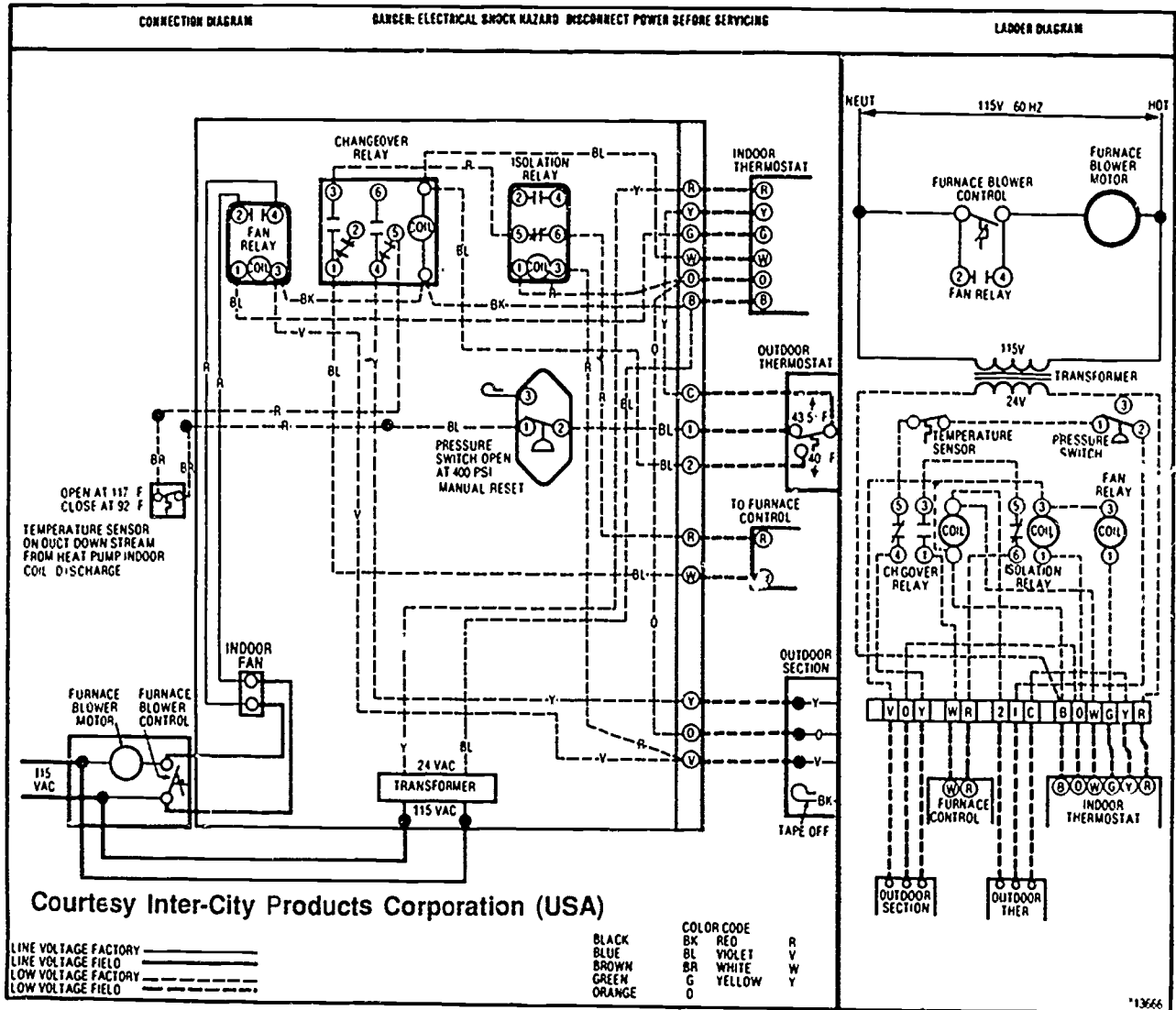

ASSIGNMENT SHEET #5 — TRACE OPERATIONAL CIRCUITS FOR A
 FOSSIL FUEL HEAT PUMP SYSTEM IN FIRST
 STAGE HEAT MODE ABOVE 45°F OUTDOOR AMBIENT (ADJUSTABLE)

HEAT PUMP SYSTEMS
 UNIT XIV

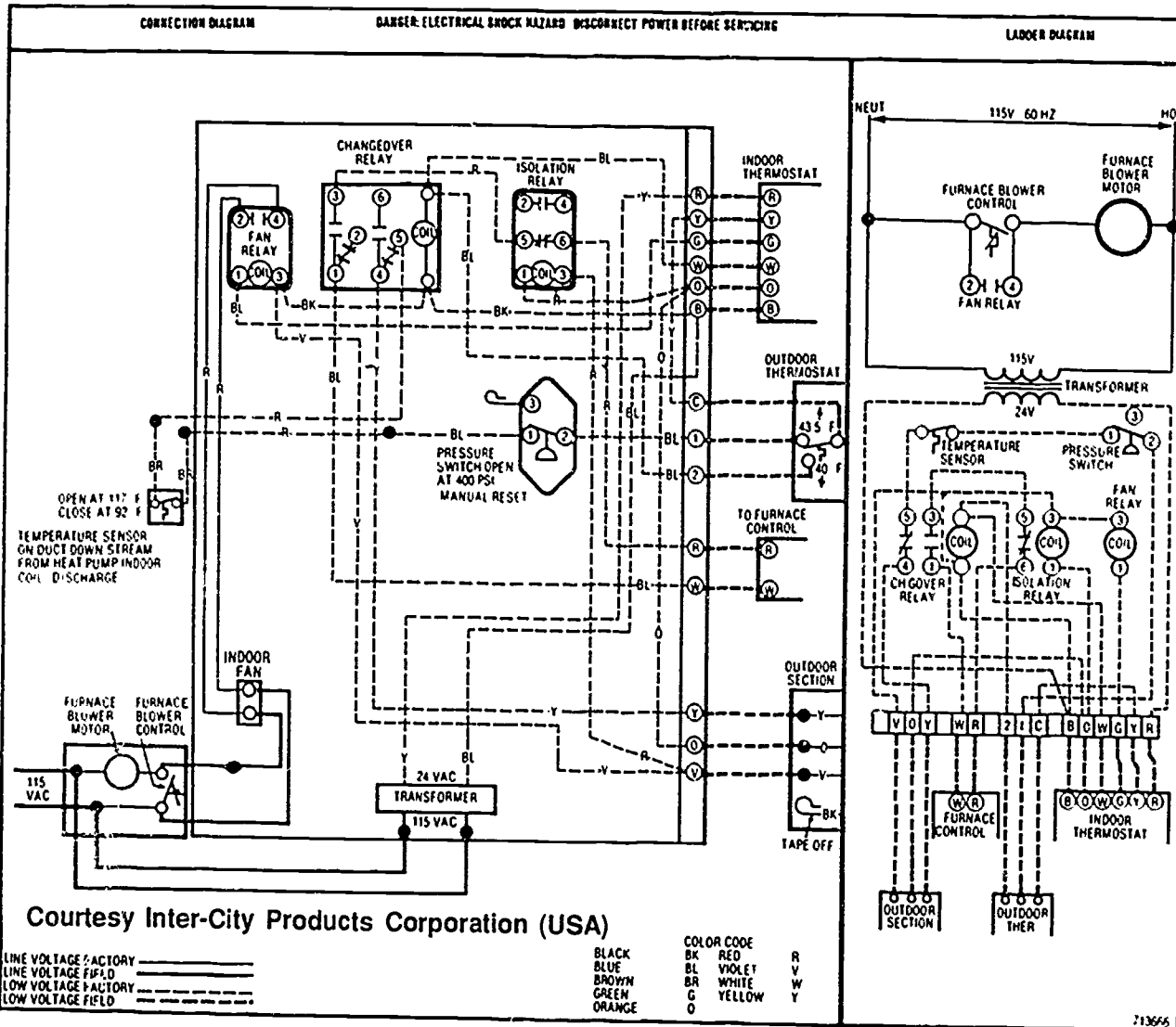

ASSIGNMENT SHEET #6 — TRACE OPERATIONAL CIRCUITS FOR A
 FOSSIL FUEL HEAT PUMP SYSTEM IN FIRST STAGE HEAT
 MODE BELOW 40°F OUTDOOR AMBIENT (ADJUSTABLE)

HEAT PUMP SYSTEMS
 UNIT XIV

HEAT PUMP SYSTEMS UNIT XIV

ANSWERS TO ASSIGNMENT SHEETS

Assignment Sheet #1

SCHEMATIC DIAGRAM

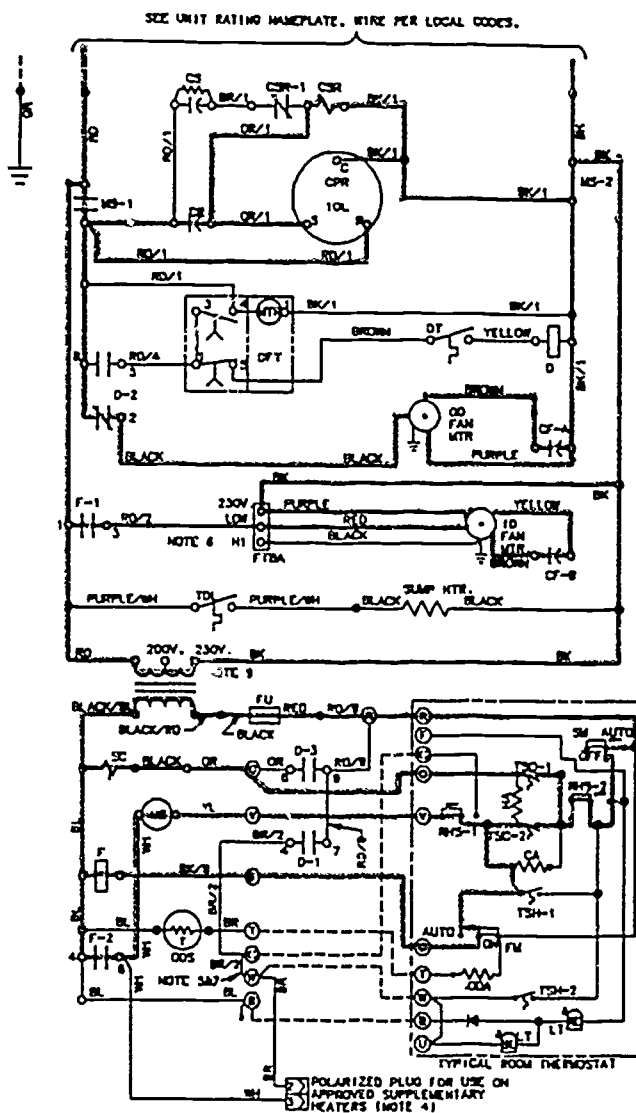

Schematic from service literature provided by the Trane Company, a division of American Standard Inc.

ANSWERS TO ASSIGNMENT SHEETS

Assignment Sheet #2

SCHEMATIC DIAGRAM

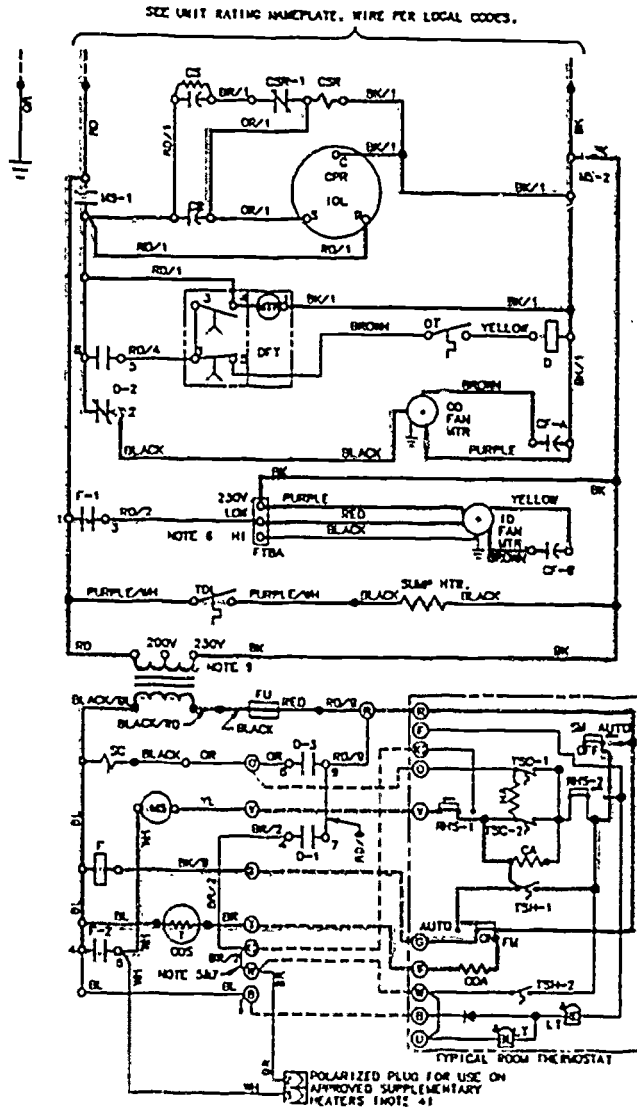

Schematic from service literature provided by the Trane Company, a division of American Standard Inc.

ANSWERS TO ASSIGNMENT SHEETS

Assignment Sheet #3

SCHEMATIC DIAGRAM

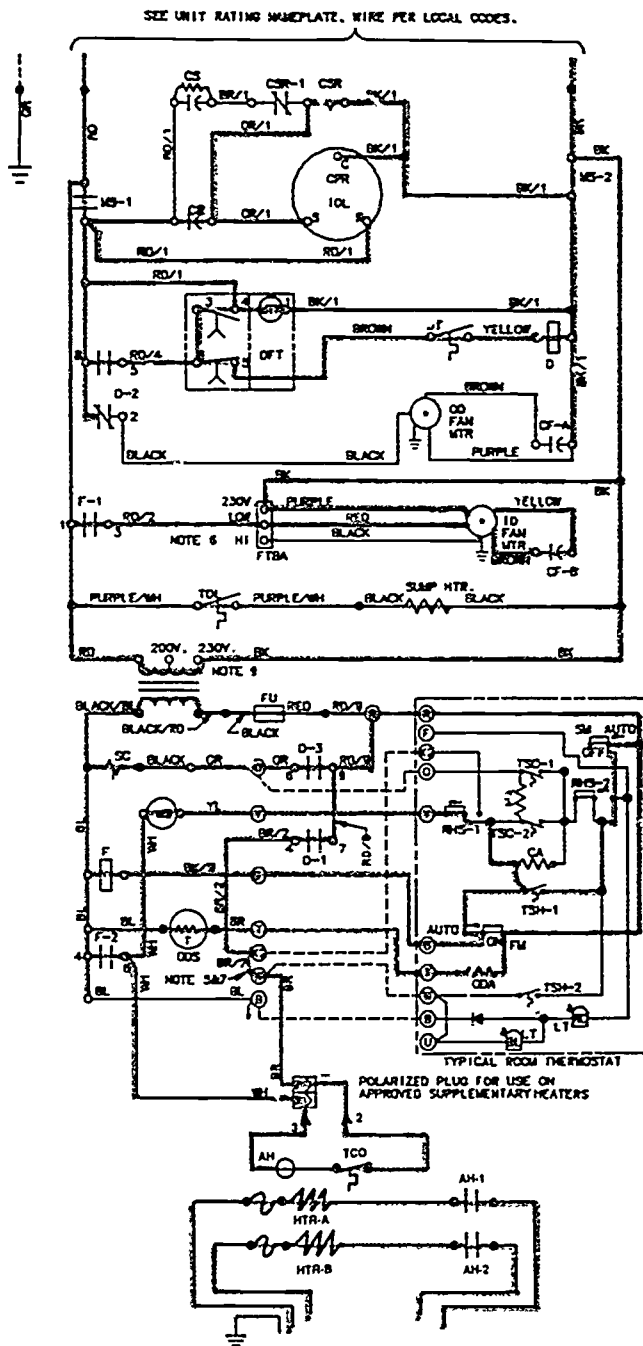

Schematic from service literature provided by the Trane Company, a division of American Standard Inc.

ANSWERS TO ASSIGNMENT SHEETS

Assignment Sheet #4

SCHEMATIC DIAGRAM

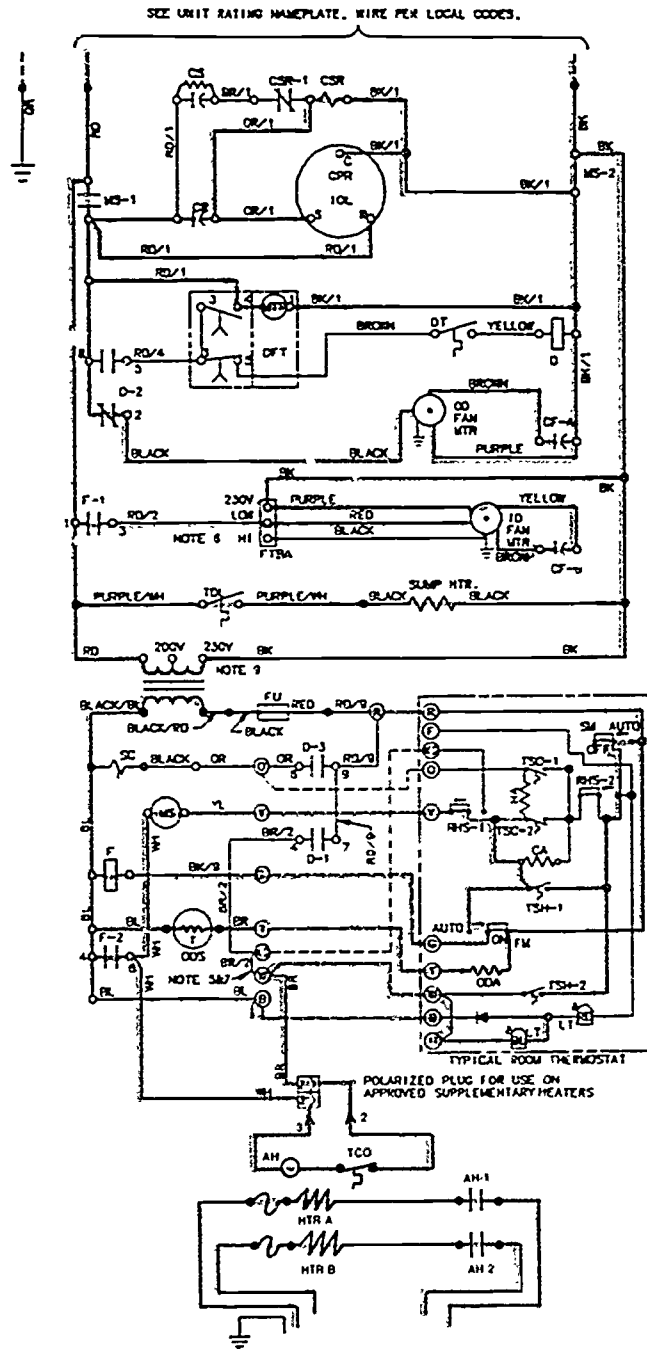

Schematic from service literature provided by the Trane Company, a division of American Standard Inc.

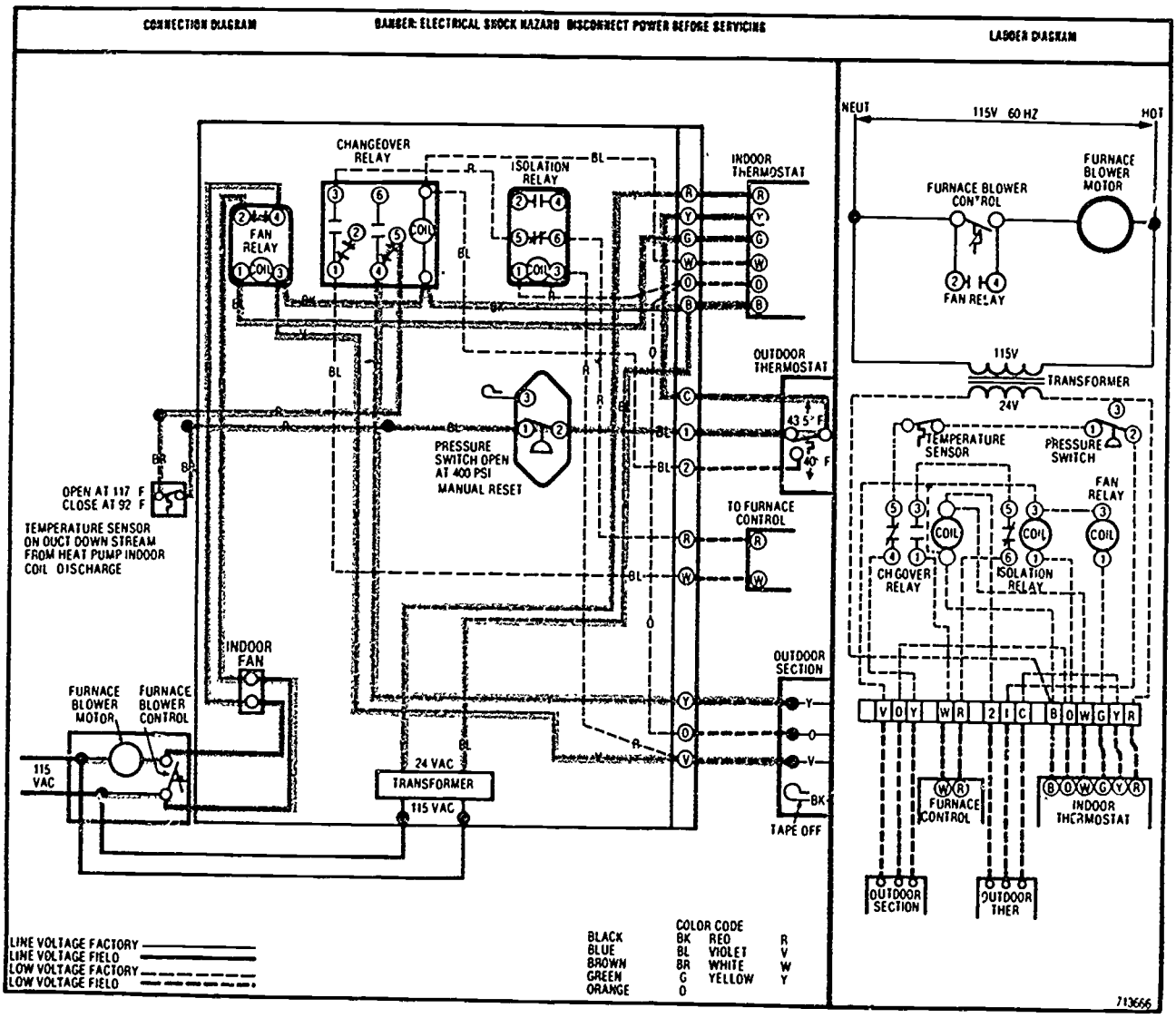

Courtesy Inter-City Products Corporation (USA)

Courtesy Inter-City Products Corporation (USA)

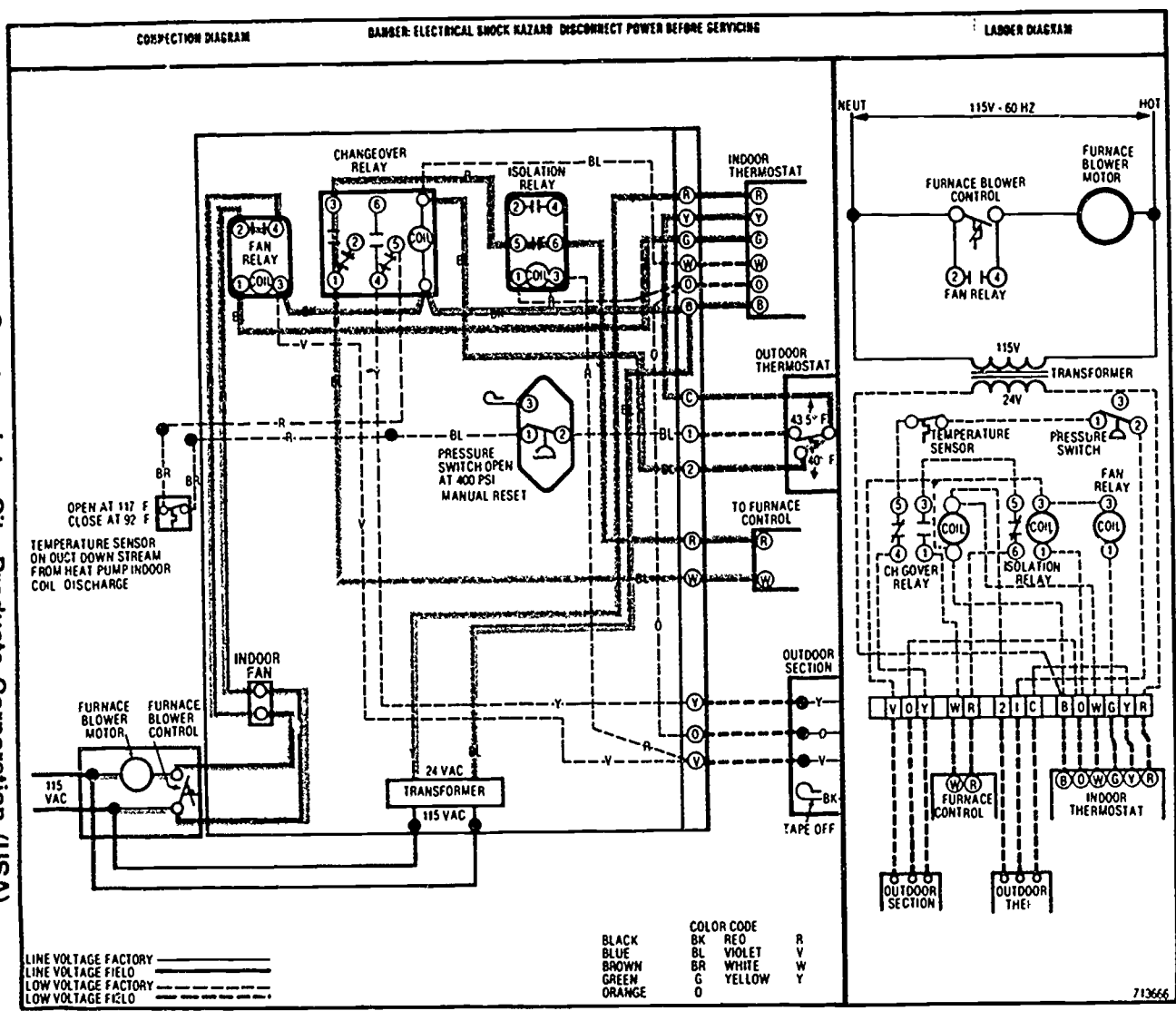

715

716

**HEAT PUMP SYSTEMS
UNIT XIV****JOB SHEET #1 — WIRE A CONTROL SYSTEM
FOR A HEAT PUMP****A. Tools and equipment**

1. Service technician's tool pouch/box
2. Voltmeter-ohmmeter
3. Heat pump trainer or system selected by instructor
4. Safety glasses

(NOTE: System should have wiring diagram recommended by manufacturer; diagram in Figure 1 is included for general reference.)

B. Procedure

1. Put on safety glasses and check for safe work area.
2. Check power source for proper voltage and capacity.
3. Apply power to system and verify voltage with a voltmeter.
4. Turn power off.
5. Wire necessary circuits to energize indoor fan motor.
6. Turn power on.
7. Operate indoor fan motor.
- Have instructor verify operation.
8. Turn power off.
9. Wire necessary circuits to operate cooling.
10. Turn power on.
11. Operate system for cooling.
- Have instructor verify operation.
12. Turn power off.
13. Wire necessary circuits for first stage heat (reverse cycle heating).

JOB SHEET #1

14. Turn power on.
15. Operate system for first stage heating.
- Have instructor verify operation.
16. Turn power off.
17. Wire necessary circuits for second stage supplemental heat.
18. Turn power on.
19. Operate system for second stage supplemental heat.
20. Turn power on.
21. Operate system for second stage supplemental heat.
- Have instructor verify operation.
22. Turn power off.
23. Wire necessary circuits for defrost.
24. Turn power on.
25. Operate system for defrost.
- Have instructor verify operation.
26. Turn power off.
27. Clean area and return tools.

JOB SHEET #1

FIGURE 1

SCHEMATIC DIAGRAM

Legend-Equipment Diagram

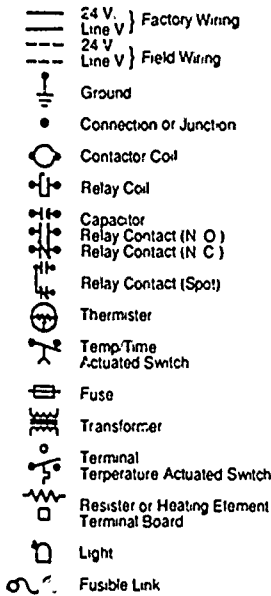

- CA Cooling Anticipator
- CF Fan Capacitor
- CN Wire Connector
- CPR Compressor
- CR Run Capacitor
- CS Start Capacitor
- CSR Start Relay
- D Defrost Relay
- DFT Defrost Timer
- DT Defrost Termination Switch
- F Indoor Fan Relay
- FTB Fan Terminal Board
- FU Fuse
- HA Heat Anticipator
- HVTB High Voltage Terminal Board
- IOL Internal Overload Protector
- LT Light
- LVTB Low Voltage Terminal Board
- MS Compressor Contactor
- ODA Outdoor Temperature Anticipator
- ODF Outdoor Fan Relay
- ODS Outdoor Temperature Sensor
- ODT Outdoor Thermostat
- RHS Resistance Heat Switch
- SC Switchover Valve Solenoid
- SM System "On-Off" Switch
- TDL Discharge Line Thermostat
- TNS Transformer
- TSC Cooling Thermostat
- TSH Heating Thermostat

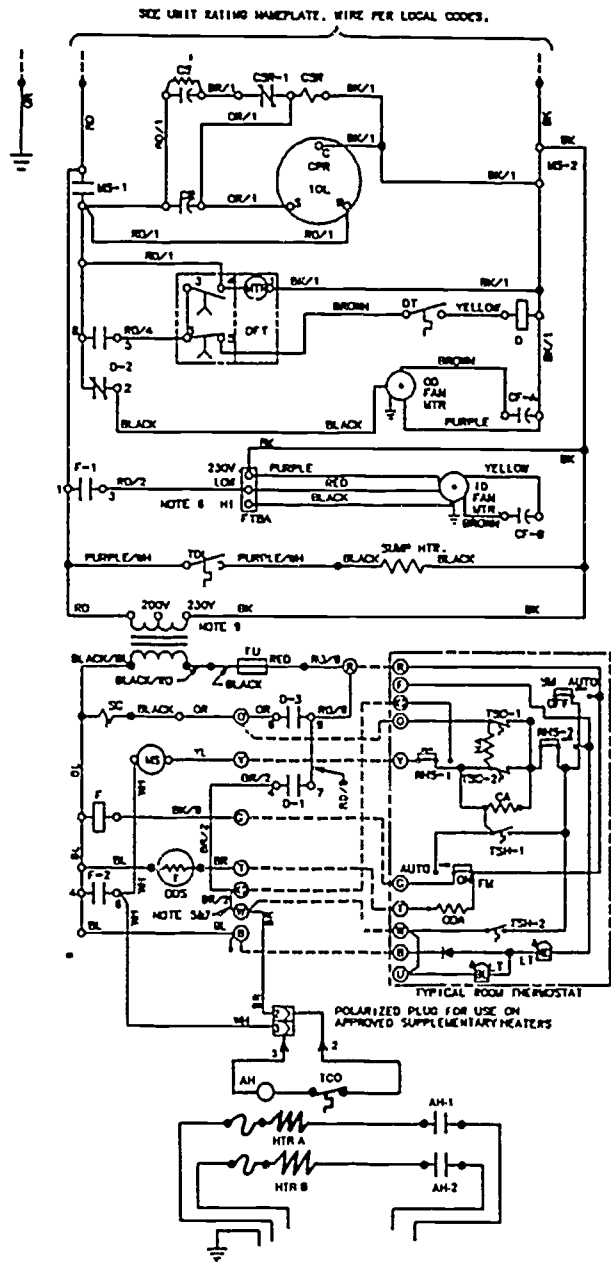

Schematic from service literature provided by the Trane Company, a division of American Standard Inc.

**HEAT PUMP SYSTEMS
UNIT XIV****JOB SHEET #2 — TROUBLESHOOT A HEAT PUMP INDOOR
SECTION IN THE COOLING MODE****A. Tools and equipment**

1. Technician's tool pouch/box
2. System as selected by instructor
3. Volt-ohmmeter
4. Scratch awl
5. Thermometer
6. Pencil and note pad
7. Duct tape
8. Safety glasses

B. Procedure

1. Put on safety glasses and check for safe work area.
2. Disconnect power from air handler and check with voltmeter.
3. Follow procedure for troubleshooting blower section.
4. Disconnect fan relay.
5. Measure resistance of fan relay coil and record whether OK _____
Open _____ Shorted _____ .
6. Disconnect secondary leads of transformer.
7. Measure resistance of secondary windings of transformer and record whether
OK _____ Open _____ Shorted _____ .
8. Disconnect primary windings of transformer.
9. Measure resistance of primary windings of transformer and record whether OK
_____ Open _____ Shorted _____ .

JOB SHEET #2

10. Measure resistance of each leg of transformer to ground and record whether OK _____ Grounded _____.
 - a. Question: Have all electrical components of the air handler fan circuit been tested? _____.
 - b. Has coil surface been checked and cleaned if needed? _____.
 - c. Is this equipment safe to energize? _____.
11. Reconnect fan relay and transformer
12. Energize air handler power circuit and check for proper voltage.
13. Energize fan circuit at thermostat subbase and note blower operation OK _____.
14. Set thermostat to "cool" and adjust to colder setting than room temperature.
(CAUTION: Be certain that scratch awl is not driven into cooling coil or electric heat strip section; inexperienced service people frequently do this.)
15. Drive scratch awl into return plenum and measure return air temperature and record _____ °F.
16. Drive scratch awl into supply plenum and measure supply temperature and record _____ °F.
17. Calculate temperature drop across cooling coil and record _____ °F.
18. Cover plenum holes with duct tape.
- Have your instructor evaluate your work.

721

**HEAT PUMP SYSTEMS
UNIT XIV****JOB SHEET #3 — PERFORM MAINTENANCE ON AN INDOOR
SECTION OF A HEAT PUMP IN THE COOLING MODE**

- A. Tools and equipment
1. Service technician's tool pouch/box
 2. System as selected by instructor
 3. Gloves and shop rag
 4. Scratch awl
 5. Thermometer
 6. Pencil and note pad
 7. Portable compressed air tank
 8. Safety glasses
- B. Procedure
1. Put on safety glasses and check for safe work area.
 2. Follow procedure for maintenance call on blower sections.
 3. Disconnect the condensate drain and blow it out with compressed air.
 4. Reconnect condensate drain.

(NOTE: Installers usually cement all joints in a new condensate drain line. The serviceman usually cuts the line with a hacksaw and after servicing reconnects the line with a coupling.)
 5. Set indoor thermostat to "cool" and adjust setting to cooler than room temperature.
 6. Feel suction line leaving evaporator.

(NOTE: Suction line should be cold but not freezing.)
 7. Wait for 15 minutes of continuous compressor operation then take temperature drop across indoor coil and record _____ °F.

JOB SHEET #3

8. Note any conditions which might affect air conditioner performance inside the structure:
- a. Abnormal indoor temperature
 - b. Furniture placement and draperies over supplies and returns
 - c. Improper design of supply register and duct
 - d. Thermostat above a lamp or other heat source
9. Reset thermostat to room temperature and note temperature difference between switching temperature and room temperature _____ °F.

(NOTE: Thermostats with mercury switches are sensitive to vibration; they must be checked, leveled, and secured.)

- Have your instructor evaluate your work.

**HEAT PUMP SYSTEMS
UNIT XIV****JOB SHEET #4 — TROUBLESHOOT A HEAT PUMP
ON A "NO COOLING" COMPLAINT****A. Tools and equipment**

1. Service technician's tool pouch/box
2. System as selected by instructor
3. Volt-ohm-ammeter
4. Gauge manifold (may be 3 gauge)
5. Gloves.
6. Replacement parts as required
7. Safety glasses

B. Procedure

1. Put on safety glasses and check for safe work area.
2. Set thermostat fan switch to "on."
3. Note blower response; if it fails to start, continue.
4. Check fuse to indoor section; if it is OK, continue.
5. Check output of transformer for 24 volts; if it is OK, continue.
6. Check for line voltage at the blower motor.
 - a. If voltage is not present, the fan relay is probably bad, but it could also be a broken or burned wire in a circuit.
 - b. If voltage is present, it could mean the motor is bad, but check the run capacitor first.
 - c. If the run capacitor is bad, replace it, and then check the motor.
7. Check indoor blower section to make sure coil and filter are clean so the section will operate normally.
8. Energize blower section for normal operation.
9. Check condenser fan; if it is not operating, continue.
10. Remove control box cover.

JOB SHEET #4

11. Note position of contactor carriage.

(NOTE: Some contactor carriages are covered with a plastic plate which must be removed; others are mounted in such a way that inspection will not reveal whether points are open or closed.)

- a. If the contactor points are open, check for 24V at the contactor coil.
- b. If there is 24V at the contactor coil, replace the bad contactor.
- c. If there is not 24V at the contactor coil, look for an open circuit, maybe a broken wire.

(NOTE: Lawn trimmers sometimes cut a wire, and dogs have been known to chew a wire in two, so the line should be protected with conduit.)

- d. If contactor points are closed, continue troubleshooting.

12. Determine if fan and compressor will run when contactor is closed; if they do not run, continue.

13. Check for line voltage at the contactor terminals; if there is no line voltage, continue.

14. Check fuse to condenser circuit; if line voltage is present, continue.

15. Look for a tripped safety device (usually a high pressure cutout).

16. Reset safety device; if no safety device is present, continue.

17. Note compressor and fan operation.

18. Feel the compressor; if it is hot and not running, this indicates the compressor internal overload may be open.

(NOTE: Do not confuse an overheated compressor with the heat of a normally operating crankcase heater; when a compressor is too hot to hold a hand on it for a few seconds, it is overheated.)

19. Follow procedure for checking out the hard start kit, run capacitor, and motor windings if the compressor fails to run when line voltage is applied.

20. Check condenser fan; if it does not run while contactor is closed, continue.

21. Check condenser fan motor; if it is OK, continue.

(NOTE: Sometimes condenser fan motors will run a long time before they heat up and quit. A bad condenser fan motor that has had time to cool off may fool a service technician by running beautifully when it is first energized.)

JOB SHEET #4

22. Look for cause of high head pressure once it has been established that the compressor is out on internal overload and high pressure cutout has been tripped.

(NOTE: Leaves, grass clippings, clothes dryer lint, etc., can clog a condenser coil and cause high head pressure; a newspaper or other obstruction to air flow can also cause it.)

23. Establish that there is no apparent reason for high head pressure, high pressure cutout has been tripped. and fan and compressor both run when reset, and continue.

24. Follow procedure for checking the cutout point of the high pressure cutout, and continue.

(NOTE: Install gauge manifold, start equipment, and note pressures; block air flow through condenser coils with newspaper until cutout trips and note cut-out pressure, this should be approximately 400 psi; some cutouts are adjustable, but many are not.)

25. Replace control box cover and panel and all screws.

26. Clean up tools and area and put tools away.

- Have you instructor evaluate your work.

HEAT PUMP SYSTEMS UNIT XIV

JOB SHEET #5 — TROUBLESHOOT A HEAT PUMP OUTDOOR SECTION ON AN "INSUFFICIENT COOLING" COMPLAINT

A. Tools and equipment

1. Service technician's tool pouch/box
2. Volt-ohm-ammeter
3. Gauge manifold
4. System as selected by instructor
5. Gloves
6. Safety glasses

B. Procedure

1. Follow procedures for checking a cooling only condenser section.
2. Put on safety glasses and gloves and check for safe work area.
3. Put unit in the "off" position and install the gauge manifold.
4. Connect suction pressure gauge to port installed in the suction line between the compressor and the reversing valve.

(CAUTION: Damage to the suction gauge may occur if it is connected to the vapor line outside the cabinet and operated in the "heating cycle".)

5. Use manufacturer's charging table to check operating pressures.
6. Follow procedures for checking compressor valves, reversing valve and check valves if pressures do not conform to charging tables.

(NOTE: Sometimes it is necessary to remove the refrigerant from the system and weigh in the proper charge to establish a "known" before condemning expensive parts. Always follow manufacturer's specifications.)

7. Check to see if pressures appear abnormally high with proper charge and a clean outdoor coil.
8. Check to see if some supplemental heat is coming on due to a sequencer or relay with contacts burned together.
9. Turn unit off and remove gauges.

- Have your instructor evaluate your work.

JOB SHEET #5

10. Clean work area and put tools away.

**HEAT PUMP SYSTEMS
UNIT XIV****JOB SHEET #6 — PERFORM MAINTENANCE ON
OUTDOOR SECTION OF A HEAT PUMP****A. Tools and equipment**

1. Service technician's tool pouch/box
2. Volt-ohm-ammeter
3. Gauge manifold
4. System as selected by instructor
5. Gloves
6. Safety glasses

B. Procedure

1. Put on safety glasses and check for safety work area.
2. Check for proper location and elevation of the outdoor section.
3. Turn power "off", gain access to the fan motor, and lubricate to manufacturer's instructions.

(NOTE: Many fan motors are sealed and cannot be lubricated)
4. Remove control panel cover and make a visual inspection of control components.
5. Check all electrical connections and repair as needed.
6. Remove compressor terminal cover and check for loose connections, repairing if necessary.
7. Inspect outdoor coil and clean if necessary.
8. Connect gauges to the proper ports.
9. Turn thermostat to the "off" setting.
10. Turn main power on.
11. Touch crankcase heater or check amp draw to determine condition.

(NOTE: Current draw is small enough that you will probably need to use a multiplier, and remember that a PTCR heater heats only when necessary.)

JOB SHEET #6

12. Set thermostat to call for cooling.
13. Check operating pressures.
14. Set thermostat to call for heating.
15. Check operating pressures.
16. Measure amp draw of outdoor fan motor and compare with nameplate specifications.
17. Measure amp draw of compressor and compare with nameplate specifications.
18. Check operation of lockout relay if present.
19. Check high pressure cutout if present.
20. Turn unit "off."
21. Remove gauges.
- Have your instructor evaluate your work.
22. Replace control cover.
23. Clean work area and put tools away.

730

HEAT PUMP SYSTEMS UNIT XIV

JOB SHEET #7 — TROUBLESHOOT SUPPLEMENTAL HEAT ON A HEAT PUMP

- A. Tools and equipment
1. Service technician's tool pouch/box
 2. Volt-ohm-ammeter
 3. System as selected by instructor
 4. Safety glasses
- B. Procedure
1. Put on safety glasses and check for safe work area.
 2. Disconnect power source.
 3. Remove cover of control box.
 4. Check for voltage at power lugs to determine that power is "off."
 5. Check for continuity and grounded heating elements:
 - a. Set volt-ohmmeter to measure resistance.
 - b. Remove power wires from elements.
 - c. Measure resistance of heating elements and record:
#1 _____ ohms #2 _____ ohms #3 _____ ohms.
 6. Check contactor and sequencers for continuity:
 - a. Set volt-ohmmeter to measure resistance.
 - b. Disconnect low voltage wires from contactor and/or sequencer #1.
 - c. Measure resistance of contactor coil and record.
 - d. Measure resistance of sequencer heater and record.
 - e. Measure resistance of any other sequencer heaters and record:
#2 _____ ohms #3 _____ ohms.
 - f. Reconnect low voltage wires to contactor and sequencer.

JOB SHEET #7

- g. Question: What could be the resistance of:
- a) An open coil circuit? _____ohms.
 - b) A burned out coil? _____ohms.
- h. Question: What would be the resistance of:
- a) An open heater circuit in a sequencer? _____ohms.
 - b) A shorted heater circuit? _____ohms.
7. Check continuity and grounding of blower power circuit.
8. Check continuity of fan relay coil circuit:
- a. Set volt-ohmmeter to measure resistance.
 - b. Disconnect control wires from fan relay.
 - c. Measure resistance of fan relay coil and record _____ohms.
 - d. Reconnect control wires to fan relay.
9. Check resistance of primary and secondary windings of low voltage transformer.
- (CAUTION: Be sure correct primary leads are connected if it is a multi-voltage transformer.)
- a. Set volt-ohmmeter to measure resistance.
 - b. Disconnect secondary leads from transformer.
 - c. Measure resistance of secondary windings of transformer and record: _____ ohms.
 - d. Disconnect primary leads from transformer.
 - e. Measure resistance of primary windings of transformer and record: _____ ohms.
 - f. Measure resistance from each leg of primary winding to ground and record: L_1 to ground _____ohms; L_2 to ground _____ ohms.
 - g. Reconnect secondary and primary leads of transformer.
 - h. Question: Is secondary winding of the transformer shorted? _____, open? _____.

JOB SHEET #7

- i. Question: Have all the circuits in the heating elements been checked?
_____.
- j. Are the heating elements safe to energize? _____.
10. Reconnect power source.
11. Set thermostat for supplemental heat to "on."
12. Check and record voltage and amp draw for each heater:
- | | Voltage | Amps |
|----|---------|-------|
| #1 | _____ | _____ |
| #2 | _____ | _____ |
| #3 | _____ | _____ |
13. Set thermostat to the "off" position.
14. Replace control box cover.
- Have you instructor evaluate your work.
15. Clean area and put tools away.

**HEAT PUMP SYSTEMS
UNIT XIV**

**JOB SHEET #8 — PERFORM MAINTENANCE ON HEAT PUMP
SUPPLEMENTAL HEATING**

A. Tools and equipment

1. Service technician's tool pouch/box
2. Thermometer and scratch awl
3. Shop rag
4. Ammeter-voltmeter
5. System as selected by instructor
6. Safety glasses

B. Procedure

1. Put on safety glasses and check for safe work area.
2. Open main power switch.
3. Remove control box cover.
4. Service blower section.
5. Energize heater strips and record fan motor amperage draw: _____
6. De-energize strips and snap ammeter over wire power lug to main power source.
7. Set thermostat to "heat" and close the second stage thermostat.
8. Close the outdoor thermostats.
9. Re-energize strips and record voltage amp and draw of heaters as sequencers close heater circuits:

Blower motor and heater

#1 _____ amps _____ volts.

#2 _____ amps _____ volts.

#3 _____ amps _____ volts.

#4 _____ amps _____ volts.

JOB SHEET #8

10. Compare full load amps with strip heater nameplate rating. (Figure 1)

FIGURE 1

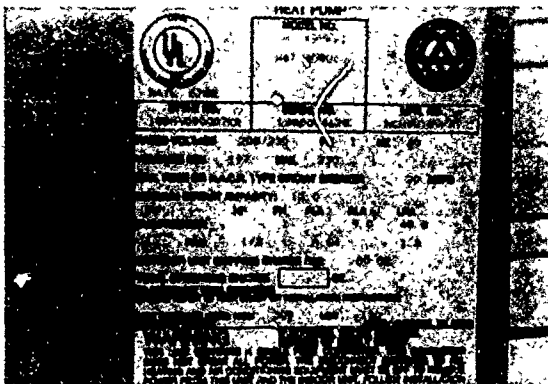

11. Determine if all of the elements are pulling the proper amperage.
12. Drive scratch awl into return air plenum, insert thermometer, and record return air temperature _____°F.
13. Select a place in the supply trunk which is out of the "line of sight" of the electric heater elements and drive scratch awl into supply trunk. Record supply air temperature _____°F.
14. Record temperature rise through indoor section _____°F.
15. Remove thermometer and plug holes.
16. Adjust outdoor thermostats to previous settings.
17. De-energize supplemental heat at disconnect.
18. Replace control box cover.
19. Re-energize supplemental heat.
20. Reset thermostat to proper setting.
- Have your instructor evaluate your work.
21. Clean area and put tools away.

**HEAT PUMP SYSTEMS
UNIT XIV****JOB SHEET #9 — TROUBLESHOOT A HEAT PUMP ON A "NO HEAT"
COMPLAINT WHEN THE COMPRESSOR WILL NOT RUN****A. Tools and equipment**

1. Service technician's tool pouch/box
2. Volt-ohm-ammeter
3. System as selected by instructor
4. Safety glasses

B. Procedure

1. Put on safety glasses and check for safe work area.
2. Disconnect power supply.
3. Set volt-ohmmeter to measure resistance.
4. Check contactor; it is open, continue.
 - a. Check for malfunction at low voltage transformer.
 - b. Check for malfunction in remote control center.
 - c. Check to see if contactor coil is open or shorted.
 - d. Check time delay devices for malfunction.
 - e. Check for an open pressure switch.
 - f. Check control circuit to see if it is open.
5. Reconnect power supply and energize system.
6. Check charge in system, and record high pressure reading _____, and low pressure reading _____.
7. Check contactor; if it is closed, continue:
 - a. Check for open power supply to compressor.
 - b. Measure and record amp reading to see if compressor is stuck _____.
8. Disconnect power supply.

JOB SHEET #9

9. Check for loose leads at the compressor.
10. Check compressor windings to make sure they are not open, shorted, or grounded.
11. Check to see if compressor overload is open.
12. Obtain instructor's OK before reconnecting power supply.
- Have your instructor evaluate your work.
13. Clean area and put tools away.

737

HEAT PUMP SYSTEMS UNIT XIV

JOB SHEET #10 — TROUBLESHOOT A HEAT PUMP ON A "NO HEAT" COMPLAINT WHEN THE COMPRESSOR RUNS BUT CYCLES ON COMPRESSOR OVERLOAD

A. Tools and equipment

1. Service technician's tool pouch/box
2. Volt-ohm-ammeter
3. Gauge manifold
4. System as selected by instructor
5. Safety glasses

B. Procedure

1. Put on safety glasses and check for safe work area.
2. Check for dirty filters.
3. Check indoor coil to make sure it is free of dirt and debris.
4. Check indoor fan; if it is not cycling on overload; continue:
5. Check for malfunction or damage to the reversing valve.
6. Make sure reversing valve is not stuck in mid-position.
7. Check temperature across the valve to verify that incoming and outgoing temperatures are close to the same.
8. Check for restriction in discharge line.
9. Check system for overcharge and record pressures _____.
10. Check system for undercharge and record pressures _____.
11. Check for high or low line voltage and record voltage _____.
12. Check for malfunction in run capacitor.
13. Check high load condition.
14. Check high pressure control.

JOB SHEET #10

- Have your instructor evaluate your work.
15. Clean up area and put tools away.

39

HEAT PUMP SYSTEMS UNIT XIV

JOB SHEET #11 — TROUBLESHOOT A HEAT PUMP ON AN "INSUFFICIENT HEAT" COMPLAINT WHEN THE COMPRESSOR WILL RUN

- A. Tools and equipment
1. Service technician's tool pouch/box
 2. Volt-ohm-ammeter
 3. Gauge manifold
 4. System as selected by instructor
 5. Safety glasses
- B. Procedure
1. Put on safety glasses and check for safe work area.
 2. Check for low suction and low head; if both are present, continue.
 3. Check outdoor fan; if it is stopped, continue:
 4. Check for loose leads at fan motor.
 5. Check to see if internal fan motor overload is open.
 6. Check to see if fan motor is shorted, grounded, or open.
 7. Check the run capacitor.
 8. Check to see if defrost relay contacts are open.
 9. Check outdoor fan; if it is running, continue.
 10. Check for stuck reversing valve.
 11. Check for restrictions in liquid line or for a defective metering device.
 12. Check for malfunction in outdoor metering device.
 13. Check for undercharged system and record high pressure _____, and low pressure _____.
 14. Check for dirty outdoor coil.
 15. Check outdoor coil; if it is heavily frosted, continue:
 16. Check for malfunction in defrost control.

JOB SHEET #11

17. Check to see if defrost thermostat is in poor physical contact with line.
18. Check for malfunction in defrost relay or defrost timer.
19. Check complete defrost circuit for any bad electrical connections.
20. Check strip heaters; if they are not operating, continue:
21. Set thermostat to energize second stage heating.
22. Check for malfunction in outdoor thermostat.
23. Determine if outdoor thermostat is set too low.
24. Check for pinched capillary tube or bulb not sensing true outdoor temperature.
25. Check for malfunction in strip heater relay or contactor.
26. Check power circuit to heater elements and record high voltage _____ and low voltage _____; if circuit to heater elements is open, continue.
27. Check for blown fuse link.
28. Check for a broken heater element.
29. Check for an open in the hi-limit switch.
- Have your instructor evaluate your work.
30. Check room thermostat for defective second stage control.
31. Clean up area and return tools.

741

HEAT PUMP SYSTEMS UNIT XIV

JOB SHEET #12 — CHECK OPERATION OF AN ESSEX SOLID STATE TIME-TEMPERATURE DEFROST CONTROL

A. Tools and equipment

1. Service technician's tool pouch/box
2. Volt-ohm-ammeter
3. Two cups or glasses and water
4. Two cups of crushed ice
5. Salt
6. Watch with second hand
7. Control or system as selected by instructor
8. Safety glasses

B. Procedure

1. Put on safety glasses and check for a safe work area.
2. Turn off all power to the unit
3. Place a jumper wire across the "TST" pins on the solid state board to accelerate the timing cycle.
4. Place a jumper across the defrost sensor to simulate a cold coil.
(CAUTION: Make sure jumpers are installed correctly, or a board failure could result.)
5. Set thermostat to call for heat.
6. Turn power on and watch for unit to cycle in and out of defrost until the jumpers are removed within the accelerated timing limits:
 - a. 90 minutes = 21 seconds
 - b. 60 minutes = 14 seconds
 - c. 30 minutes = 7 seconds
7. Turn power off.
8. Remove jumpers.

JOB SHEET #12

9. Disconnect sensor wiring and remove sensor.
10. Fill a small container approximately 75% with ice, and add water to the ice level.
11. Place a thermometer in the solution and add salt until the temperature reaches the 20-25°F range.
12. Fill another container with water approximately 70-75°F.
13. Connect an ohmmeter across the sensor leads and submerge sensor into the cold container.
14. Start timing: continuity should be read within approximately 60-90 seconds.
15. Place the sensor in the warm container.
16. Start timing: the switch should open in approximately 90 seconds.
17. Install sensor on the unit and reconnect wiring.
- Have your instructor evaluate your work.
18. Clean work area and put tools away.

**HEAT PUMP SYSTEMS
UNIT XIV****JOB SHEET #13 — CHECK OPERATION OF A RANCO E-15
MECHANICAL TIME-TEMPERATURE DEFROST CONTROL****A. Tools and equipment**

1. Service technician's tool pouch/box
2. Volt-ohm-ammeter
3. Two cups or glasses and water
4. Two cups of crushed ice
5. Salt
6. Ranco E-15 time/temperature control
7. Source of 240V power
8. Replacement E-15 unit as required
9. Safety glasses

B. Procedure

1. Check for a safe work area and put on safety glasses.
2. Check with your instructor for a safe procedure to wire 240V power to terminals TM and TM 1.

(NOTE: If you are working on an E-15 at a unit, it should already be properly wired.)
3. Turn power ON.
4. Use a voltmeter to check across terminals TM/TM 1 for verification of 240V power.
5. Look through the motor inspection window to verify that the motor is running.
 - a. If 240V is present, but the motor is not running, replace the E-15 unit.
 - b. If 240V is present and the motor is running, continue.
6. Look for the cam inspection window on the opposite side of the motor inspection window.

JOB SHEET #13

7. Rotate the cam stem clockwise with a screwdriver until the cam follower falls into the initiation notch.
 - a. If the cam does not move after one to two minutes, it indicates a problem in the drive mechanism, and the E-15 control needs to be replaced.
 - b. If the cam moves properly into the initiation notch, continue.
8. Turn the power OFF.
9. Rotate the cam stem clockwise with a screwdriver until the cam follower falls into the initiation notch.
10. Loosen the two screws that hold the diaphragm/bulb assembly to the control; loosen the screws, but do not remove them.
11. Move the assembly back and forth against the control and listen for a distinct click that will verify proper operation.

(NOTE: For the following checks, be sure the temperature is at least 55°F.)
12. Check terminals 1, 2, and 3 with an ohmmeter for proper continuity:
 - a. Terminals 2 to 3 should be normally closed.
 - b. Terminals 2 to 1 should be normally open.
 - c. If continuity is improper, it indicates a mechanical failure, burnt contacts, or loss of charge in the diaphragm/bulb assembly.
13. Retighten the two screws that hold the diaphragm/bulb assembly.
14. Check to verify that the cam follower is still in the initiation notch.
15. Place an ohmmeter across terminals 1 and 2.
 - a. If the bulb temperature is above 55°F, the circuit should be open.
 - b. If the circuit is closed, rotate the cam until the cam follower is on the high spot of the cam.
 - c. If the circuit opens at this point, the bulb is defective and the E-15 unit should be replaced.
16. Prepare a glass or cup of ice, water, and salt to make a brine solution.
17. Place the bulb into the brine solution and give it time enough to cool the bulb to at least 28°F.
18. Verify the temperature with your service thermometer.

745

JOB SHEET #13

19. Check continuity on terminals 1, 2, and 3 again:
 - a. Terminals 2 to 3 should be open.
 - b. Terminals 2 to 1 should be closed.
 - c. If continuity is improper, replace the E-15 unit.
20. Remove the bulb from the brine and hold the bulb in your hand until it warms to at least 55°F.
21. Verify the temperature with your service thermometer.
22. Check terminals 1, 2, and 3 for continuity again:
 - a. Terminals 2 and 3 should be closed.
 - b. Terminals 2 to 1 should be open.
 - c. If continuity is not correct, replace the E-15 unit.
 - d. If continuity is correct, the E-15 unit is okay.
23. Disconnect unit from power source.
- Have your instructor check your work.
24. Return tools and materials to storage.

HEAT PUMP SYSTEMS UNIT XIV

JOB SHEET #14 — CHECK OPERATION OF AN ESSEX 149-600 SOLID STATE DEMAND DEFROST CONTROL

- A. Tools and equipment
1. Service technician's tool pouch/box
 2. Volt-ohm-ammeter
 3. Gauges
 4. Electronic thermometer
 5. Watch
 6. System as selected by instructor
 7. Replacement Essex control as required
 8. Safety glasses
- B. Procedure
1. Put on safety glasses and check for a safe work area.
 2. Install gauges on the unit.
 3. Set thermostat to "call for heat" and run system during the test.
 4. Check the refrigerant charge and adjust if necessary, after 15 minutes run time.
 5. Use a voltmeter to make sure 24 volts are present at the 24V AC input terminals on the defrost control board.
 6. Use an electronic thermometer to check the coil sensor temperature and if it is below 38°F continue.
 - a. If the coil sensor temperature is above 38°F you will need to jumper the "HIB" terminals.

(CAUTION: Be careful to jumper only terminals according to instructions or the solid state board may be ruined.)
 - b. Momentarily jumpering the pins marked "40 MIN" will bypass the forty minute interval between defrost cycles one time.
 7. Jumper the "INIT" pins momentarily.

JOB SHEET #14

- a. The unit should reverse cycle, going into defrost.
- b. The defrost cycle should terminate and the unit switch back into heating when one of the following occur:
 - 1) Coil sensor temperature increases to 60°F or above.
 - 2) The 13.7 minute override time has occurred.
8. Turn the unit off.
9. Remove the jumper from the "INHIB" terminals if one had to be used.
10. Remove gauges, and if the defrost system failed the above test the board and sensors must be replaced.
- Have your instructor check your work.
11. Clean area and return equipment to proper storage.

745

**HEAT PUMP SYSTEMS
UNIT XIV**

PRACTICAL TEST #1

JOB SHEET #1 — WIRE A CONTROL SYSTEM FOR A HEAT PUMP

Student's name _____ Date _____

Evaluator's name _____ Attempt no. _____

Student instructions: When you are ready to perform this task, ask your instructor to observe the procedure and complete this form. All items listed under "Process Evaluation" must receive a "yes" for you to receive an overall performance evaluation.

PROCESS EVALUATION

(EVALUATOR NOTE: Place a check mark in the "Yes" or "No" blanks to designate whether or not the student has satisfactorily achieved each step in this procedure. If the student is unable to achieve this competency, have the student review the materials and try again.)

The student:	YES	NO
1. Wired circuit for indoor fan motor.	<input type="checkbox"/>	<input type="checkbox"/>
2. Verified indoor fan operation.	<input type="checkbox"/>	<input type="checkbox"/>
3. Wired circuits to operate cooling.	<input type="checkbox"/>	<input type="checkbox"/>
4. Verified cooling operation.	<input type="checkbox"/>	<input type="checkbox"/>
5. Wired circuits to operate first stage heat.	<input type="checkbox"/>	<input type="checkbox"/>
6. Verified first stage heating.	<input type="checkbox"/>	<input type="checkbox"/>

Evaluator's comments: _____

JCB SHEET #1 PRACTICAL TEST

PRODUCT EVALUATION

(EVALUATOR NOTE: Rate the student on the following criteria by circling the appropriate numbers. Each item must be rated at least a "3" for mastery to be demonstrated. (See performance evaluation key below.) If the student is unable to demonstrate mastery, student materials should be reviewed and another test procedure must be submitted for evaluation.)

Criteria:

Use of proper schematics	4	3	2	1
Indoor fan wiring	4	3	2	1
Cooling system wiring	4	3	2	1
First stage heat wiring	4	3	2	1

EVALUATOR'S COMMENTS: _____

PERFORMANCE EVALUATION KEY

- 4 — **Skilled** — Can perform with no additional training.
- 3 — **Moderately skilled** — Has performed job during training program; limited additional additional training may be required.
- 2 — **Limited skill** — has performed job during training program; additional training is required to develop skill.
- 1 — **Unskilled** — Is familiar with process, but is unable to perform job.

(EVALUATOR NOTE: If an average score is needed to coincide with a competency profile, total the designated points in "Product Evaluation" and divide by the total number of criteria.)

**HEAT PUMP SYSTEMS
UNIT XIV**

PRACTICAL TEST #2

**JOB SHEET #2 — TROUBLESHOOT A HEAT PUMP INDOOR
SECTION IN THE COOLING MODE**

Student's name _____ Date _____

Evaluator's name _____ Attempt no. _____

Student instructions: When you are ready to perform this task, ask your instructor to observe the procedure and complete this form. All items listed under "Process Evaluation" must receive a "yes" for you to receive an overall performance evaluation.

PROCESS EVALUATION

(EVALUATOR NOTE: Place a check mark in the "Yes" or "No" blanks to designate whether or not the student has satisfactorily achieved each step in this procedure. If the student is unable to achieve this competency, have the student review the materials and try again.)

The student:	YES	NO
1. Completed troubleshooting blower section.	<input type="checkbox"/>	<input type="checkbox"/>
2. Checked fan relay coil resistance.	<input type="checkbox"/>	<input type="checkbox"/>
3. Checked transformer secondary windings.	<input type="checkbox"/>	<input type="checkbox"/>
4. Checked transformer primary windings.	<input type="checkbox"/>	<input type="checkbox"/>
5. Measured each leg of transformer to ground.	<input type="checkbox"/>	<input type="checkbox"/>
6. Checked and cleaned coil as required.	<input type="checkbox"/>	<input type="checkbox"/>
7. Checked return and supply air temperature.	<input type="checkbox"/>	<input type="checkbox"/>
8. Covered plenum holes with duct tape.	<input type="checkbox"/>	<input type="checkbox"/>

Evaluator's comments: _____

JOB SHEET #2 PRACTICAL TEST

PRODUCT EVALUATION

(EVALUATOR NOTE: Rate the student on the following criteria by circling the appropriate numbers. Each item must be rated at least a "3" for mastery to be demonstrated. (See performance evaluation key below.) If the student is unable to demonstrate mastery, student materials should be reviewed and another test procedure must be submitted for evaluation.)

Criteria:

Fan relay coil troubleshooting	4	3	2	1
Transformer windings troubleshooting	4	3	2	1
Transformer to ground troubleshooting	4	3	2	1
Supply and return air measurements	4	3	2	1

EVALUATOR'S COMMENTS: _____

PERFORMANCE EVALUATION KEY

- 4 — **Skilled** — Can perform with no additional training.
- 3 — **Moderately skilled** — Has performed job during training program; limited additional additional training may be required.
- 2 — **Limited skill** — has performed job during training program; additional training is required to develop skill.
- 1 — **Unskilled** — Is familiar with process, but is unable to perform job.

(EVALUATOR NOTE: If an average score is needed to coincide with a competency profile, total the designated points in "Product Evaluation" and divide by the total number of criteria.)

**HEAT PUMP SYSTEMS
UNIT XIV**

PRACTICAL TEST #3

**JOB SHEET #3 — PERFORM MAINTENANCE ON AN INDOOR
SECTION OF A HEAT PUMP IN THE COOLING MODE**

Student's name _____ Date _____

Evaluator's name _____ Attempt no. _____

Student instructions: When you are ready to perform this task, ask your instructor to observe the procedure and complete this form. All items listed under "Process Evaluation" must receive a "yes" for you to receive an overall performance evaluation.

PROCESS EVALUATION

(EVALUATOR NOTE: Place a check mark in the "Yes" or "No" blanks to designate whether or not the student has satisfactorily achieved each step in this procedure. If the student is unable to achieve this competency, have the student review the materials and try again.)

The student:	YES	NO
1. Maintained blower sections.	<input type="checkbox"/>	<input type="checkbox"/>
2. Cleaned condensate drain.	<input type="checkbox"/>	<input type="checkbox"/>
3. Took temperature drop across coil.	<input type="checkbox"/>	<input type="checkbox"/>
4. Noted structure conditions that might affect air conditioning.	<input type="checkbox"/>	<input type="checkbox"/>
5. Checked difference between room temperature and switching temperature.	<input type="checkbox"/>	<input type="checkbox"/>

Evaluator's comments: _____

JOB SHEET #3 PRACTICAL TEST

PRODUCT EVALUATION

(EVALUATOR NOTE: Rate the student on the following criteria by circling the appropriate numbers. Each item must be rated at least a "3" for mastery to be demonstrated. (See performance evaluation key below.) If the student is unable to demonstrate mastery, student materials should be reviewed and another test procedure must be submitted for evaluation.)

Criteria:

Blower section service	4	3	2	1
Condensate drain service	4	3	2	1
Temperature drop across coil check	4	3	2	1
Switching temperature check	4	3	2	1

EVALUATOR'S COMMENTS: _____

PERFORMANCE EVALUATION KEY

- 4 — **Skilled** — Can perform with no additional training.
- 3 — **Moderately skilled** — Has performed job during training program; limited additional additional training may be required.
- 2 — **Limited skill** — has performed job during training program; additional training is required to develop skill.
- 1 — **Unskilled** — Is familiar with process, but is unable to perform job.

(EVALUATOR NOTE: If an average score is needed to coincide with a competency profile, total the designated points in "Product Evaluation" and divide by the total number of criteria.)

**HEAT PUMP SYSTEMS
UNIT XIV**

PRACTICAL TEST #4

**JOB SHEET #4 — TROUBLESHOOT A HEAT PUMP
ON A "NO COOLING" COMPLAINT**

Student's name _____ Date _____

Evaluator's name _____ Attempt no. _____

Student instructions: When you are ready to perform this task, ask your instructor to observe the procedure and complete this form. All items listed under "Process Evaluation" must receive a "yes" for you to receive an overall performance evaluation.

PROCESS EVALUATION

(EVALUATOR NOTE: Place a check mark in the "Yes" or "No" blanks to designate whether or not the student has satisfactorily achieved each step in this procedure. If the student is unable to achieve this competency, have the student review the materials and try again.)

The student:	YES	NO
1. Checked fuse, transformer, and line voltage at blower motor.	<input type="checkbox"/>	<input type="checkbox"/>
2. Checked coil, filter, and indoor blower section.	<input type="checkbox"/>	<input type="checkbox"/>
3. Completed condenser fan contactor checks.	<input type="checkbox"/>	<input type="checkbox"/>
4. Check for compressor internal overload.	<input type="checkbox"/>	<input type="checkbox"/>
5. Checked for cause of high head pressure.	<input type="checkbox"/>	<input type="checkbox"/>
6. Checked cutout point of high pressure cutout.	<input type="checkbox"/>	<input type="checkbox"/>
7. Checked out hard start kit, capacitor, and motor windings as required.	<input type="checkbox"/>	<input type="checkbox"/>
8. Corrected "no cooling" complaint.	<input type="checkbox"/>	<input type="checkbox"/>

Evaluator's comments: _____

JOB SHEET #4 PRACTICAL TEST

PRODUCT EVALUATION

(EVALUATOR NOTE: Rate the student on the following criteria by circling the appropriate numbers. Each item must be rated at least a "3" for mastery to be demonstrated. (See performance evaluation key below.) If the student is unable to demonstrate mastery, student materials should be reviewed and another test procedure must be submitted for evaluation.)

Criteria:	4	3	2	1
Basic electrical troubleshooting	4	3	2	1
Condenser fan, contactor troubleshooting	4	3	2	1
Compressor troubleshooting	4	3	2	1
Correction of no cooling complaint	4	3	2	1

EVALUATOR'S COMMENTS: _____

PERFORMANCE EVALUATION KEY

- 4 — **Skilled** — Can perform with no additional training.
- 3 — **Moderately skilled** — Has performed job during training program; limited additional additional training may be required.
- 2 — **Limited skill** — has performed job during training program; additional training is required to develop skill.
- 1 — **Unskilled** — Is familiar with process, but is unable to perform job.

(EVALUATOR NOTE: If an average score is needed to coincide with a competency profile, total the designated points in "Product Evaluation" and divide by the total number of criteria.)

**HEAT PUMP SYSTEMS
UNIT XIV**

PRACTICAL TEST #5

**JOB SHEET #5 — TROUBLESHOOT A HEAT PUMP
OUTDOOR SECTION ON AN "INSUFFICIENT
COOLING" COMPLAINT**

Student's name _____ Date _____

Evaluator's name _____ Attempt no. _____

Student instructions: When you are ready to perform this task, ask your instructor to observe the procedure and complete this form. All items listed under "Process Evaluation" must receive a "yes" for you to receive an overall performance evaluation.

PROCESS EVALUATION

(EVALUATOR NOTE: Place a check mark in the "Yes" or "No" blanks to designate whether or not the student has satisfactorily achieved each step in this procedure. If the student is unable to achieve this competency, have the student review the materials and try again.)

The student:	YES	NO
1. Installed gauge manifold and used proper charging table to check operating pressures.	<input type="checkbox"/>	<input type="checkbox"/>
2. Checked compressor valves, reversing valve, and check valve with proper procedures.	<input type="checkbox"/>	<input type="checkbox"/>
3. Confirmed reversing valve has enough differential pressure to switch modes.	<input type="checkbox"/>	<input type="checkbox"/>
4. Verified sticking contacts are not causing supplemental heat to come on.	<input type="checkbox"/>	<input type="checkbox"/>
5. Corrected "insufficient cooling" complaint.	<input type="checkbox"/>	<input type="checkbox"/>

Evaluator's comments: _____

JOB SHEET #5 PRACTICAL TEST

PRODUCT EVALUATION

(EVALUATOR NOTE: Rate the student on the following criteria by circling the appropriate numbers. Each item must be rated at least a "3" for mastery to be demonstrated. (See performance evaluation key below.) If the student is unable to demonstrate mastery, student materials should be reviewed and another test procedure must be submitted for evaluation.)

Criteria:

Operating pressures check	4	3	2	1
Compressor, reversing and check valve checks	4	3	2	1
Improper supplemental heat check	4	3	2	1
Correction of insufficient cooling complaint	4	3	2	1

EVALUATOR'S COMMENTS: _____

PERFORMANCE EVALUATION KEY

- 4 — **Skilled** — Can perform with no additional training.
 3 — **Moderately skilled** — Has performed job during training program; limited additional training may be required.
 2 — **Limited skill** — has performed job during training program; additional training is required to develop skill.
 1 — **Unskilled** — Is familiar with process, but is unable to perform job.

(EVALUATOR NOTE: If an average score is needed to coincide with a competency profile, total the designated points in "Product Evaluation" and divide by the total number of criteria.)

HEAT PUMP SYSTEMS UNIT XIV

PRACTICAL TEST #6

JOB SHEET #6 — PERFORM MAINTENANCE ON THE OUTDOOR SECTION ON A HEAT PUMP

Student's name _____ Date _____

Evaluator's name _____ Attempt no. _____

Student instructions: When you are ready to perform this task, ask your instructor to observe the procedure and complete this form. All items listed under "Process Evaluation" must receive a "yes" for you to receive an overall performance evaluation.

PROCESS EVALUATION

(EVALUATOR NOTE: Place a check mark in the "Yes" or "No" blanks to designate whether or not the student has satisfactorily achieved each step in this procedure. If the student is unable to achieve this competency, have the student review the materials and try again.)

The student:	YES	NO
1. Checked installation and elevation of outdoor section.	<input type="checkbox"/>	<input type="checkbox"/>
2. Lubricated fan motor to specifications.	<input type="checkbox"/>	<input type="checkbox"/>
3. Visually inspected control components.	<input type="checkbox"/>	<input type="checkbox"/>
4. Inspected and cleaned outdoor coil.	<input type="checkbox"/>	<input type="checkbox"/>
5. Connected gauges to proper ports.	<input type="checkbox"/>	<input type="checkbox"/>
6. Checked crankcase heater amp draw and operating pressures.	<input type="checkbox"/>	<input type="checkbox"/>
7. Checked amp draw of outdoor fan motor against nameplate specifications.	<input type="checkbox"/>	<input type="checkbox"/>
8. Checked amp draw of compressor against nameplate specifications.	<input type="checkbox"/>	<input type="checkbox"/>

Evaluator's comments: _____

JOB SHEET #6 PRACTICAL TEST

PRODUCT EVALUATION

(EVALUATOR NOTE: Rate the student on the following criteria by circling the appropriate numbers. Each item must be rated at least a "3" for mastery to be demonstrated. (See performance evaluation key below.) If the student is unable to demonstrate mastery, student materials should be reviewed and another test procedure must be submitted for evaluation.)

Criteria:

Installation and elevation check	4	3	2	1
Fan motor service	4	3	2	1
Crankcase heater operation check	4	3	2	1
Outdoor fan and compressor amp draw check	4	3	2	1

EVALUATOR'S COMMENTS: _____

PERFORMANCE EVALUATION KEY

- 4 — **Skilled** — Can perform with no additional training.
- 3 — **Moderately skilled** — Has performed job during training program; limited additional additional training may be required.
- 2 — **Limited skill** — has performed job during training program; additional training is required to develop skill.
- 1 — **Unskilled** — Is familiar with process, but is unable to perform job.

(EVALUATOR NOTE: If an average score is needed to coincide with a competency profile, total the designated points in "Product Evaluation" and divide by the total number of criteria.)

HEAT PUMP SYSTEMS UNIT XIV

PRACTICAL TEST #7

JOB SHEET #7 — TROUBLESHOOT SUPPLEMENTAL HEAT ON A HEAT PUMP

Student's name _____ Date _____

Evaluator's name _____ Attempt no. _____

Student instructions: When you are ready to perform this task, ask your instructor to observe the procedure and complete this form. All items listed under "Process Evaluation" must receive a "yes" for you to receive an overall performance evaluation.

PROCESS EVALUATION

(EVALUATOR NOTE: Place a check mark in the "Yes" or "No" blanks to designate whether or not the student has satisfactorily achieved each step in this procedure. If the student is unable to achieve this competency, have the student review the materials and try again.)

The student:	YES	NO
1. Checked for continuity and grounded heating elements.	<input type="checkbox"/>	<input type="checkbox"/>
2. Checked contactors and sequencers for continuity.	<input type="checkbox"/>	<input type="checkbox"/>
3. Checked continuity and grounding of blower power circuit.	<input type="checkbox"/>	<input type="checkbox"/>
4. Checked continuity of fan relay coil circuit.	<input type="checkbox"/>	<input type="checkbox"/>
5. Checked resistance on primary and secondary windings of low voltage transformer.	<input type="checkbox"/>	<input type="checkbox"/>
6. Checked amp draw of each heater.	<input type="checkbox"/>	<input type="checkbox"/>
7. Verified proper heater operation.	<input type="checkbox"/>	<input type="checkbox"/>

Evaluator's comments: _____

JOB SHEET #7 PRACTICAL TEST

PRODUCT EVALUATION

(EVALUATOR NOTE: Rate the student on the following criteria by circling the appropriate numbers. Each item must be rated at least a "3" for mastery to be demonstrated. (See performance evaluation key below.) If the student is unable to demonstrate mastery, student materials should be reviewed and another test procedure must be submitted for evaluation.)

Criteria: _____

Basic continuity and grounding check	4	3	2	1
Blower power circuit check	4	3	2	1
Low voltage transformer windings check	4	3	2	1
Individual heater amp draw check	4	3	2	1

EVALUATOR'S COMMENTS: _____

PERFORMANCE EVALUATION KEY	
4 —	Skilled — Can perform with no additional training.
3 —	Moderately skilled — Has performed job during training program; limited additional additional training may be required.
2 —	Limited skill — has performed job during training program; additional training is required to develop skill.
1 —	Unskilled — Is familiar with process, but is unable to perform job.

(EVALUATOR NOTE: If an average score is needed to coincide with a competency profile, total the designated points in "Product Evaluation" and divide by the total number of criteria.)

HEAT PUMP SYSTEMS UNIT XIV

PRACTICAL TEST #8

JOB SHEET #8 — PERFORM MAINTENANCE ON HEAT PUMP SUPPLEMENTAL HEATING

Student's name _____ Date _____

Evaluator's name _____ Attempt no. _____

Student instructions: When you are ready to perform this task, ask your instructor to observe the procedure and complete this form. All items listed under "Process Evaluation" must receive a "yes" for you to receive an overall performance evaluation.

PROCESS EVALUATION

(EVALUATOR NOTE: Place a check mark in the "Yes" or "No" blanks to designate whether or not the student has satisfactorily achieved each step in this procedure. If the student is unable to achieve this competency, have the student review the materials and try again.)

The student:	YES	NO
1. Serviced blower section.	<input type="checkbox"/>	<input type="checkbox"/>
2. Recorded fan motor amp draw with heater strips energized.	<input type="checkbox"/>	<input type="checkbox"/>
3. Recorded voltage and amp draw as sequencers closed heater circuits.	<input type="checkbox"/>	<input type="checkbox"/>
4. Compared full-load amps with heater nameplate ratings.	<input type="checkbox"/>	<input type="checkbox"/>
5. Measured return and supply air temperatures.	<input type="checkbox"/>	<input type="checkbox"/>
6. Recorded temperature rise through indoor section.	<input type="checkbox"/>	<input type="checkbox"/>
7. Verified proper operation of supplemental heating.	<input type="checkbox"/>	<input type="checkbox"/>

Evaluator's comments: _____

JOB SHEET #8 PRACTICAL TEST

PRODUCT EVALUATION

(EVALUATOR NOTE: Rate the student on the following criteria by circling the appropriate numbers. Each item must be rated at least a "3" for mastery to be demonstrated. (See performance evaluation key below.) If the student is unable to demonstrate mastery, student materials should be reviewed and another test procedure must be submitted for evaluation.)

Criteria: _____

Blower section service	4	3	2	1
Nameplate check of heat full-load amp draw	4	3	2	1
Return and supply air measurements	4	3	2	1
Temperature rise measurement	4	3	2	1

EVALUATOR'S COMMENTS: _____

PERFORMANCE EVALUATION KEY

- 4 — **Skilled** — Can perform with no additional training.
- 3 — **Moderately skilled** — Has performed job during training program; limited additional additional training may be required.
- 2 — **Limited skill** — has performed job during training program; additional training is required to develop skill.
- 1 — **Unskilled** — Is familiar with process, but is unable to perform job.

(EVALUATOR NOTE: If an average score is needed to coincide with a competency profile, total the designated points in "Product Evaluation" and divide by the total number of criteria.)

HEAT PUMP SYSTEMS UNIT XIV

PRACTICAL TEST #9

JOB SHEET #9 — TROUBLESHOOT A HEAT PUMP ON A "NO HEAT" COMPLAINT WHEN THE COMPRESSOR WILL NOT RUN

Student's name _____ Date _____

Evaluator's name _____ Attempt no. _____

Student instructions: When you are ready to perform this task, ask your instructor to observe the procedure and complete this form. All items listed under "Process Evaluation" must receive a "yes" for you to receive an overall performance evaluation.

PROCESS EVALUATION

(EVALUATOR NOTE: Place a check mark in the "Yes" or "No" blanks to designate whether or not the student has satisfactorily achieved each step in this procedure. If the student is unable to achieve this competency, have the student review the materials and try again.)

The student:	YES	NO
1. Completed open contactor check.	<input type="checkbox"/>	<input type="checkbox"/>
2. Completed closed contactor check.	<input type="checkbox"/>	<input type="checkbox"/>
3. Checked for loose compressor leads.	<input type="checkbox"/>	<input type="checkbox"/>
4. Checked for open, shorted, or grounded compressor windings.	<input type="checkbox"/>	<input type="checkbox"/>
5. Checked compressor overload.	<input type="checkbox"/>	<input type="checkbox"/>
6. Corrected "no heat" complaint.	<input type="checkbox"/>	<input type="checkbox"/>

Evaluator's comments: _____

JOB SHEET #9 PRACTICAL TEST

PRODUCT EVALUATION

(EVALUATOR NOTE: Rate the student on the following criteria by circling the appropriate numbers. Each item must be rated at least a "3" for mastery to be demonstrated. (See performance evaluation key below.) If the student is unable to demonstrate mastery, student materials should be reviewed and another test procedure must be submitted for evaluation.)

Criteria: _____

Contactors troubleshooting	4	3	2	1
-------------------------------	---	---	---	---

Compressor leads troubleshooting	4	3	2	1
-------------------------------------	---	---	---	---

Compressor windings troubleshooting	4	3	2	1
--	---	---	---	---

Verification of proper overload operation	4	3	2	1
---	---	---	---	---

EVALUATOR'S COMMENTS: _____

PERFORMANCE EVALUATION KEY

- | |
|---|
| <p>4 — Skilled — Can perform with no additional training.</p> <p>3 — Moderately skilled — Has performed job during training program; limited additional additional training may be required.</p> <p>2 — Limited skill — has performed job during training program; additional training is required to develop skill.</p> <p>1 — Unskilled — Is familiar with process, but is unable to perform job.</p> |
|---|

(EVALUATOR NOTE: If an average score is needed to coincide with a competency profile, total the designated points in "Product Evaluation" and divide by the total number of criteria.)

HEAT PUMP SYSTEMS UNIT XIV

PRACTICAL TEST #10

JOB SHEET #10 — TROUBLESHOOT A HEAT PUMP ON A "NO HEAT" COMPLAINT WHEN THE COMPRESSOR RUNS BUT CYCLES ON COMPRESSOR OVERLOAD

Student's name _____ Date _____

Evaluator's name _____ Attempt no. _____

Student instructions: When you are ready to perform this task, ask your instructor to observe the procedure and complete this form. All items listed under "Process Evaluation" must receive a "yes" for you to receive an overall performance evaluation.

PROCESS EVALUATION

(EVALUATOR NOTE: Place a check mark in the "Yes" or "No" blanks to designate whether or not the student has satisfactorily achieved each step in this procedure. If the student is unable to achieve this competency, have the student review the materials and try again.)

The student:	YES	NO
1. Verified indoor coil free of dirt and debris.	<input type="checkbox"/>	<input type="checkbox"/>
2. Checked for damage or malfunction of reversing valve.	<input type="checkbox"/>	<input type="checkbox"/>
3. Checked for restriction in discharge line.	<input type="checkbox"/>	<input type="checkbox"/>
4. Checked for system undercharge or overcharge.	<input type="checkbox"/>	<input type="checkbox"/>
5. Checked for malfunction in run capacitor.	<input type="checkbox"/>	<input type="checkbox"/>
6. Checked high load condition.	<input type="checkbox"/>	<input type="checkbox"/>
7. Checked high pressure control.	<input type="checkbox"/>	<input type="checkbox"/>
8. Corrected "no heat" complaint.	<input type="checkbox"/>	<input type="checkbox"/>

Evaluator's comments: _____

JOB SHEET #10 PRACTICAL TEST

PRODUCT EVALUATION

(EVALUATOR NOTE: Rate the student on the following criteria by circling the appropriate numbers. Each item must be rated at least a "3" for mastery to be demonstrated. (See performance evaluation key below.) If the student is unable to demonstrate mastery, student materials should be reviewed and another test procedure must be submitted for evaluation.)

Criteria: _____

Indoor coil inspection	4	3	2	1
Reversing valve check	4	3	2	1
Charging check	4	3	2	1
Complaint correction	4	3	2	1

EVALUATOR'S COMMENTS: _____

PERFORMANCE EVALUATION KEY	
4	— Skilled — Can perform with no additional training.
3	— Moderately skilled — Has performed job during training program; limited additional additional training may be required.
2	— Limited skill — has performed job during training program; additional training is required to develop skill.
1	— Unskilled — Is familiar with process, but is unable to perform job.

(EVALUATOR NOTE: If an average score is needed to coincide with a competency profile, total the designated points in "Product Evaluation" and divide by the total number of criteria.)

HEAT PUMP SYSTEMS UNIT XIV

PRACTICAL TEST #11

JOB SHEET #11 — TROUBLESHOOT A HEAT PUMP ON AN "INSUFFICIENT HEAT" COMPLAINT WHEN THE COMPRESSOR WILL RUN

Student's name _____ Date _____

Evaluator's name _____ Attempt no. _____

Student instructions: When you are ready to perform this task, ask your instructor to observe the procedure and complete this form. All items listed under "Process Evaluation" must receive a "yes" for you to receive an overall performance evaluation.

PROCESS EVALUATION

(EVALUATOR NOTE: Place a check mark in the "Yes" or "No" blanks to designate whether or not the student has satisfactorily achieved each step in this procedure. If the student is unable to achieve this competency, have the student review the materials and try again.)

The student:	YES	NO
1. Completed troubleshooting for stopped outdoor fan as needed.	<input type="checkbox"/>	<input type="checkbox"/>
2. Completed troubleshooting for running outdoor fan as needed.	<input type="checkbox"/>	<input type="checkbox"/>
3. Checked outdoor coil and strainer.	<input type="checkbox"/>	<input type="checkbox"/>
4. Checked defrost controls.	<input type="checkbox"/>	<input type="checkbox"/>
5. Checked strip heaters and strip heater relays.	<input type="checkbox"/>	<input type="checkbox"/>
6. Checked power circuit to heater elements.	<input type="checkbox"/>	<input type="checkbox"/>
7. Checked for broken heater elements.	<input type="checkbox"/>	<input type="checkbox"/>
8. Checked high limit for proper operation.	<input type="checkbox"/>	<input type="checkbox"/>

Evaluator's comments: _____

JOB SHEET #11 PRACTICAL TEST

PRODUCT EVALUATION

(EVALUATOR NOTE: Rate the student on the following criteria by circling the appropriate numbers. Each item must be rated at least a "3" for mastery to be demonstrated. (See performance evaluation key below.) If the student is unable to demonstrate mastery, student materials should be reviewed and another test procedure must be submitted for evaluation.)

Criteria: _____

Outdoor fan troubleshooting	4	3	2	1
Outdoor coil and strainer troubleshooting	4	3	2	1
Defrost controls operation verification	4	3	2	1
Strip heater troubleshooting	4	3	2	1

EVALUATOR'S COMMENTS: _____

PERFORMANCE EVALUATION KEY	
4 —	Skilled — Can perform with no additional training.
3 —	Moderately skilled — Has performed job during training program; limited additional additional training may be required.
2 —	Limited skill — has performed job during training program; additional training is required to develop skill.
1 —	Unskilled — Is familiar with process, but is unable to perform job.

(EVALUATOR NOTE: If an average score is needed to coincide with a competency profile, total the designated points in "Product Evaluation" and divide by the total number of criteria.)

770

**HEAT PUMP SYSTEMS
UNIT XIV**

PRACTICAL TEST #12

**JOB SHEET #12 — CHECK OPERATION OF AN ESSEX SOLID STATE
TIME-TEMPERATURE DEFROST CONTROL**

Student's name _____ Date _____

Evaluator's name _____ Attempt no. _____

Student instructions: When you are ready to perform this task, ask your instructor to observe the procedure and complete this form. All items listed under "Process Evaluation" must receive a "yes" for you to receive an overall performance evaluation.

PROCESS EVALUATION

(EVALUATOR NOTE: Place a check mark in the "Yes" or "No" blanks to designate whether or not the student has satisfactorily achieved each step in this procedure. If the student is unable to achieve this competency, have the student review the materials and try again.)

The student:	YES	NO
1. Prepared jumper wires to properly accelerate the timing cycle.	<input type="checkbox"/>	<input type="checkbox"/>
2. Jumpered defrost sensor and checked unit cycling in and out of defrost mode.	<input type="checkbox"/>	<input type="checkbox"/>
3. Prepared ice bath and warm-water baths properly.	<input type="checkbox"/>	<input type="checkbox"/>
4. Checked timing with sensor in cold water bath.	<input type="checkbox"/>	<input type="checkbox"/>
5. Checked timing with sensor in warm water bath.	<input type="checkbox"/>	<input type="checkbox"/>
6. Verified time-temperature control operation.	<input type="checkbox"/>	<input type="checkbox"/>

Evaluator's comments: _____

771

JOB SHEET #12 PRACTICAL TEST

PRODUCT EVALUATION

(EVALUATOR NOTE: Rate the student on the following criteria by circling the appropriate numbers. Each item must be rated at least a "3" for mastery to be demonstrated. (See performance evaluation key below.) If the student is unable to demonstrate mastery, student materials should be reviewed and another test procedure must be submitted for evaluation.)

Criteria: _____

Use of jumper wires
to accelerate
timing cycle

4 3 2 1

Ice and warm bath
preparation

4 3 2 1

Cold water/warm
weather sensor
verification

4 3 2 1

Time-temperature
defrost control
verification

4 3 2 1

EVALUATOR'S COMMENTS: _____

PERFORMANCE EVALUATION KEY	
4	Skilled — Can perform with no additional training.
3	Moderately skilled — Has performed job during training program; limited additional additional training may be required.
2	Limited skill — has performed job during training program; additional training is required to develop skill.
1	Unskilled — Is familiar with process, but is unable to perform job.

(EVALUATOR NOTE: If an average score is needed to coincide with a competency profile, total the designated points in "Product Evaluation" and divide by the total number of criteria.)

772

HEAT PUMP SYSTEMS UNIT XIV

PRACTICAL TEST #13

JOB SHEET #13 — CHECK OPERATION OF A RANCO E-15 MECHANICAL TIME-TEMPERATURE DEFROST CONTROL

Student's name _____ Date _____

Evaluator's name _____ Attempt no. _____

Student instructions: When you are ready to perform this task, ask your instructor to observe the procedure and complete this form. All items listed under "Process Evaluation" must receive a "yes" for you to receive an overall performance evaluation.

PROCESS EVALUATION

(EVALUATOR NOTE: Place a check mark in the "Yes" or "No" blanks to designate whether or not the student has satisfactorily achieved each step in this procedure. If the student is unable to achieve this competency, have the student review the materials and try again.)

The student:	YES	NO
1. Made proper motor inspection.	<input type="checkbox"/>	<input type="checkbox"/>
2. Made proper cam inspection.	<input type="checkbox"/>	<input type="checkbox"/>
3. Placed cam follower in initiation notch.	<input type="checkbox"/>	<input type="checkbox"/>
4. Verified operation by moving the diaphragm/bulb assembly.	<input type="checkbox"/>	<input type="checkbox"/>
5. Checked terminals 1, 2, and 3 for proper continuity.	<input type="checkbox"/>	<input type="checkbox"/>
6. Prepared ice bath properly.	<input type="checkbox"/>	<input type="checkbox"/>
7. Checked operation at 28°F.	<input type="checkbox"/>	<input type="checkbox"/>
8. Checked operation above 55°F.	<input type="checkbox"/>	<input type="checkbox"/>
9. Verified operation of control.	<input type="checkbox"/>	<input type="checkbox"/>

Evaluator's comments: _____

JOB SHEET #13 PRACTICAL TEST

PRODUCT EVALUATION

(EVALUATOR NOTE: Rate the student on the following criteria by circling the appropriate numbers. Each item must be rated at least a "3" for mastery to be demonstrated. (See performance evaluation key below.) If the student is unable to demonstrate mastery, student materials should be reviewed and another test procedure must be submitted for evaluation.)

Criteria: _____

Initial voltage check	4	3	2	1
Motor and cam inspection	4	3	2	1
Ice bath preparation and use	4	3	2	1
Low and high temperature operation verification	4	3	2	1

EVALUATOR'S COMMENTS: _____

PERFORMANCE EVALUATION KEY

- 4 — **Skilled** — Can perform job with no additional training.
- 3 — **Moderately skilled** — Has performed job during training program; limited additional training may be required.
- 2 — **Limited skill** — Has performed job during training program; additional training is required to develop skill.
- 1 — **Unskilled** — Is familiar with process, but is unable to perform job.

(EVALUATOR NOTE: If an average score is needed to coincide with a competency profile, total the designated points in "Product Evaluation" and divide by the total number of criteria.)

77

HEAT PUMP SYSTEMS UNIT XIV

PRACTICAL TEST #14

JOB SHEET #14 — CHECK OPERATION OF AN ESSEX 149-600 SOLID STATE DEMAND DEFROST CONTROL

Student's name _____ Date _____

Evaluator's name _____ Attempt no. _____

Student instructions: When you are ready to perform this task, ask your instructor to observe the procedure and complete this form. All items listed under "Process Evaluation" must receive a "yes" for you to receive an overall performance evaluation.

PROCESS EVALUATION

(EVALUATOR NOTE: Place a check mark in the "Yes" or "No" blanks to designate whether or not the student has satisfactorily achieved each step in this procedure. If the student is unable to achieve this competency, have the student review the materials and try again.)

The student:	YES	NO
1. Set up system and made temperature check.	<input type="checkbox"/>	<input type="checkbox"/>
2. Jumpered pins as required to ready system for defrost.	<input type="checkbox"/>	<input type="checkbox"/>
3. Jumpered INIT pins to switch unit into defrost.	<input type="checkbox"/>	<input type="checkbox"/>
4. Checked conditions for reversing the defrost cycle.	<input type="checkbox"/>	<input type="checkbox"/>
5. Removed jumpers and gauges.	<input type="checkbox"/>	<input type="checkbox"/>
6. Verified proper operation of the demand defrost control.	<input type="checkbox"/>	<input type="checkbox"/>
7. Replaced control unit (if required).	<input type="checkbox"/>	<input type="checkbox"/>

Evaluator's comments: _____

JOB SHEET #14 PRACTICAL TEST

PRODUCT EVALUATION

(EVALUATOR NOTE: Rate the student on the following criteria by circling the appropriate numbers. Each item must be rated at least a "3" for mastery to be demonstrated. (See performance evaluation key below.) If the student is unable to demonstrate mastery, student materials should be reviewed and another test procedure must be submitted for evaluation.)

Criteria:

Initial voltage verification	4	3	2	1
Jumpering to ready defrost mode	4	3	2	1
Jumpering to initiate defrost cycle	4	3	2	1
Verification of control operation	4	3	2	1

EVALUATOR'S COMMENTS: _____

PERFORMANCE EVALUATION KEY

- 4 — **Skilled** — Can perform job with no additional training.
- 3 — **Moderately skilled** — Has performed job during training program; limited additional training may be required.
- 2 — **Limited skill** — Has performed job during training program; additional training is required to develop skill.
- 1 — **Unskilled** — Is familiar with process, but is unable to perform job.

(EVALUATOR NOTE: If an average score is needed to coincide with a competency profile, total the designated points in "Product Evaluation" and divide by the total number of criteria.)

HEAT PUMP SYSTEMS UNIT XIV

TEST

Name _____ Score _____

1. Match terms related to heat pump systems with their correct definitions.

- | | | | |
|-------|---|-----|------------------------------|
| _____ | a. A refrigerated air conditioning system with a valve to reverse the action or direction of heat transfers | 1. | Defrost cycle |
| _____ | b. A valve used to reverse the action or direction of heat transfers by routing refrigerant | 2. | Ground loop |
| _____ | c. Allows refrigerant to flow in one direction | 3. | Heat pump |
| _____ | d. A cycle used to melt frost accumulation from the outside coil | 4. | Supplemental heat |
| _____ | e. A heat pump operated with a fossil fuel furnace | 5. | Check valve |
| _____ | f. Uses water or other liquid as the heat exchanger medium | 6. | Water source heat pump |
| _____ | g. A drier designed to work with flow in either direction | 7. | Reversing valve |
| _____ | h. A sealed and pressurized loop of water or anti-freeze solution circulated below the earth's surface | 8. | Bi-directional flow drier |
| _____ | i. Usually electric strip heaters to add heat when the unit cannot maintain the indoor temperature desired | 9. | Fossil fuel/add on heat pump |
| _____ | j. Monitors liquid flow and shuts down system when there is no liquid flow | 10. | Low ambient switch |
| _____ | k. Monitors water temperature and shuts down unit operation if water temperature gets too low | 11. | Plenum switch |
| _____ | l. Monitors outdoor temperature to deactivate a heat pump and switch to alternate heating when temperature goes below a given set point | 12. | Freeze thermostat |
| _____ | m. Monitors air temperature in the supply plenum in order to control activation of the furnace or heat pump in fossil fuel/heat pump add-on systems | 13. | Flow switch |

TEST

2. Identify heat pump configurations. Indicate in the following illustrations an air-to-air heat pump, a water-to-air heat pump, an air-to-water heat pump, and a water-to-water heat pump.

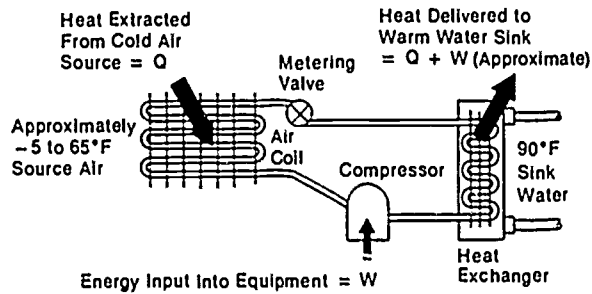

a. _____

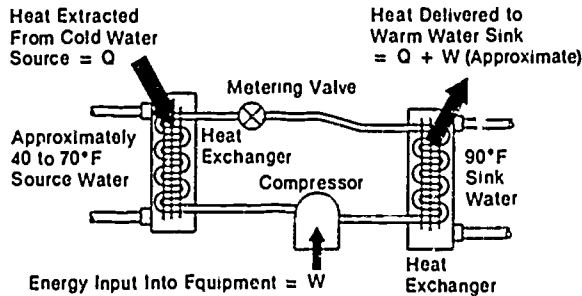

b. _____

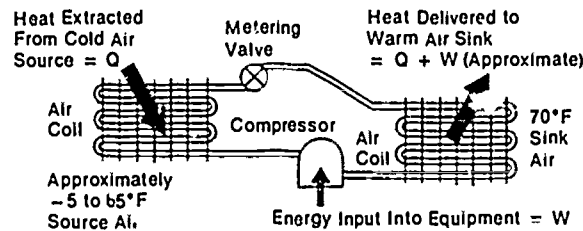

c. _____

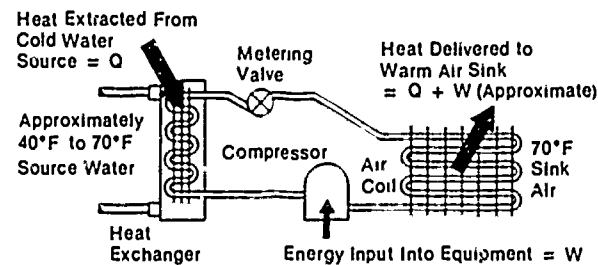

d. _____

TEST

3. Identify components of a heat pump. Write the component name beside the correct reference letter.

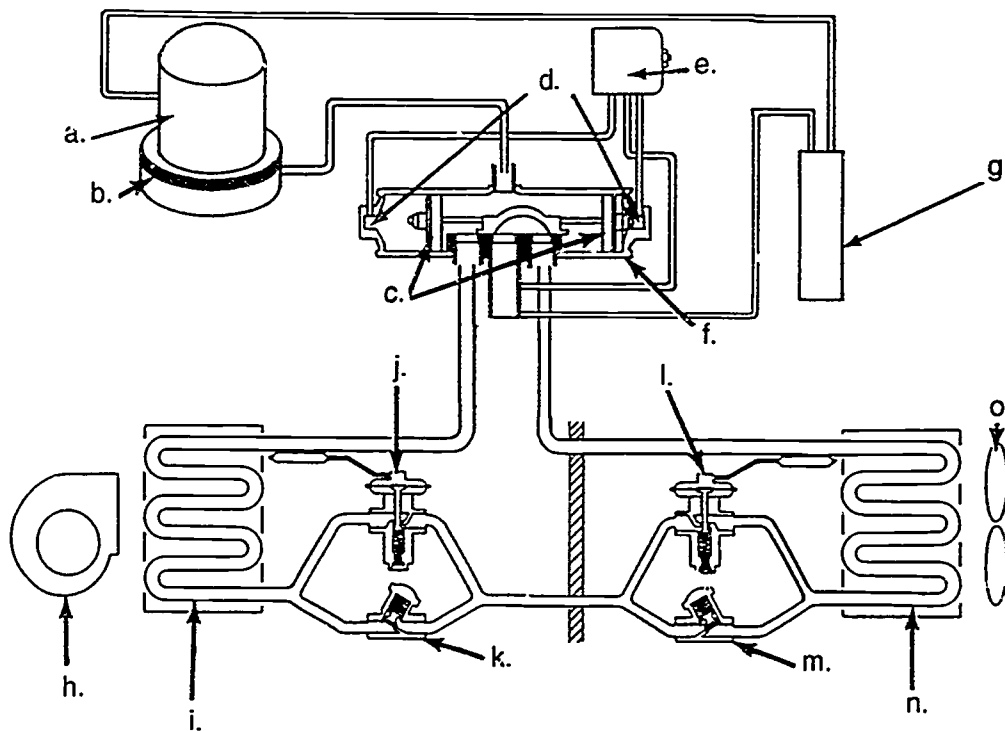

- a. _____
- b. _____
- c. _____
- d. _____
- e. _____
- f. _____
- g. _____
- h. _____

- i. _____
- j. _____
- k. _____
- l. _____
- m. _____
- n. _____
- o. _____

TEST

4. Identify components of a 4-way reversing valve. Match each component with its correct name.

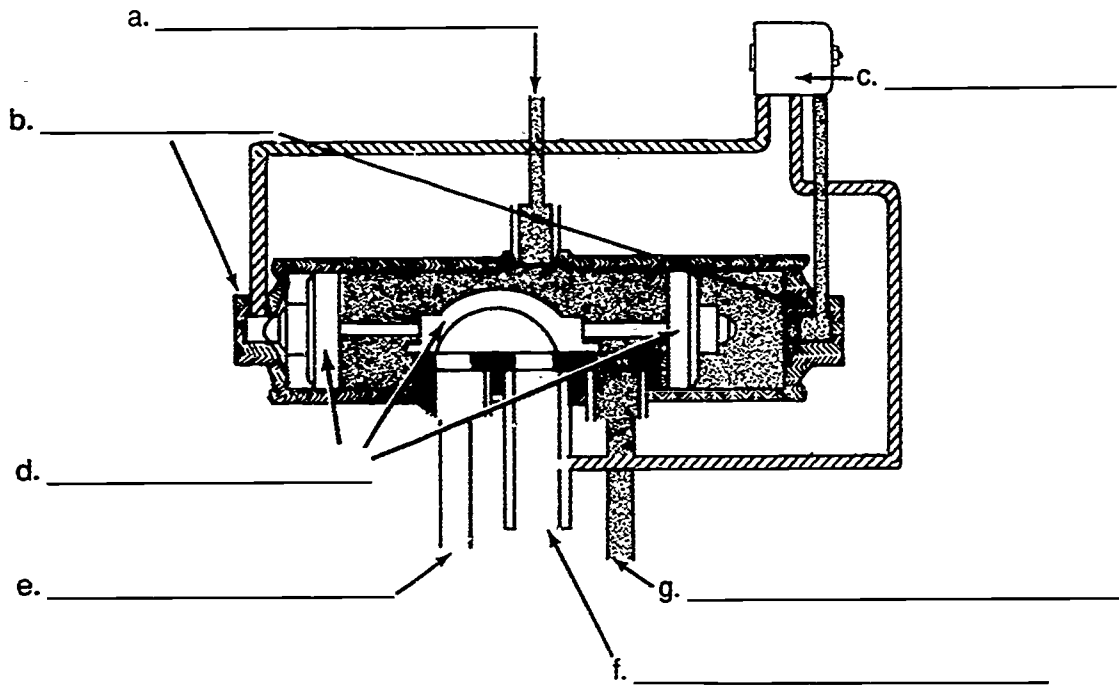

1. Connection to discharge line of compressor
2. Piston bleed ports
3. Connection to inside coil
4. Solenoid and activating device
5. Connection to suction line of compressor
6. Piston
7. Connection to outside coil

TEST

5. Differentiate between the operation of a 4-way reversing valve in the heating mode and cooling mode by placing an "X" beside the illustration of a 4-way reversing valve in the cooling mode.

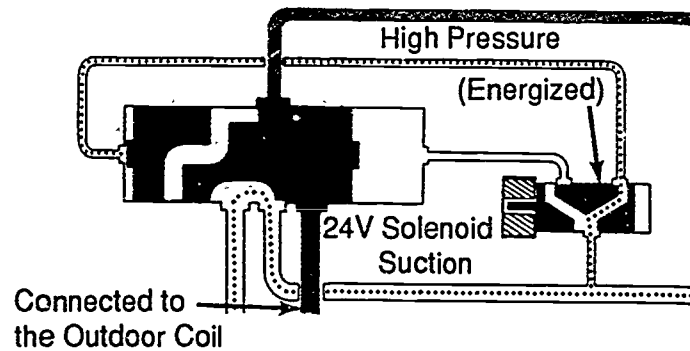

___ a.

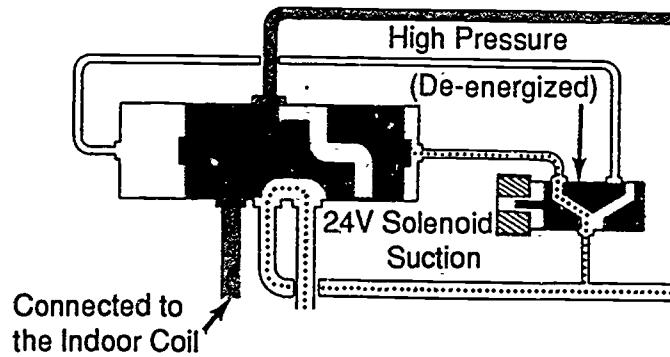

___ b.

TEST

6. Select true statements concerning metering devices and check valves. Place an "X" beside each true statement.
- a. A heat pump system with thermostatic expansion valve metering devices must have a check valve for each expansion valve.
 - b. In the cooling mode, an indoor check valve is closed and refrigerant flow is through the expansion valve while the outdoor check valve is open and the refrigerant bypasses the outdoor expansion valve.
 - c. In the heating mode, the indoor check valve opens bypassing the indoor metering device, and the outdoor check valve closes causing refrigerant to flow through the outdoor metering device.
 - d. The outdoor coil is then the heat dissipating coil and the indoor coil is the heat absorbing coil.
 - e. A heat pump with a flow check piston metering device is similar to a typical split-system air conditioner when the heat pump is in the cooling mode.
 - f. In the heating mode, a heat pump with flow check piston metering is like a typical split-system air conditioner except that the reversing valve has changed direction of refrigerant flow.
 - g. When the flow type check piston metering is used, there are separate check valves in the refrigerant circuit.
7. Select true statements concerning a heat pump in the defrost mode. Place an "X" beside each true statement.
- a. The defrost cycle is initiated by "time/temperature" or "demand" depending on the method.
 - b. The reversing valve operates and goes into a heating cycle.
 - c. Cool discharge gas from the compressor is routed to the outdoor coil.
 - d. Frost accumulation on the outdoor coil is melted.
 - e. The outside fan is de-energized to assist the melting process.
 - f. Some supplementary heat is energized to temper the cool air across the indoor coil during defrost.
 - g. After frost removal has been accomplished the cycle is terminated by the method used by the manufacturer.
 - h. The reversing valve changes flow back to the cooling cycle and the outdoor fan is energized.

TEST

8. Select true statements concerning methods of defrost initiation and termination. Place an "X" beside each statement that is true.

(NOTE: For a statement to be true, all parts of the statement should be true.)

___ a. Time/temperature mechanical

- 1) Initiates at preset time interval if coil temperature is below the "make point" of the sensing bulb
- 2) Terminates when coil temperature reaches the "break point"
- 3) Some controls have a maximum defrost time of 10 minutes and will automatically switch back to heating cycle.
- 4) Some units may use pressure switch instead of temperature sensing bulb.
- 5) Time intervals can be selected as local conditions require.

___ b. Time-/temperature, solid state

- 1) Solid state board used as the timing device
- 2) Bi-metal sensing device
- 3) Time intervals can be selected as local conditions require.

___ c. Demand defrost, solid state

- 1) Solid state control board
- 2) Coil sensor
- 3) Ambient air sensor

___ d. Demand defrost, air switch/temperature

- 1) Air pressure sensing tubes mounted to sense air pressure drop across the outdoor coil
- 2) Diaphragm operated micro-switch puts unit into defrost if frost or ice creates enough air pressure drop across the coil and the temperature sensing device is closed

TEST

9. Identify components of a heat pump indoor section. Write the component name in the appropriate blank.

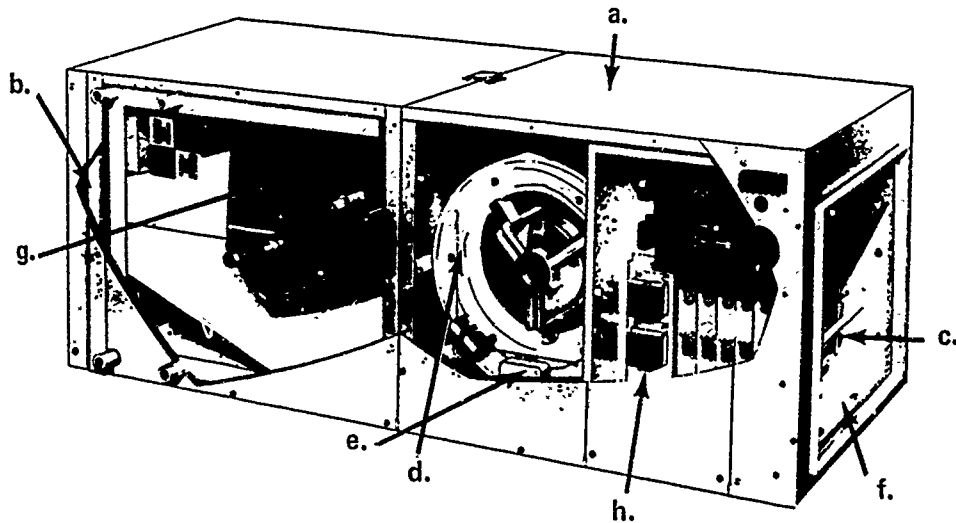

- | | |
|----------|----------|
| a. _____ | e. _____ |
| b. _____ | f. _____ |
| c. _____ | g. _____ |
| d. _____ | h. _____ |

10. Complete a list of component failures of heat pumps. List problems for given components.

- a. Check valve
- 1) _____
 - 2) _____
 - 3) _____

TEST

- b. Reversing valve
- 1) _____
 - 2) _____
11. Solve problems concerning the heat pump touch test. Select the best solution to each of the following.
- a. You're checking a heat pump. After a few minutes of operation in the heating mode, the line from the outdoor coil into the valve and the line from the valve to compressor suction both feel cool to the touch. You evaluate the reversing valve as _____.
 - 1) Having a problem in the suction line.
 - 2) Having a problem in the outdoor coil.
 - 3) Probably in good working order.
 - b. You're checking a heat pump. After a few minutes of operation in the cooling mode, the line from compressor discharge into the valve and the line from the valve to the outdoor coil both feel hot. You evaluate the reversing valve as _____.
 - 1) Probably in good working order.
 - 2) Having a problem in the indoor coil.
 - 3) Having a problem in the compressor discharge line.
 - c. You're checking a heat pump. After a few minutes of operation in the heating mode, all three tubes on the suction side of the valve feel hot to the touch. You evaluate the reversing valve as _____.
 - 1) Probably in good working order.
 - 2) Probably needs checking further.
 - 3) Probably having a piston stuck in mid-position.

TEST

12. Solve problems concerning special precautions for replacing reversing valves. Select the best solution to each of the following.
- a. A co-worker installing a replacement reversing valve picks up a hammer to tap it into place. There is a risk that _____.
- 1) The hammer blow could weaken the valve material.
 - 2) The hammer blow could dent or bend the valve.
 - 3) The hammer blow may place the valve too far into the suction line.
- b. A co-worker is brazing a line near a recently replaced reversing valve. To avoid heat damage to the reversing valve, the co-worker should _____.
- 1) Use a cold sealing process.
 - 2) Remove the valve until brazing is complete.
 - 3) Wrap the valve with a wet cloth and point the brazing flame away from the valve.
- c. A replacement reversing valve has been placed near a copper line that a co-worker is cleaning. To avoid any possible damage to the valve, the co-worker should _____.
- 1) Cover the valve so no foreign material can fall inside.
 - 2) Loosen the valve and remove it.
 - 3) Continue with cleaning the copper line.
13. Complete statements concerning special precautions for driers. Circle the material that best completes each statement.
- a. A suction drier (should probably) (must) be located between the compressor and the reversing valve.
- b. A bi-directional flow liquid line drier must be used if installed where (liquid flow is reversed) (a check valve is used).

TEST

14. Select true statements concerning guidelines for supplemental heating strips. Place an "X" beside each true statement.

- a. Usually installed in the outdoor section
- b. Should always be installed on the discharge side of the air handling equipment, downstream from the indoor coil
- c. Controls for strip heaters must be readily accessible
- d. Duct heater is seldom used

15. Select true statements concerning temperature controls. Place an "X" beside each true statement.

(NOTE: For a statement to be true, all parts of the statement must be true.)

- a. Room thermostat
 - 1) Usually two stage heating and single stage cooling
 - 2) Must be compatible with the heat pump control circuitry
 - 3) Usually equipped with "emergency heat" switch to put operation totally on supplemental form of heat
- b. Outdoor thermostat
 - 1) Senses outdoor ambient
 - 2) May be used to restrict or stage supplemental heaters

16. Select true statements concerning fossil fuel/add-on heat pumps. Place an "X" beside each true statement.

(NOTE: For a statement to be true, all parts of the statement must be true.)

- a. Heat pumps used at milder temperatures
- b. Furnace used at lower temperatures
- c. Heat pump uses fossil fuel furnace for indoor air handler
 - 1) Indoor coil usually on upstream side of heat exchanger
 - 2) Heat pump turned "off" when the furnace heat is "on"

TEST

17. Solve problems concerning water source heat pumps. Select the best solution to each of the following.
- a. A customer has heard that a pond can be used with a heat pump system. You need to explain to the customer _____.
 - 1) What an open-loop system is.
 - 2) What a closed-loop system is.
 - 3) What an air-to-air system is.
 - b. A customer wants to know what advantages a water source heat pump system would have. You need to point out that _____.
 - 1) Components in the system usually cost less.
 - 2) Components in the system are easier to service.
 - 3) The systems do not require an outdoor fan or a defrost cycle.
18. Complete statements concerning closed-loop/ground-source heat pumps. Circle the material that best completes each statement.
- a. Systems absorb heat from the earth during the (cooling) (heating) cycle.
 - b. Systems reject heat into the earth during the (heating) (cooling) cycle.
 - c. System configuration can be horizontal or vertical depending on (available land) (temperature zone).
 - d. System requires contacting utility companies before (drilling or trenching) (planning).
19. Complete statements concerning rules for good heat pump operation. Finish each statement with the appropriate material.
- a. Proper air flow to include:
 - 1) Correct _____.
 - 2) Keeping _____.
 - 3) Keeping _____.
 - b. System must have proper _____.

(NOTE: If the following activities have not been accomplished prior to the test, as you instructor when they should be completed.)

TEST

20. Trace operational circuits for a heat pump in the cooling mode. (Assignment Sheet #1)
21. Trace operational circuits for first stage heating in a heat pump. (Assignment Sheet #2)
22. Trace operational circuits for a heat pump in the defrost mode. (Assignment Sheet #3)
23. Trace operational circuits for second stage supplemental heat in a heat pump. (Assignment Sheet #4)
24. Trace operational circuits for a fossil fuel heat pump system in first stage heat mode above 45°F ambient outdoor. (Assignment Sheet #5)
25. Trace operational circuits for a fossil fuel heat pump system in first stage heat mode below 40°F ambient outdoor. (Assignment Sheet #6)
26. Demonstrate the ability to:
 - a. Wire a control system for a heat pump. (Job Sheet #1)
 - b. Troubleshoot a heat pump indoor section in the cooling mode. (Job Sheet #2)
 - c. Perform maintenance on an indoor section of a heat pump in the cooling mode. (Job Sheet #3)
 - d. Troubleshoot a heat pump on a "no cooling" complaint. (Job Sheet #4)
 - e. Troubleshoot a heat pump outdoor section on an "insufficient cooling" complaint. (Job Sheet #5)
 - f. Perform maintenance on the indoor section of a heat pump. (Job Sheet #6)
 - g. Troubleshoot supplemental heat on a heat pump. (Job Sheet #7)
 - h. Perform maintenance on heat pump supplemental heating. (Job Sheet #8)
 - i. Troubleshoot a heat pump on a "no heat" complaint when the compressor will not run. (Job Sheet #9)
 - j. Troubleshoot a heat pump on a "no heat" complaint when the compressor runs but cycles on compressor overload. (Job Sheet #10)
 - k. Troubleshoot a heat pump on an "insufficient heat" complaint when the compressor will run. (Job Sheet #11)
 - l. Check operation of an Essex solid state time-temperature defrost control. (Job Sheet #12)

TEST

- m. Check operation of a Ranco E-15 mechanical time-temperature defrost control. (Job Sheet #13)
- n. Check operation of an Essex 149-600 solid state demand defrost control. (Job Sheet #14)

037

HEAT PUMP SYSTEMS
UNIT XIV

ANSWERS TO TEST

1. a. 3 f. 6 k. 12
 b. 7 g. 8 l. 10
 c. 5 h. 2 m. 11
 d. 1 i. 4
 e. 9 j. 13
2. a. Air-to-water
 b. Water-to-water
 c. Air-to-air
 d. Water-to-air
3. a. Compressor i. Indoor refrigerant coil
 b. Crankcase heater j. Indoor metering device
 c. Piston k. Indoor check valve
 d. Piston bleed ports l. Outdoor metering device
 e. Solenoid m. Outdoor check valve
 f. 4-way reversing valve n. Outdoor refrigerant coil
 g. Accumulator o. Outdoor fan
 h. Indoor blower
4. a. 1 e. 3
 b. 2 f. 5
 c. 4 g. 7
 d. 6
5. a
6. a, b, d, e, f, g
7. a, d, e, f, g
8. a, b, c, d

ANSWERS TO TEST

9. a. Cabinet
 b. Filter and cold air inlet
 c. Heating elements of nichrome wire or tubular cased wire
 d. Blower assembly
 e. Blower and limit control switches
 f. Heat exchange chamber and warm air outlet
 g. Indoor coil
 h. Supplementary heat controls and sequencing relay
10. a. 1) May stick in open position
 2) May stick in closed position
 3) May stick partially open
 b. 1) Holding coil for solenoid may be open or shorted
 2) Piston may not shift position
11. a. 3)
 b. 1)
 c. 3) 2) is also acceptable
12. a. 2)
 b. 3)
 c. 1)
13. a. Must
 b. Liquid flow is reversed
14. b, c
15. a, b
16. a, b
17. a. 1)
 b. 3)
18. a. Heating
 b. Cooling
 c. Available land
 d. Drilling or trenching

ANSWERS TO TEST

19. a. 1) Duct design
2) Filters clean
3) Coils clean
b. Refrigerant charge
- 20.-25. Evaluated according to answers to assignment sheets
26. a. Evaluated according to criteria in Practical Test #1
b. Evaluated according to criteria in Practical Test #2
c. Evaluated according to criteria in Practical Test #3
d. Evaluated according to criteria in Practical Test #4
e. Evaluated according to criteria in Practical Test #5
f. Evaluated according to criteria in Practical Test #6
g. Evaluated according to criteria in Practical Test #7
h. Evaluated according to criteria in Practical Test #8
i. Evaluated according to criteria in Practical Test #9
j. Evaluated according to criteria in Practical Test #10
k. Evaluated according to criteria in Practical Test #11
l. Evaluated according to criteria in Practical Test #12
m. Evaluated according to criteria in Practical Test #13
n. Evaluated according to criteria in Practical Test #14

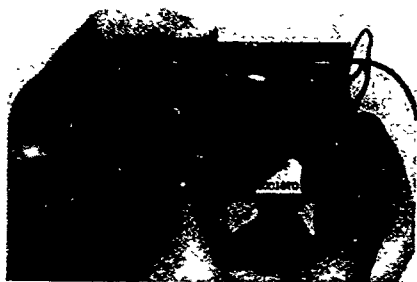

BALANCE POINTS UNIT XV

UNIT OBJECTIVE

After completion of this unit, the student should be able to plot balance points for a heat pump at given design conditions and physically set balance points on a system. These competencies will be demonstrated by completing the assignment and job sheets, and by scoring a minimum of 85 percent on the unit test.

SPECIFIC OBJECTIVES

After completion of this unit, the student should be able to:

1. Match terms related to balance points with their correct definitions.
2. Distinguish between the COP of a direct electrical heating element and the COP of a heat pump.
3. Determine the COP of a heat pump at a given design temperature.
4. Select true statements concerning balance points and their relation to COP.
5. Match balance points with typical stages in heating continuity.
6. Complete a list of factors needed to plot balance points.
7. Plot a heat pump performance curve from manufacturer's specifications.
8. Plot balance point #1 from given design conditions.
9. Plot additional balance points from given design conditions.
10. Select true statements concerning the procedure for sizing a heat pump on the cooling load.
11. List two advantages of controlled heating stages.
12. Select true statements concerning installation considerations related to heat pump performance.
13. Size a heat pump on the cooling load. (Assignment Sheet #1)

SPECIFIC OBJECTIVES

14. Plot balance points for a heat pump at given design conditions. (Assignment Sheet #2)
15. Locate equipment to obtain maximum COP from a heat pump. (Assignment Sheet #3)
16. Demonstrate the ability to set outdoor thermostats for proper staging of auxiliary heat. (Job Sheet #1)

**BALANCE POINTS
UNIT XV****SUGGESTED ACTIVITIES**

- A. Obtain additional materials and/or invite resource people to class to supplement/reinforce information provided in this unit of instruction.

(NOTE: This activity should be completed prior to the teaching of this unit.)

- E. Make transparencies from the transparency masters included with this unit.
- C. Provide students with objective sheet.
- D. Discuss unit and specific objectives.
- E. Provide students with information and assignment sheets.
- F. Discuss information and assignment sheets.

(NOTE: Use the transparencies as needed to enhance the information.)

- G. Provide students with job sheets.
- H. Discuss and demonstrate the procedures outlined in the job sheets.
- I. Integrate the following activities throughout the teaching of this unit:
1. Invite an electric utility representative to talk to the class concerning heat pump installations and a comparison of operating costs for heat pumps and other systems.
 2. Invite a local or area contractor who makes heat pump installations to discuss typical systems and balance points that are used in the area, and especially any variations in heat staging continuity.
 3. Invite a manufacturer's representative to demonstrate to the class how indoor and outdoor sections of heat pumps are matched, and how outdoor design conditions affect equipment selection, particularly supplementary heating.
 4. Meet individually with students to evaluate their progress through this unit of instruction, and indicate to them possible areas for improvement.

- J. Give test.
- K. Evaluate test.
- L. Reteach if necessary.

SUGGESTED ACTIVITIES**REFERENCES USED IN DEVELOPING THIS UNIT**

- A. *Heat Pump Design, Service and Application*. Dallas, TX 75240: Lennox Industries Inc., Education Department, 1979.
- B. Eckes, William, and Dan Fulkerson. *Air Conditioning and Refrigeration, Book Four* Stillwater, OK 74074: Mid-America Vocational Curriculum Consortium, Inc., 1981.
- C. *Heat Pump Split Systems*. Lavergne, TN 37086-1985: Heil-Quaker Corporation, 1989.
- D. Rutkowski, Hank. *Heat Pump Systems: Principles Applications, Manual H, Second Edition*. Washington, DC 20036: Air Conditioning Contractors of America, 1984.

**BALANCE POINTS
UNIT XV****INFORMATION SHEET****I. Terms and definitions**

- A. **Balance point** — The point, expressed in °F, where the heat pump capacity is equal to or balanced with the heat loss of the structure
- B. **Additional balance points** — Points beyond the initial balance point which indicate the most advantageous temperatures for energizing supplementary heating
- C. **Balance point number** — A system of identifying the initial balance point as balance point #1, and additional balance points as balance point #2, balance point #3, etc.
- D. **Supplementary heating** — Electrical heating strips programmed to energize in stages to compensate for reduced heat pump capacity as temperature drops
- E. **Economic balance point** — The point at which a heat pump/fossil fuel system is automatically switched from one energy source to an alternate energy source
- F. **COP** — Coefficient of performance, the ratio of heat output to heat input
- G. **HSPF (Heating Season Performance Factor)** — The total estimated heat output in BTUs for the entire heating season divided by the estimated total energy consumed

II. Comparison of direct electrical heating elements and heat pumps

- A. Ordinary direct heating elements have a COP of 1.0.
- 3. The COP of heat pump is always greater than 1.0. (Figure 1)

INFORMATION SHEET

FIGURE 1

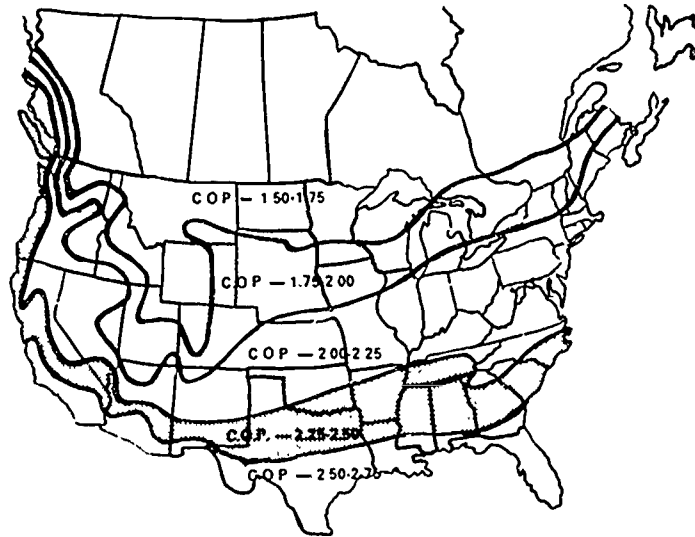

Courtesy Lennox Industries Inc.

III. How to determine the COP of a heat pump

- A. $\text{COP} = \text{Btuh output divided by Btuh input.}$

Example:
$$\text{COP} = \frac{\text{Btuh output (useable heat)}}{\text{Btuh input (heat paid for)}}$$

- B. When unit input is given in watts, the conversion factor of 3.413 should be used to convert watts to Btuh.

Example:
$$\text{COP} = \frac{\text{Btuh output}}{\text{Unit wattage} \times 3.413}$$

Using the formula, a unit with a 4,380 watt input and a 39,000 Btuh output would have a COP of 2.6 because $4,380 \times 3.413 = 14,948$ Btuh, or rounded off, 14,950 Btuh, and $39,000$ divided by $14,950 = 2.6$.

- C. COP has a direct relation to outdoor temperature, and COP will decline as outdoor temperature declines. (Figure 2)

INFORMATION SHEET

FIGURE 2

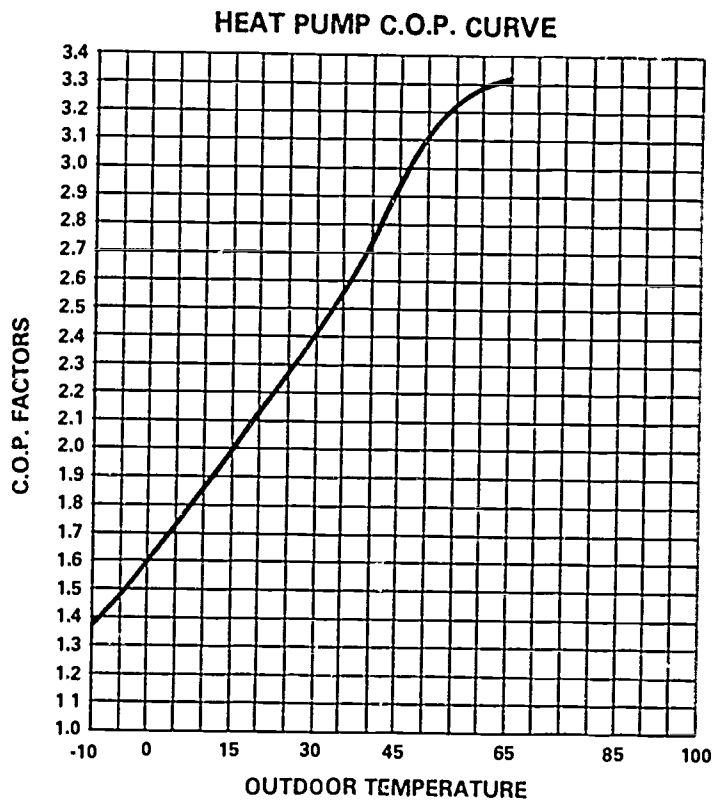

Courtesy Lennox Industries Inc.

IV. Balance points and their relation to COP

- A. When the COP of a heat pump drops, balance points maintain economical heating continuity in a conditioned space.
- B. Balance points promote maximum COP.
- C. Balance points assist in determining equipment size and amount of supplemental heat required.

(NOTE: When 100 percent capacity supplemental heat is installed it should be staged so that all stages will be energized only in the event of compressor failure.)

INFORMATION SHEET

- D. The economic balance point of a heat pump/fossil fuel system can be determined only after utility rates are known.

(NOTE: Some heat pump manufacturers set the point around 40°F to switch to fossil fuel. The crankcase heater may not be able to keep liquid from migrating to the compressor at lower temperatures during the "off" cycle of the compressor.)

V. Balance points and typical stages in heating continuity (Transparency 1)

- A. Balance point #1 — When outdoor temperature falls below this point, an indoor thermostat calls for second-stage heat and the first two heating elements will energize.
- B. Balance point #2 — When outdoor temperature continues to fall, an outdoor thermostat calls for third-stage heat and a third heating element is energized.
- C. Balance point #3 — When outdoor temperature continues to fall even more, a second outdoor thermostat calls for fourth-stage heat and a fourth heating element is energized.

(NOTE: This staging process is typical of balance points and heating continuity, but there are many variations depending on equipment, outdoor design temperature, and manufacturer's specifications.)

VI. Factors needed to plot balance points

- A. Performance curve based on Btuh of the heat pump
- B. Heat loss calculation for the structure — ACCA considers no heat required above 65°F to maintain 70°F (5 degree heating credit for internal gains in residential structures)
- C. Outside design temperature
- D. Inside design temperature

VII. Steps in plotting a heat pump performance curve

- A. Prepare a graph with capacity of heat pump and structure heat loss shown in thousands Btuh on the vertical axis; work with units of 5,000 Btuh starting with zero at the bottom.
- B. Complete the graph with outdoor dry bulb temperature ranging from -20°F to 80°F shown in units of 10 on the horizontal axis from left to right.

INFORMATION SHEET

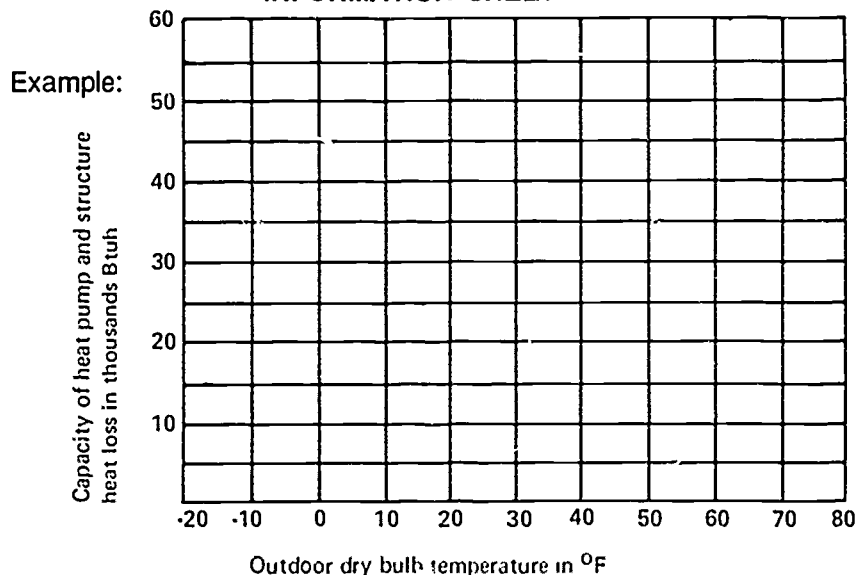

- C. From available manufacturer's specifications, transfer total Btuh output to the proper points on the chart and connect the points to show the performance curve.

Example:

Outdoor Temperature (Degree F)	Compressor Motor Watts Input	Total Output (Btuh)
65	2730	32,200
60	2540	29,900
55	2345	27,900
50	2180	25,700
45	2040	23,500
40	1900	21,200
35	1790	19,600
30	1705	18,300
25	1635	16,500
20	1555	15,000
15	1500	13,600
10	1430	11,900
5	1375	10,500
0	1310	9,100
-5	1250	7,800
-10	1195	6,700
-15	1130	6,100
-20	1060	5,700

1. Air-to-air heat pump performance depends on the temperature of the outside air.
2. Geothermal heat pump performance depends on entering water temperature instead of outdoor air temperature.

INFORMATION SHEET

Example:

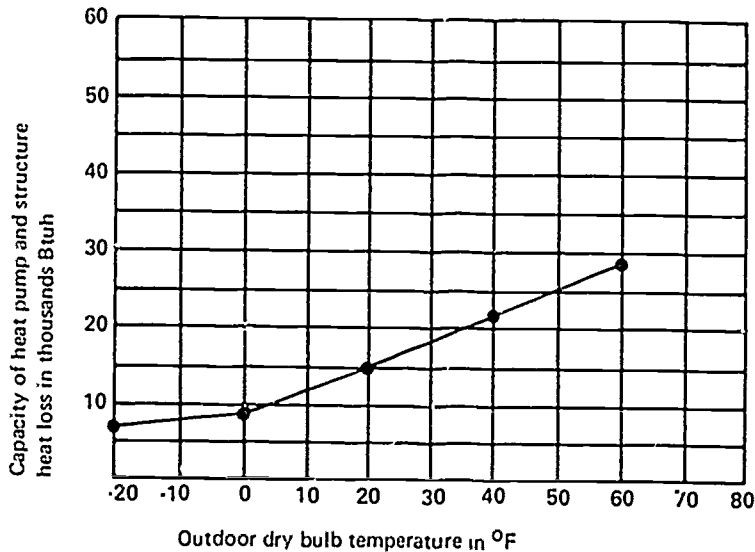

VIII. Steps in plotting balance point #1 (Transparency 2)

- A. On a graph showing the heat pump performance curve, locate the indoor design temperature of 70°F, subtract 5°F for internal gains and mark point "A" at 65°.
- B. Assume an outdoor design temperature of 10°F and a structure heat loss of 40,000 Btuh; sketch a vertical dotted line up from the 10°F point until it intersects the 40,000 Btuh line and mark it point B.
- C. Draw a solid diagonal line connecting points A and B.
- D. Balance point #1 is located at the point where the performance line and the heat loss line intersect; mark it point C.

IX. Steps in plotting additional balance points (Transparency 3)

- A. Assume the indoor thermostat at balance point #1 energizes two 2-kw strip heaters.

(NOTE: Heaters come in other increments also and would need to be plotted according to their capacity.)
- B. Draw a dotted vertical line up from the 37°F point until it goes to a point that represents 13,600 additional Btuh, and mark this as point D.

(NOTE: Remember the conversion factor, 1 kw = approximately 3,400 Btuh, so 4 kw = 13,600 Btuh.)

INFORMATION SHEET

- C. Draw a straight line from point D so that it runs parallel to the heat pump performance line and intersects the heat loss line, and mark this point E.
- D. Point E gives the temperature where balance point #2 should be.
- E. Assume the outdoor thermostat at balance point #2 energized another 2-kw strip heater.
- F. Draw a dotted vertical line up from the 26°F point until it goes to a point that represents 6,800 additional Btuh, and mark this point F.
- G. Draw a straight line from point F so that it runs parallel to the heat pump performance line and intersects the heat loss line, and mark this point G.
- H. Point G gives the temperature where balance point #3 should be.
- I. Assume the outdoor thermostat at balance point #3 energizes another 2-kw strip heater.
- J. Draw a dotted vertical line up from the 20°F point until it goes to a point that represents 6,800 additional Btuh, and mark this point H.
- K. Draw a straight line from point H so that it runs parallel to the heat pump performance line and intersects the heat loss line, and mark this point I.
- L. Point I gives the temperature where balance point #4 should be.

(NOTE: By following this procedure, additional balance points can be plotted as design conditions require.)

X. Procedure for sizing a heat pump on the cooling load

- A. Determine heat gain and calculate cooling load.

(NOTE: In design conditions where the COP average of the heat pump is 2.25 or higher, the unit can usually be sized on the cooling load and provide a compatible match with the heat load.)

- B. Select a system that has a Btuh cooling capacity equal to or slightly beyond the cooling load, but never select a system with a Btuh cooling capacity below the estimated cooling load.
- C. Use the nominal cfm rating of the unit as the air quantity for duct sizing.

Example: If the cooling load is 33,800 Btuh, select a 3-ton unit 12,000 Btuh per ton or 36,000 total Btuh; with a summer outdoor design temperature of 95°F and an entering wet bulb temperature of 67°F, 35,000 Btuh will easily handle the 33,800 Btuh cooling load requirement and provide the required 400 cfm/ton air quantity requirement for the 3-ton unit which would be a total of 1,200 cfm.

INFORMATION SHEET

Typical 3-ton split system

TEMP (F) AIR ENT OUTDOOR Unit	AIR ENT INDOOR UNIT-CFM								
	1200			1350			1500		
	INDOOR UNIT ENT AIR TEMP-E _{wb} (F)								
	72	67	62	72	67	62	72	67	62
85	36	33	30	41	37	34	43	39	35
95	34	(31)	29	38	35	32	39	36	33
100	33	30	29	37	34	31	38	35	32

- D. Plot heat pump performance curve on a graph.
- E. Determine structure heat loss and plot it on the graph in relation to design conditions.
- F. Establish balance point #1.
- G. Establish additional balance points as required.

Example: Assume an inside design temperature of 70°F minus a 5°F credit, an outside temperature of 15°F, and a structure heat loss of 40,000 Btuh; supplemental heating requirements can be determined by following the procedure outlined in Objective IX.

Plotting balance points indicates a need for 8-kw of supplementary heat; 4-kw would be energized in the first two heating stages by the indoor thermostat at BP #1, 2-kw would be energized by the first outdoor thermostat at BP #2, and the final 2-kw would be energized by the second outdoor thermostat at BP #3, and the unit is well balanced for both heating and cooling.

XI. Important advantages of controlled heating stages

- A. They meet most power company specifications that require large, instantaneous load increases to be minimized.
- B. They eliminate shorter fan cycles and stratification.
- C. They provide the occupant with a built-in warning system in the event of compressor failure.

(NOTE: In the event of a compressor failure, staged heating would allow inside temperature to drop to a noticeable level, but if all supplemental heat is energized, occupants would feel no discomfort and not realize there had been a compressor failure unless the system had a separate warning circuit.)

INFORMATION SHEET

XII. Installation considerations related to heat pump performance

- A. When prevailing winds are from the west or north, the outside unit should be placed on the south or east side of the structure.

(NOTE: This minimizes wind through the unit during the defrost cycle and helps reduce ice buildup on the slab beneath the coil.)

- B. When equipment is placed on a roof, a windshield should be placed so that it will help keep air from blowing directly on the outdoor coil.
- C. Both indoor and outdoor units should be located so there is ample room for service, and all sides of the outdoor unit should be accessible.
- D. Operating voltage should not be less than 10% of nameplate rating.
- E. Manufacturer's instructions should be carefully followed.
- F. Balance points should be established to most effectively supplement performance.

Typical Balance Points

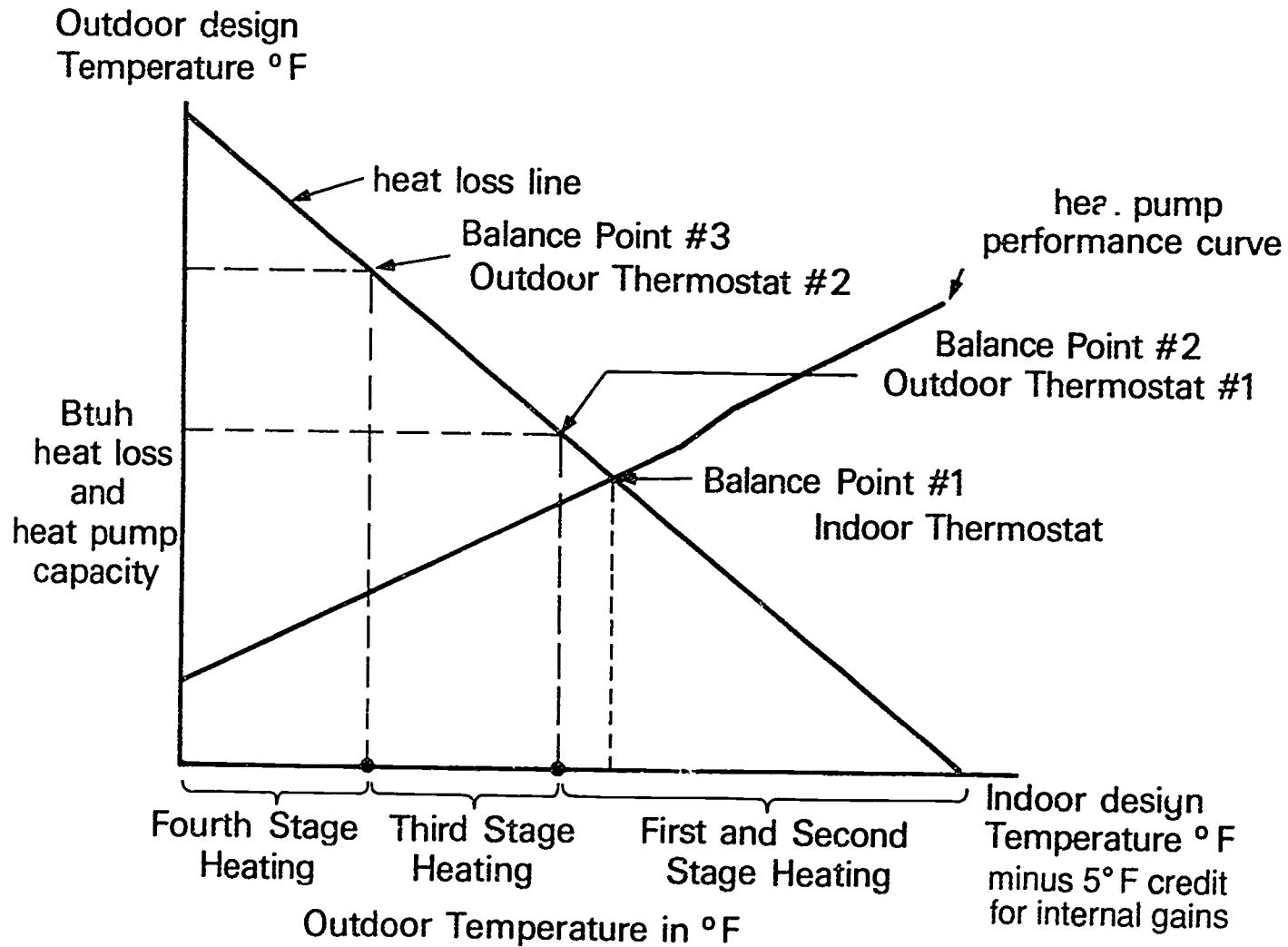

Plotting Balance Point #1

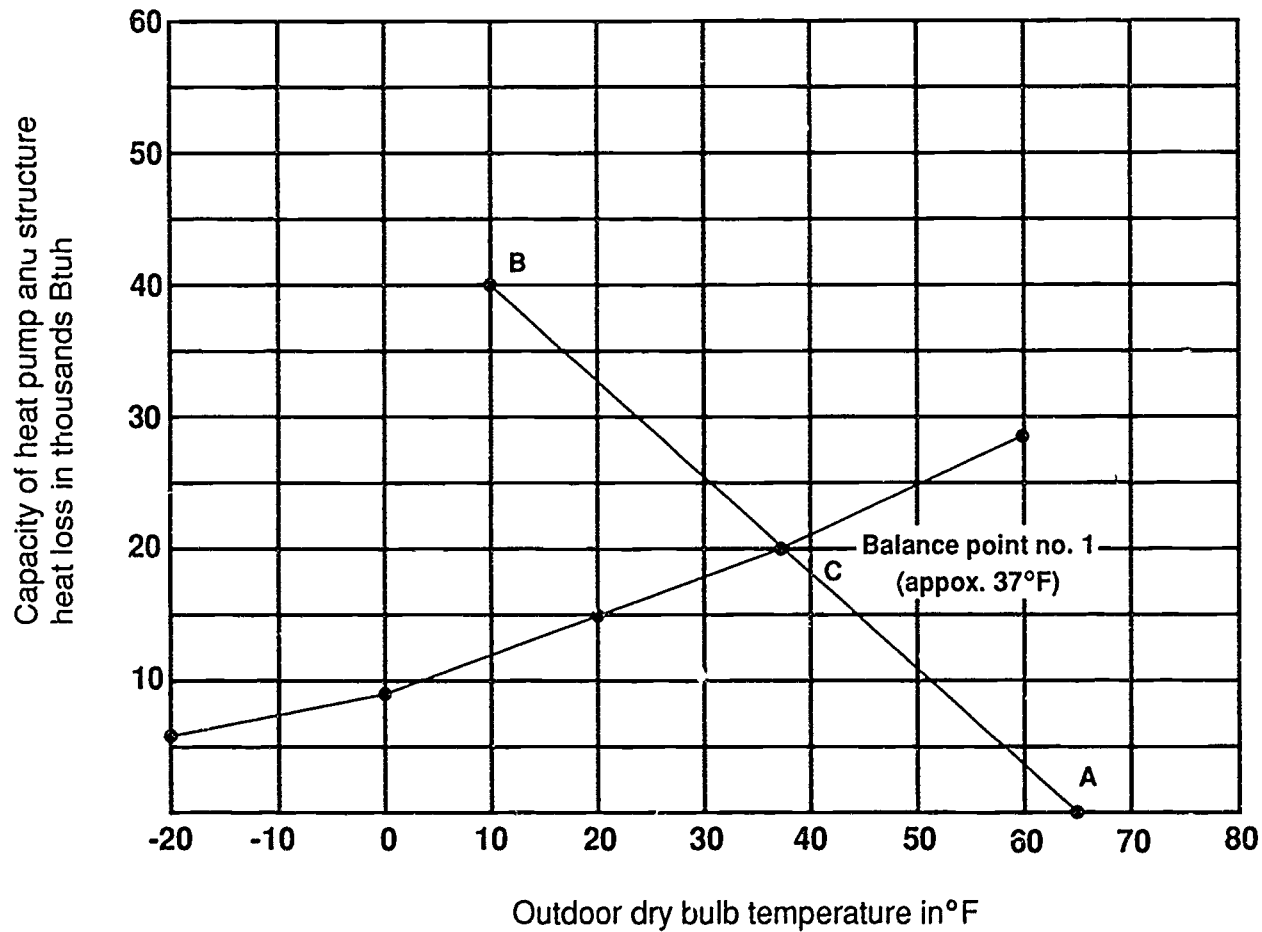

Plotting Additional Balance Points

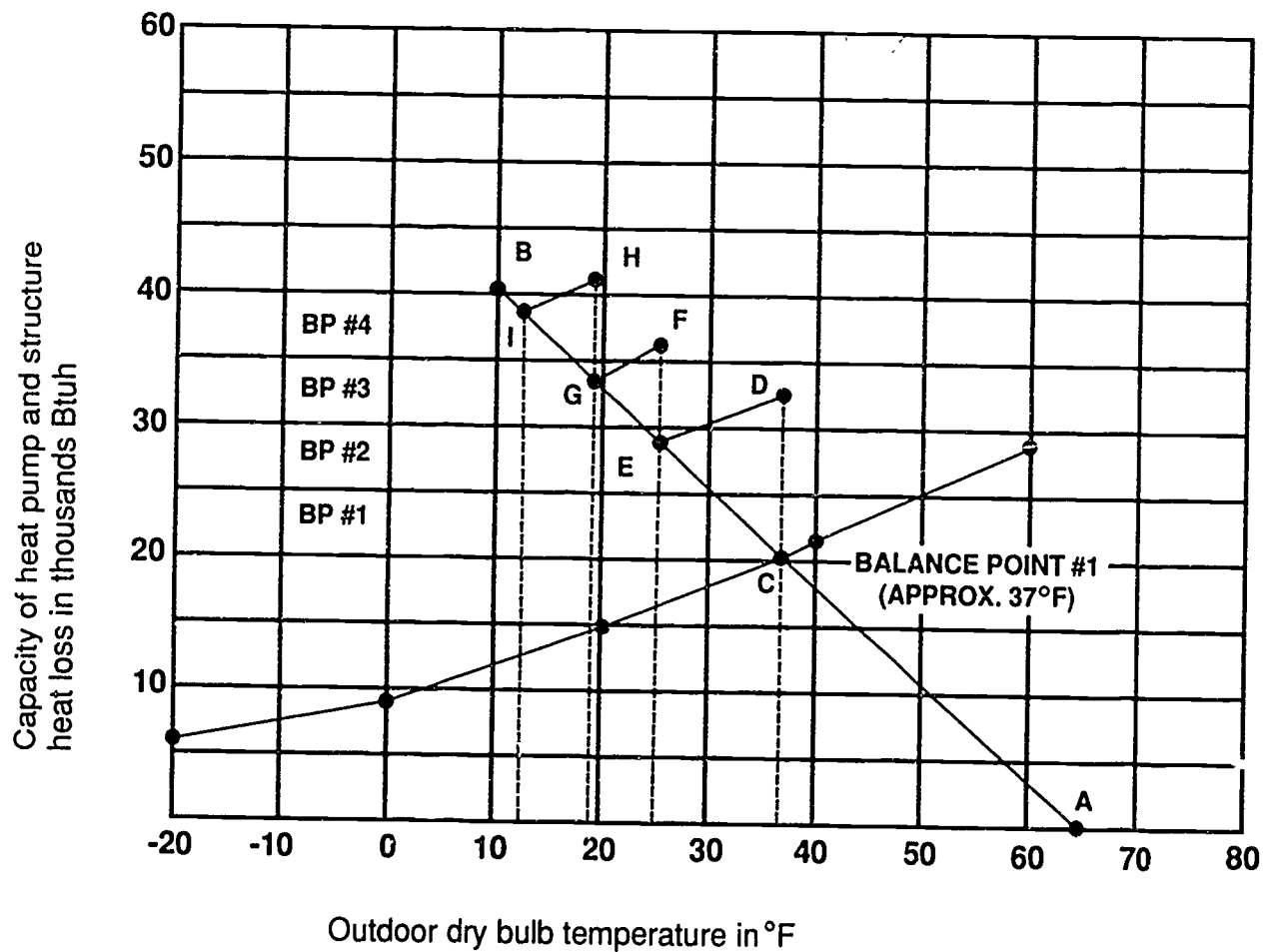

**BALANCE POINTS
UNIT XV**

ASSIGNMENT SHEET #1 — SIZE A HEAT PUMP ON THE COOLING LOAD

Directions: Assume that the cooling load for a residence has been calculated at 32,500 Btuh with a summer outdoor design temperature of 95°F and an entering wet bulb temperature of 62°F. Assume also that the air quantity requirements are 400 cfm/ton. Using the table in Figure 1, answer the following questions:

- A. What size unit should be selected? _____
- B. What is the Btuh rating of the unit? _____
- C. From what factor can the air quantity for duct sizing be determined?

FIGURE 1

TEMP (F) AIR ENT OUTDOOR Unit	AIR ENT INDOOR UNIT-CFM								
	1200			1350			1500		
	INDOOR UNIT ENT AIR TEMP-Ewb (F)								
	72	67	62	72	67	62	72	67	62
85	36	33	30	41	37	34	43	39	35
95	34	31	29	38	35	32	39	36	33
100	33	30	29	37	34	31	38	35	32

**BALANCE POINTS
UNIT XV**

**ASSIGNMENT SHEET #2 — PLOT BALANCE POINTS FOR A HEAT
PUMP AT GIVEN DESIGN CONDITIONS**

Directions: Using the graph below, plot a heat pump performance curve, heat loss line, and all balance points for the following design conditions: Structure heat loss, 35,000 Btuh; indoor design temperature, 65°F; outdoor design temperature, 15°F. Use the manufacturer's specifications in the example in item C, Objective VII to plot the heat pump performance curve. Assume the indoor thermostat energizes two 2-kw strip heaters and that all outdoor thermostats energize single 2-kw strip heaters. After balance points are plotted, answer the following questions:

- A. What is the approximate °F at balance point #1? _____
- B. What is the approximate °F at balance point #2? _____
- C. What is the approximate °F at balance point #3? _____
- D. Will there be a need for a balance point #4? _____

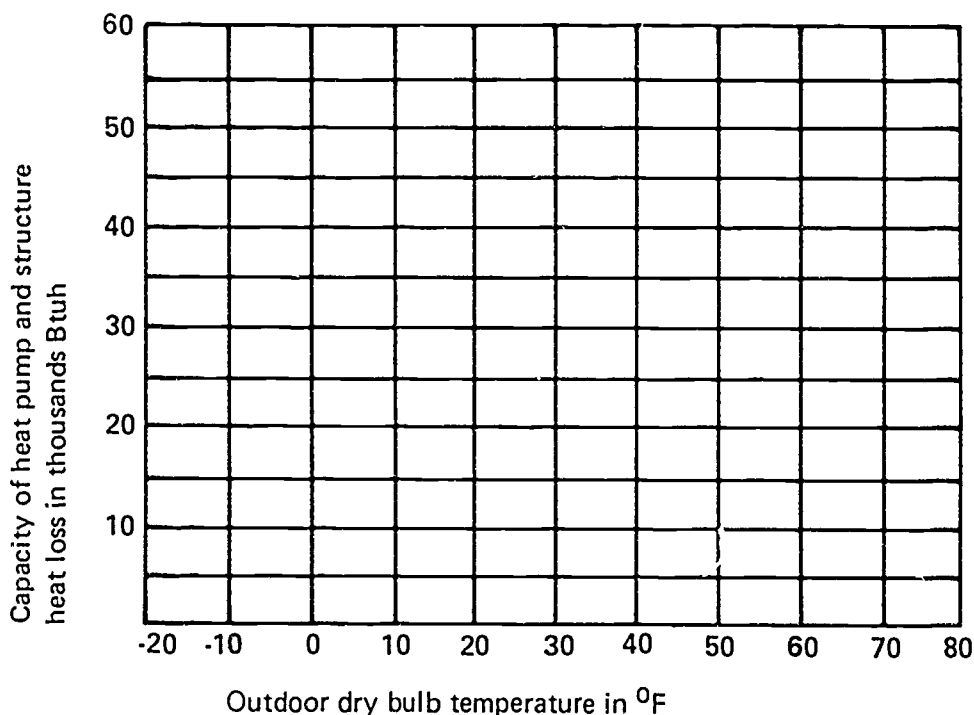

**BALANCE POINTS
UNIT XV****ASSIGNMENT SHEET #3 — LOCATE EQUIPMENT TO
OBTAIN MAXIMUM COP FROM A HEAT PUMP**

Directions: Assume the residence in the following plot plan is in an area where the prevailing winds are from the northwest. Answer the following questions:

- A. Of the points A, B, and C, which is the best place to locate the outdoor unit of the heat pump to obtain maximum COP from the unit?

- B. If the outdoor unit had to be installed on the roof, what should be done to help obtain maximum COP from the outdoor unit?

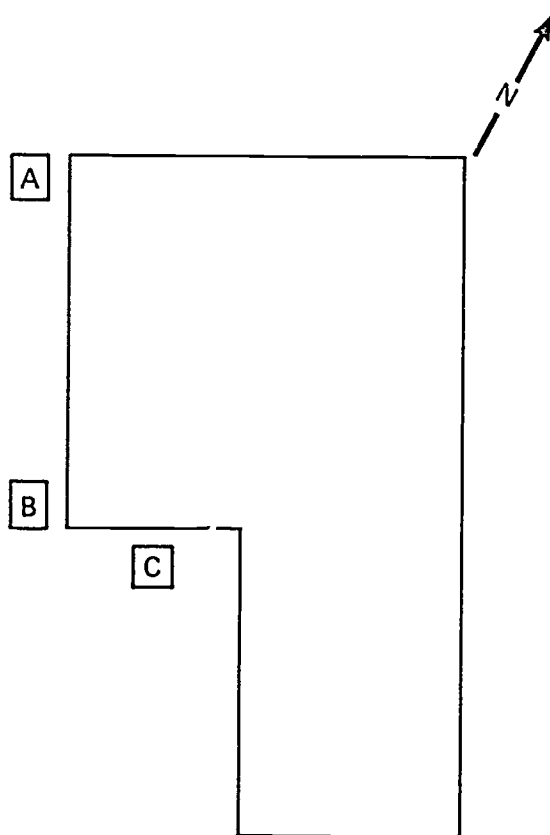

**BALANCE POINTS
UNIT XV****ANSWERS TO ASSIGNMENT SHEETS****Assignment Sheet #1**

- a. 3-ton
- b. 36,000 Btuh
- c. The cfm rating of the air quantity for the unit

Assignment Sheet #2

(Answers to a, b, and c should be within 2°F of those shown)

- a. 37°F
- b. 25°
- c. 17°
- d. No

Assignment Sheet #3

- a. C
- b. A windshield should be placed so that it will help keep air from blowing directly on the outdoor coil

**BALANCE POINTS
UNIT XV****JOB SHEET #1—SET OUTDOOR THERMOSTATS FOR
PROPER STAGING OF AUXILIARY HEAT**

- a. Tools and equipment
1. Technician's tool pouch/box
 2. Heat pump as selected by instructor
 3. Balance points as determined by local conditions
 4. Heat load of selected structure
 5. Performance chart of selected heat pump
 6. Pencil and paper
 7. Safety glasses
- B. Procedure
1. Work with your instructor to determine the balance points required for the selected system.
 2. Write and record the balance points by numbers and degrees.
 3. Locate the outdoor thermostat on the outdoor section of the selected heat pump.

(NOTE: It is referred to as the "outdoor" thermostat, but with some systems it may actually be in the attic of the structure or attached to the indoor section, or located in a remote place.)
 4. Put on safety glasses.
 5. Set the balance points according to the order in which they are energized.

(NOTE: Actually setting balance points requires judgement about local wind conditions that may accelerate heat loss from a structure. In such a situation, the balance points may need to be set just a little higher than the chart indicates. A period of operation may require further adjustments.)
 6. Allow for a period of operation under temperature conditions used in planning the balance points.
 7. Check with occupants of the structure to determine if supplementary heat is performing satisfactorily.
 8. Make adjustments as required.

JOB SHEET #1

Have your instructor check your work.

9. Return tools to proper storage.

818

**BALANCE POINTS
UNIT XV**

PRACTICAL TEST #1

**JOB SHEET #1—SET OUTDOOR THERMOSTATS FOR PROPER
STAGING OF AUXILIARY HEAT**

Student's name _____ Date _____

Evaluator's name _____ Attempt no. _____

Student instructions: When you are ready to perform this task, ask your instructor to observe the procedure and complete this form. All items listed under "Process Evaluation" must receive a "Yes" for you to receive an overall performance evaluation.

PROCESS EVALUATION

(EVALUATOR NOTE: Place a check mark in the "Yes" or "No" blanks to designate whether or not the student has satisfactorily achieved each step in this procedure. If the student is unable to achieve this competency, have the student review the materials and try again.)

The student:	YES	NO
1. Established balance points by numbers and degrees.	<input type="checkbox"/>	<input type="checkbox"/>
2. Located outdoor thermostat, or proper thermostat.	<input type="checkbox"/>	<input type="checkbox"/>
3. Set balance points in the order in which they are energized.	<input type="checkbox"/>	<input type="checkbox"/>
4. Allowed for performance period to verify operation.	<input type="checkbox"/>	<input type="checkbox"/>
5. Verified operation with occupants of structure.	<input type="checkbox"/>	<input type="checkbox"/>
6. Made required adjustments.	<input type="checkbox"/>	<input type="checkbox"/>

Evaluator's comments: _____

JOB SHEET #1 PRACTICAL TEST

PRODUCT EVALUATION

(EVALUATOR NOTE: Rate the student on the following criteria by circling the appropriate numbers. Each item must be rated at least a "3" for mastery to be demonstrated. (See performance evaluation key below.) If the student is unable to demonstrate mastery, student materials should be reviewed and another test procedure must be submitted for evaluation.)

Criteria:

Balance point selection	4	3	2	1
Balance point settings	4	3	2	1
Verification procedure	4	3	2	1
Required adjustments	4	3	2	1

EVALUATOR'S COMMENTS: _____

PERFORMANCE EVALUATION KEY

- 4 — **Skilled** — Can perform job with no additional training.
- 3 — **Moderately skilled** — Has performed job during training program; limited additional training may be required.
- 2 — **Limited skill** — Has performed job during training program; additional training is required to develop skill.
- 1 — **Unskilled** — Is familiar with process, but is unable to perform job.

(EVALUATOR NOTE: If an average score is needed to coincide with a competency profile, total the designated points in "Product Evaluation" and divide by the total number of criteria.)

820

**BALANCE POINTS
UNIT XV**

TEST

Name _____ Score _____

1. Match the terms on the right with their correct definitions.

- | | |
|---|--|
| <p>_____ a. The point, expressed in °F, where the heat pump capacity is equal to or balanced with the heat loss of the structure</p> <p>_____ b. Points beyond the initial balance point which indicate the most advantageous temperatures for energizing supplementary heating</p> <p>_____ c. A system of identifying the initial balance point as balance point #1, and additional balance points as balance point #2, balance point #3, etc.</p> <p>_____ d. Electrical heating strips programmed to energize in stages to compensate for reduced heat pump capacity as temperature drops</p> <p>_____ e. The point at which a heat pump/fossil fuel system is automatically switched from one energy source to an alternate energy source</p> <p>_____ f. Coefficient of performance, the ratio of heat output to heat input</p> <p>_____ g. The total estimated heat output in BTU's for the entire heating season divided by the estimated total energy consumed</p> | <p>1. Balance point number</p> <p>2. COP</p> <p>3. Economic balance point</p> <p>4. Balance point</p> <p>5. Supplementary heating</p> <p>6. Additional balance points</p> <p>7. HSPF</p> |
|---|--|

2. Distinguish between the COP of a direct electrical heating element and the COP of a heat pump. Place an "X" beside the blank that indicates the COP of a heat pump.

- _____ a. These heating devices have a COP of 1.0.
- _____ b. These heating devices have a COP that is always greater than 1.0.

TEST

3. Determine the COP of a heat pump that has a 4,400 watt input and a 40,000 Btuh output. Use the formula $COP = \frac{\text{Btuh output}}{\text{Btuh input}}$

Answer _____

4. Select true statements concerning balance points and their relation to COP. Place an "X" beside each true statement.

- ____ a. When the COP of a heat pump drops, balance points maintain economical heating continuity in a conditioned space.
- ____ b. Balance points promote maximum COP.
- ____ c. Balance points do not assist in determining equipment size and the amount of supplemental heat required.
- ____ d. The economic balance point of a heat pump/fossil fuel system can be determined only after utility rates are known.

5. Match balance points with typical stages in heating continuity.

- | | | |
|---------|--|---------------------|
| ____ a. | When outdoor temperature falls below this point, an indoor thermostat calls for second-stage heat and the first two heating elements will energize. | 1. Balance point #2 |
| | | 2. Balance point #3 |
| | | 3. Balance point #1 |
| ____ b. | When outdoor temperature continues to fall, an outdoor thermostat calls for third-stage heat and a third heating elements is energized. | |
| ____ c. | When outdoor temperature continues to fall even more, a second outdoor thermostat calls for fourth-stage heat and a fourth heating element is energized. | |

6. Complete a list of factors needed to plot balance points.

- a. _____
- b. Heat loss calculation of the structure
- c. _____
- d. Inside design temperature

TEST

7. Plot a heat pump performance curve on the graph below using the following manufacturer's specifications for an air to air heat pump.

Outdoor Temperature (Degree F)	Total Output (Btuh)
65	44,600
60	42,000
55	39,100
50	36,500
45	33,900
40	31,600
35	29,100
30	26,700
25	24,100
20	21,500
15	19,500
10	16,900
5	14,900
0	12,300
-5	10,300
-10	8800
-15	7500
-20	6200

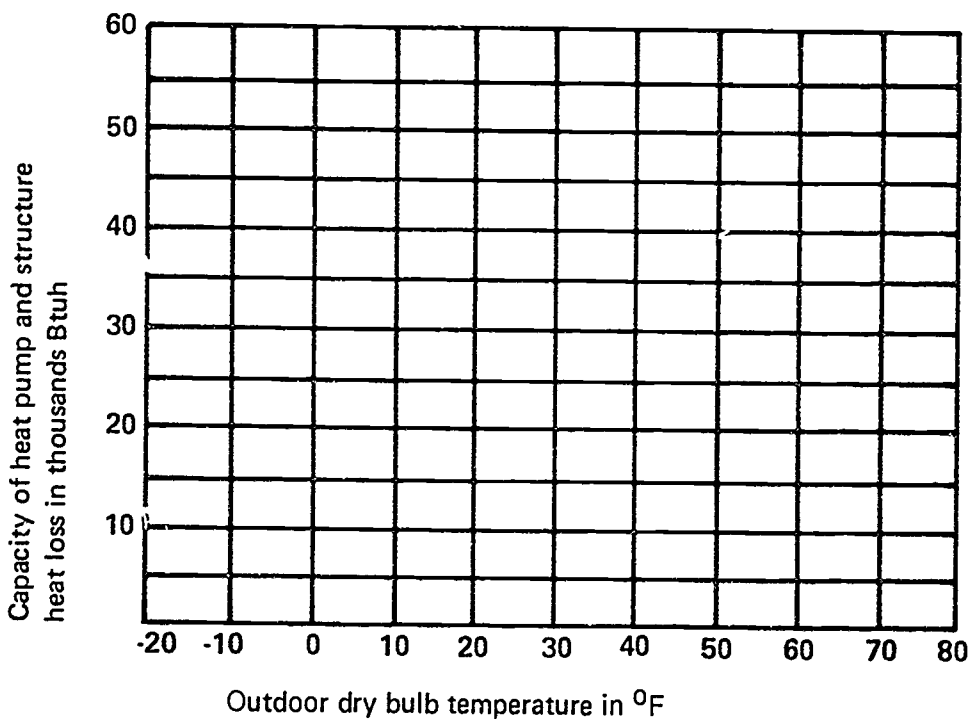

TEST

8. Plot balance point #1 using the heat pump performance curve shown below and an indoor design temperature of 70°F minus a 5°F credit; outside design temperature of 10°F; and a structure heat loss of 45,000 Btuh.

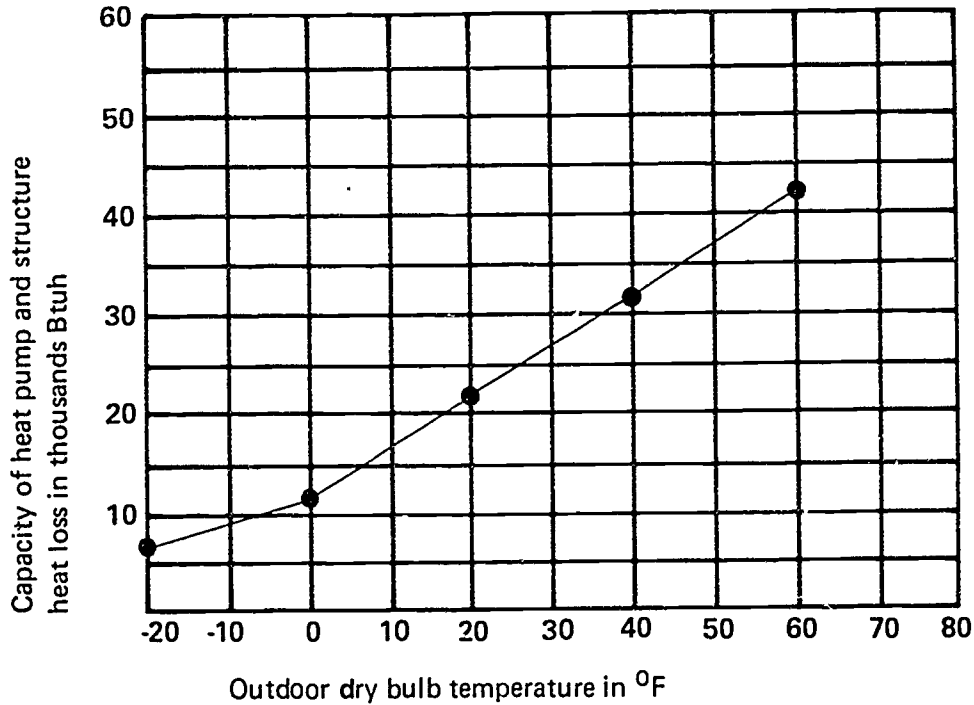

9. Plot additional balance points for the design conditions given in question 8, assuming that the indoor thermostat at balance point #1 energizes 4-kw of supplemental heating and all outside thermostats energize 2-kw strip heaters.

(NOTE: Use the graph in question 8 to complete this test item, use broken lines to indicate your plotting, and circle and label all balance points.)

TEST

10. Select true statements concerning the procedure for sizing a heat pump on the cooling load. Place an "X" beside each true statement.
- a. Determine heat gain and calculate cooling load.
 - b. Select a system that has a Btuh cooling capacity equal to or slightly below the cooling load, but never select a system with a Btuh cooling capacity above the estimated cooling load.
 - c. Use the nominal cfm rating of the unit as the air quantity for duct sizing.
 - d. Plot heat pump performance curve on a graph.
 - e. Determine structure heat loss and plot it on the graph in relation to design conditions.
 - f. Establish balance point #1.
 - g. Establish additional balance points as required.

11. List two advantages of controlled heating stages.

- a. _____

- b. _____

12. Select true statements concerning installation considerations related to heat pump performance. Place an "X" beside each true statement.
- a. When prevailing winds are from the west or north, the outside unit should be placed on the south or east side of the structure.
 - b. When equipment is placed on a roof, a windshield should be placed so that it will help keep air from blowing directly on the outdoor coil.
 - c. Both indoor and outdoor units should be located so there is ample room for service, and all sides of the outdoor unit should be accessible.
 - d. Operating voltage should not be less than 10% of nameplate rating.

(NOTE: If the following activities have not been accomplished prior to the test, ask your instructor when they should be completed.)

13. Size a heat pump on the cooling load. (Assignment Sheet #1)
14. Plot balance points for a heat pump at given design conditions. (Assignment Sheet #2)

TEST

15. Locate equipment to obtain maximum COP from a heat pump. (Assignment Sheet #3)
16. Demonstrate the ability to set outdoor thermostats for proper staging of auxiliary heat. (Job Sheet #1)

826

BALANCE POINTS
UNIT XV

ANSWERS TO TEST

1. a. 4 d. 5 g. 7
 b. 6 e. 3
 c. 1 f. 2

2. b

3. 3.1

4. a, b, d

5. a. 3
 b. 1
 c. 2

6. a. Performance curve based on Btuh of the heat pump
 b. Outside design temperature

7.

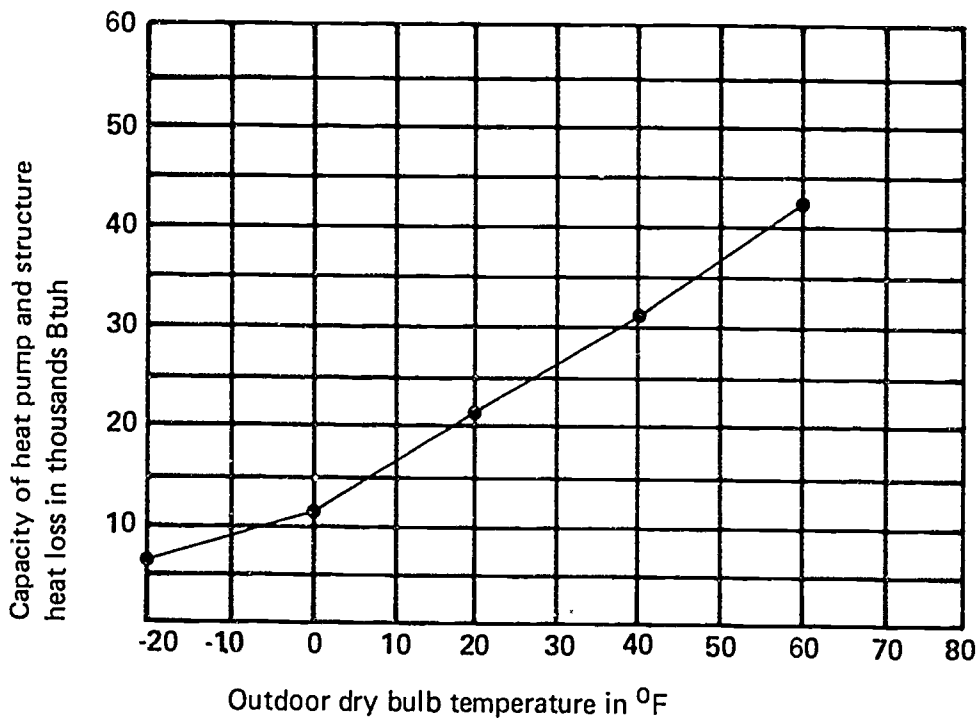

ANSWERS TO TEST

8.

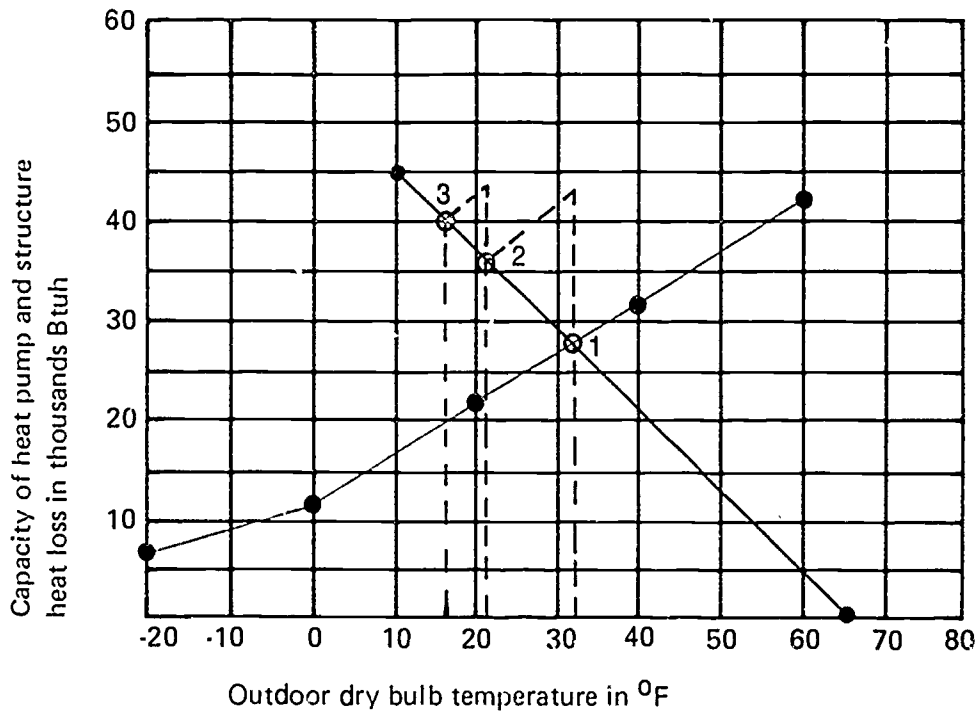

9. Answers are incorporated in the graph in answer 8
10. a, c, d, e, f, g
11. Any two of the following:
- They meet most power company specifications that require large, instantaneous load increases to be minimized.
 - They eliminate shorter fan cycles and stratification.
 - They provide the occupant with a built-in warning system in the event of compressor failure.
12. a, b, c, d
13. Evaluated according to answers to assignment sheets

ANSWERS TO TEST

14. Evaluated according to answers to assignment sheets
15. Evaluated according to answers to assignment sheets
16. Evaluated according to criteria in Practical Test #1



INTRODUCTION TO HYDRONICS UNIT XVI

UNIT OBJECTIVE

After completion of this unit, the student should be able to design a series loop, single circuit hydronic system for a residence. This competency will be demonstrated by completing the assignment sheets, and by scoring a minimum of 85 percent on the unit test.

SPECIFIC OBJECTIVES

After completion of this unit, the student should be able to:

1. Match terms related to hydronics with their correct definitions.
2. Distinguish between basic types of hydronic systems.
3. Match classifications of hydronic systems with their water temperature/pressure characteristics.
4. Identify types of common hydronic system designs.
5. Match common hydronic system designs with their advantages and disadvantages.
6. Select true statements about design water temperature.
7. Match terminal units with their design water temperature drop.
8. Solve a problem involving design water flow rates through circuits.
9. Match minimum flow rates through terminal units with their tubing sizes.
10. Select true statements concerning placement of terminal units.
11. Match terminal units with their characteristics and uses.
12. Complete a list of steps in the selection and sizing of terminal units.
13. Select true statements concerning fuels, ratings, and selection of boilers.

SPECIFIC OBJECTIVES

14. Distinguish between advantages and disadvantages of types of residential expansion tanks.
15. Select true statements concerning steps in the selection of residential expansion tanks.
16. Select true statements concerning the types, designs, and sizing of residential pumps.
17. Complete a list of factors in the selection of residential pumps.
18. Arrange in order the steps in selection of residential pumps.
19. Complete a list of factors affecting pipe sizing.
20. Select true statements concerning the procedure for selection of pipe sizes.
21. Match types of hydronic specialties with their characteristics and uses.
22. Select true statements concerning steps in designing a hydronic system.
23. Select true statements concerning integrated water heater/space heating.
24. Solve problems concerning pulse combustion boilers.
25. Solve problems concerning wall-mounted boilers.
26. Lay out a series loop single circuit hydronic system with boiler located under floor of dining room. (Assignment Sheet #1)
27. Select boiler and expansion tanks. (Assignment Sheet #2)
28. Make a trial selection of pump and select pipe size for series loop system. (Assignment Sheet #3)

INTRODUCTION TO HYDRONICS UNIT XVI

SUGGESTED ACTIVITIES

- A. Obtain additional materials and/or invite resource people to class to supplement/reinforce information provided in this unit of instruction.

(NOTE: This activity should be completed prior to the teaching of this unit.)

- B. Make transparencies from the transparency masters included with this unit.
- C. Provide students with objective sheet.
- D. Discuss unit and specific objectives.
- E. Provide students with information and assignment sheets.
- F. Discuss information and assignment sheets.

(NOTE: Use the transparencies as needed to enhance the information.)

- G. Integrate the following activities throughout the teaching of this unit:
1. Arrange a field trip to see a hydronic system installation if possible.
 2. Invite manufacturers representative to discuss newer, more efficient equipment now available in the market.
 3. Meet individually with students to evaluate their progress through this unit of instruction, and indicate to them possible areas for improvement.
- H. Give test.
- I. Evaluate test.
- K. Reteach if necessary.

REFERENCES USED IN DEVELOPING THIS UNIT

- A. Harris, W. S. *Modern Hydronic Heating*. NHAW Home Study Institute.
- B. *Pump and System Curve Data for Centrifugal Pump Selection and Application*, Bulletin No. TEH 375. Bell & Gossett Division, ITT.
- C. *Parallel and Series Pump Application*, Bulletin No. TEH 1065. Bell & Gossett Division, ITT.
- D. *One Primary Systems Flow Rate and Water Temperature Determination*, Bulletin No. TEH 1066. Bell & Gossett Division, ITT.

SUGGESTED ACTIVITIES

- E. *Basic System Control and Valve Sizing Procedures, Bulletin No. 1165.* Bell & Gossett Division, ITT.
- F. *Fundamentals ASHRAE Handbook and Product Directory, 1977*
- G. Eckes, William, and Dan Fulkerson. *Air Conditioning and Refrigeration, Book Four.* Stillwater, OK 74074: Mid-America Vocational Curriculum Consortium, Inc., 1981.
- H. *The AquaTherm System.* Dallas, TX 75227: FIRST CO., 1987.

833

**INTRODUCTION TO HYDRONICS
UNIT XVI**

INFORMATION SHEET

I. Terms and definitions

- A. **Hot water or steam coils** — Transfer heat from the water to the air which is blown through the coil; similar in construction to automobile radiators and located in air ducts
- B. **Head** — The pressure exerted by a column of water measured in the height of the water column
- C. **Forced circulation system** — System which requires pump pressure for circulation
- D. **Tankless water heater** — A device immersed in a boiler which transfers heat from the boiler to the domestic hot water supply of a structure
- E. **Psi** — Pounds per square inch of pressure
- F. **Chilled water** — Water which has been cooled before circulating through coils for cooling purposes
- G. **Radiant heat** — The heat delivered from a hot or warm surface to a cooler surface by radiation of infrared rays
- H. **MBH** — Heat expressed in thousands of Btu's per hour
- I. **Btuh** — British thermal units per hour
- J. **Gpm** — Flow rate in gallons per minute
- K. **IBR** — Institute of Boiler and Radiator Manufacturers
- L. **Centrifugal pump** — A type of pump where fluid is "thrown" by an impeller rather than "pushed" by a piston
- M. **Hydronics** — The science of heating with water
- N. **Design water temperature drop** — The difference in temperature between supply and return water temperature at the boiler at design output
- O. **Terminal units** — Equipment which releases heat from a hydronic system to a conditioned space

INFORMATION SHEET

- P. **Pulse combustion boilers** — Boilers whose initial cycle is ignited by a spark, but ensuing mix/burn cycles are ignited by heat from the previous cycle
- Q. **Wall-mounted boilers** — Units designed to provide hydronic heating in apartments and condominiums where individual utility metering is required
- R. **Integrated systems** — Heating systems that combine a hot water supply from a standard water heater with a heating coil in an air handler to provide economical heat through existing ductwork

II. Basic types of hydronic systems

A. Hydronic gravity system

(NOTE: Hydronic gravity systems are seldom used in the United States.)

1. Operates on the principle that hot water is lighter than cold water

(NOTE: The difference between the weight of hot water and the weight of cold water is expressed in millinches (.001 in.) per foot of height.)

2. Head seldom exceeds 3 to 4 inches in gravity system
3. Requires much larger pipe systems

(NOTE: The gravity system often requires up to 2½" pipe.)

B. Forced circulation system

(NOTE: Because of their advantages, forced circulation systems have replaced gravity systems in the United States.)

1. Operates on pump pressure rather than gravity
2. Head may be 8-15 feet
3. Frequently uses pipe size ¾" to 1½"
4. When tankless water heater is present, provision must be made to prevent gravity effect during off cycle

III. Classifications of hydronic systems by water temperature/pressure characteristics

A. Low temperature water system (LTW)

1. Maximum temperature—250 degrees
2. Maximum pressure—160 psi
3. Usual upper limit—30 psi

INFORMATION SHEET

- B. Medium temperature water system (MTW)
 - 1. Maximum temperature—350 degrees
 - 2. Maximum pressure—150 psi
 - 3. Usual design temperature—250 to 325 degrees
 - 4. Usual design pressure—150 psi
- C. High temperature water system (HTW)
 - 1. Minimum temperature—Over 350 degrees
 - 2. Maximum temperature— 400 to 450 degrees
 - 3. Usual pressure—300 psi
- D. Chilled water (CW)
 - 1. Usual temperature—40 to 50 degrees
 - 2. Operating pressure— 125 psi

(NOTE: For process applications below 40 degrees, water is replaced with anti-freeze solution or brine. Well water may be used in chilled water application at temperatures below 60 degrees.)

- E. Dual-temperature system (DTW)
 - 1. Hot and chilled water
 - 2. Usual temperatures of 100 to 150 degrees, winter
 - 3. Usual temperatures of 40 to 55 degrees, summer

IV. Common hydronic system designs

- A. Series loop — The series loop hydronic system makes one continuous loop around the perimeter of the structure. It is most common in small residences and small buildings. (Transparency 1)
- B. One pipe system — Individual terminal units are connected to one pipe loop by smaller pipes and hydronic fittings. (Transparency 1)
- C. Two pipe reverse return system — The two pipe reverse return system has a common supply loop to all terminal units in the circuit. It has a separate circuit of return water from the terminal units in reverse order from the supply. (Transparency 2)

INFORMATION SHEET

- D. Two pipe direct return system — In the two pipe direct return system the supply pipe ends at the farthest terminal unit and the return pipe starts at the farthest terminal unit. (Transparency 3)
- E. Panel system — Panel systems are built into the floor or the ceiling and use radiant heat. (Transparency 3)
- F. Multiple circuit systems — Multiple circuit systems can be used on any other type of system. (Transparency 4)

V. Common hydronic system designs and their advantages and disadvantages

- A. Series loop
 - 1. Advantage — Low installation cost
 - 2. Disadvantages
 - a. Water temperature is progressively reduced around circuit requiring allowance for colder water for heating purposes.
 - b. Water temperature and rate of flow to any terminal unit within a circuit cannot be regulated without affecting all other terminal units in the circuit.
 - c. Tube size in terminal unit limits flow of water and capacity of system.
- B. One pipe system
 - 1. Advantage — Possible to control flow and heat from individual terminal units
 - 2. Disadvantages
 - a. Higher in cost than the series loop system
 - b. Shows progressive drop in temperature around the water circuit
- C. Two pipe reverse return system
 - 1. Advantages
 - a. Equalizes distance water flows through each terminal unit and equalizes temperature drop
 - b. Eliminates allowance for temperature drop between terminal units
 - c. Individual control of terminal units does not affect other terminal units
 - 2. Disadvantage — Additional pipe increases cost

INFORMATION SHEET

- D. Two pipe direct return system
 - 1. Advantages
 - a. Valuable in dual temperature split system
 - b. Lower in cost than reverse return system
 - 2. Disadvantages
 - a. Creates balancing problems due to different temperature drops across terminal units with low resistance to flow
 - b. Limited applications unless the terminal units have high resistance to flow
- E. Panel system
 - 1. Advantage — Does not interfere with placement of furniture
 - 2. Disadvantage — Leaks are expensive to repair
- F. Multiple circuit system
 - 1. Advantages
 - a. Reduces the total length of circuits
 - b. Reduces number of terminal units in a circuit
 - c. Reduces pipe size of main trunk pipe
 - d. Simplifies pipe design in certain types of buildings
 - 2. Disadvantage — Could unnecessarily complicate an installation where a simple circuit would be satisfactory

VI. Design water temperature

- A. Design water temperature is not used when compensating for temperature drop through series loop circuits.
- B. High temperature requires less radiation equipment.
- C. It determines basis for selection of terminal units.
- D. It does not have any effect on selection of boiler size.
- E. Each circuit of a multiple circuit system may have a different design water temperature.

INFORMATION SHEET

VII. Terminal units and their design water temperature drop

- A. Cast iron radiator—30°
- B. Convectors—10°—30°
- C. Unit heaters—Up to 50°
- D. Baseboard—Up to 50°

(NOTE: Temperature drop does not affect selection of boiler size.)

VIII. Steps in determining design water flow rates through circuits

- A. Add heat loss of each area on circuit.
- B. Divide by 500.
- C. Divide again by design temperature drop.

(NOTE: 1 gpm equals 500 Btuh for each degree of temperature drop.)

Example: At 20 degree temperature drop

Area #1	23000 Btuh
Area #2	32000 Btuh
Area #3	<u>25000 Btuh</u>
TOTAL CIRCUIT "A"	80000 Btuh

$$80000/500 = 160$$

$$160/20 = 8 \text{ gpm, Circuit "A"}$$

IX. Tubing sizes of minimum flow rates through terminal units

(NOTE: Flow rates are determined by the manufacturer of the terminal unit. See the manufacturer's catalog for specific data.)

- A. 1/2" tube size—0.3 minimum design gpm
- B. 3/4" tube size—0.5 minimum design gpm
- C. 1" tube size—0.9 minimum design gpm
- D. 1 1/4" tube size—1.6 minimum design gpm

X. Placement of terminal units

- A. Terminal units should be placed under glass areas to counteract falling cold air from contact with cold glass.
- B. Terminal units may be placed along outside walls not containing glass.

INFORMATION SHEET

- C. When outside walls are used to fullest extent, balance of required terminal unit length may be placed along inside walls.
- D. Long, thin units along walls under windows produce more comfort economically than high, thin units.
- E. A unit on the stair landing will temper or stop the flow of cool air falling down stairs.
- F. Terminal units should distribute heat over the full length of long rooms to prevent spot heat.
- G. Forced air heaters should be installed so that heaters and registers do not create objectionable blasts of hot air.
- H. Combination heating and cooling units require special installation; follow manufacturers' recommendations.

XI. Terminal units and their characteristics and uses**A. Cast iron radiators (Transparency 5)**

(NOTE: Cast iron radiators are widely used in low water temperature systems.)

1. Column and large tube radiators are no longer manufactured but ratings are based on their performance.
2. Slim tube and wall type radiators are suitable for homes and small office buildings.
3. They may be hung on walls or ceilings where floor space is not available.
4. Modern radiators are rated in Btuh per square foot of Equivalent Direct Radiation (EDR). (Transparency 6)

B. Convectors

(NOTE: Used extensively in kitchen and baths where wall space is limited.)

1. Room air enters at bottom and passes between hot fins to reenter room through outlet at top of convector.
2. They deliver more heat for their size than radiators due to chimney effect of the cabinet.

INFORMATION SHEET**C. Baseboards (Transparency 7)**

(NOTE: Baseboards replace portions of conventional wood baseboard moldings.)

1. Made from hollow cast iron sections
2. Made from 3/4" to 1/2" copper tubing with aluminum fins surrounded by sheet metal enclosure with openings at top and bottom

D. Finned tube — Larger diameter, higher capacity commercial equivalents of residential baseboard terminals**E. Air heating coils**

1. Used to temper, reheat or boost heating of ducted air
2. Finned tube construction similar to air conditioning coils or automobile radiators
3. Must be protected from freezing
4. Ratings are not uniform due to varying air velocities, varying water velocities, varying air and water temperatures; use manufacturers' literature for ratings and coil selection

XII. Steps in the selection and sizing of terminal units

- A. Determine room heat loss and MBH.
- B. Determine design water temperature.
- C. Determine design temperature drop.
- D. Select adequate size terminal from manufacturers' literature.

XIII. Fuels, ratings, and selection of boilers**A. Fuels used for boilers**

1. Gas
2. Electricity
3. Coal
4. Oil

(NOTE: Boilers may be substituted by solar collectors. Solar heating will not be discussed in this unit.)

INFORMATION SHEET

- B. Ratings are in gross IBR output or net IBR output.
 - 1. Gross IBR output is not used for selecting boilers for residential application.
 - 2. Net IBR output is rated in Btuh for water boilers and in square feet of radiator area for steam boilers.
- C. In new construction, select boiler with net rating of 100% of connected load.
- D. When replacing boilers, recalculate the heat loss of the structure and select boiler in accordance with new calculations.
 - 1. Many older boilers are grossly oversized.
 - 2. Many new boilers are more efficient and installed capacity may be reduced.

XIV. Advantages and disadvantages of types of residential expansion tanks
(Transparencies 8 and 9)

- A. Open expansion tank
 - 1. Advantages
 - a. Permits the expansion of water when heated
 - b. Lower initial installation cost
 - 2. Disadvantages
 - a. Allows the evaporation of boiler water which must be replaced
 - b. Produces boiler scale and loss of efficiency due to the addition of make-up water
- B. Air cushion expansion tank
 - 1. Advantages — Maintains system pressure below safety pressure relief valve setting

(NOTE: The setting of the safety pressure relief valve is commonly 30 psi.)

INFORMATION SHEET

2. Disadvantages

- a. If sized too small, it will exceed the setting of the pressure relief
- b. If sized too large, it can result in noisy operation due to boiling in areas of less pressure
- c. Water can absorb the air and waterlog the expansion tank over a period of time

C. Air-cushion expansion tank with diaphragm (Transparency 10)

1. Advantages

- a. Permits smaller tank size due to prepressurization above the diaphragm
- b. Water cannot absorb the air that is trapped above the diaphragm

2. Disadvantage — More costly tank over a period of time

XV. Steps in the selection of residential expansion tanks

(NOTE: The selection of expansion tanks is subject to many variables such as height of water column, temperature of fill water, expansion of water, expansion of pipes, boiling temperature of water under pressure, etc. In large structures the calculation of expansion tank sizes and location of the tanks require an elaborate procedure which is beyond the scope of this unit of instruction.)

- A. Allow 1 gallon of tank capacity for each 5000 Btuh of total heat loss if conventional tank is used.
- B. Allow 1 gallon of tank capacity for each 7000 Btuh of total heat loss if prepressurized diaphragm tank is used, and prepressurized to at least 6 psig.
- C. If calculated tank size is not available, select next size larger tank.

XVI. Types, designs, and sizing of residential pumps

- A. Residential pumps are usually centrifugal.
- B. For a given motor horsepower, a pump can be designed to deliver either high volume at low pump head or high pump head at low volume.
- C. Residential pumps are sized from 5 to 150 gallons per minute with head pressures of 4 to 14 feet of head.

XVII. Factors in the selection of residential pumps

- A. For a given size of piping, pressure drop will increase as rate of flow increases.
- B. For a given rate of flow, pressure drop will decrease as size of pipe increases.

INFORMATION SHEET

- C. There will always be more than one combination of pipe size and pump head which will produce required water flow rate.

XVIII. Steps in the selection of residential pumps

- A. Determine design rate of flow in gpm.
- B. Refer to manufacturer's literature for pump performance curves.
- C. Make trial selection of several pumps with various available pump heads at design rate of flow.
- D. Make selections including consideration of cost of pumps.
- E. Solve for piping size and select proper pump for most economical total cost of piping and pump.

XIX. Factors affecting pipe sizing (Transparency 11)

- A. Rate of flow in gallons per minute
- B. Length of pipe circuit in feet of pipe
- C. Available pump head pressure
- D. Cost of pipe and fittings

XX. Procedure for selection of pipe sizes

- A. Refer to pipe sizing table in manufacturer's literature.
- B. Refer to pump manufacturer's pump performance charts.
- C. Plot pipe size curves on pump performance curves for various acceptable sizes of pipe.
- D. Select most economical combination of pipe size and pump size.
- E. If total system cost is not acceptable, select new system design.
 - 1. Increase or decrease number of circuits.
 - 2. Increase or decrease number of pumps.
 - 3. Increase or decrease sophistication of specialty fittings and controls.
 - 4. Increase or decrease design water temperature.
 - 5. Increase or decrease design temperature drop.

INFORMATION SHEET

XXI. Types of hydronic specialties and their characteristics and uses

- A. Air eliminating devices
 - 1. Eliminates air absorbed by water
 - 2. Usually located at the boiler
- B. Air vents
 - 1. Eliminates air trapped in system
 - 2. Usually installed in high points in system at terminal units
 - 3. May be either manually operated or automatic
- C. Fill valve
 - 1. Common globe valve in old manually operated systems
 - 2. In modern automatic systems, the fill valve is a combination pressure reducing valve set at 12 psi combined with a check valve
 - a. Adds water to boiler when pressure drops below set point of fill valve
 - b. Prevents boiler water from backing into municipal water system
- D. Balancing valves
 - 1. Used in multiple circuit systems
 - 2. Regulates flow rate of water in separate circuits
 - 3. Usually inexpensive square head cock valves
 - 4. Usually located in return legs of branch circuits at manifold near boiler
- E. Flow control valve
 - 1. Used to prevent gravity effect of rising hot water during off cycle
 - 2. Usually a type of weighted check valve with enough resistance to prevent hot water from rising by gravity but will open easily under pump pressure
- F. Pressure relief valve
 - 1. Used as a safety valve
 - 2. Usually comes as part of boiler

INFORMATION SHEET

3. Must be capable of discharging full Btuh rating of boiler in form of steam at a pressure setting 3 psig above rated working pressure of boiler
 4. Discharge rate is indicated on nameplate of valve
- G. One-pipe fitting
1. Used in one pipe systems
 2. Operates as a choke on supply loop to divert water to terminal unit
- H. Zone valve
1. Used to open or shut off flow of hot water to a zone
 2. Thermostatically controlled
 3. Either motorized or solenoid operated

XXII. Steps in designing a hydronic system

- A. Calculate heat loss.
- B. Make trial selection of system design.
- D. Make a layout of piping system.
- C. Calculate heat loss.
- D. Determine Btuh requirements for each circuit or zone of piping system.
- E. Select design system temperature and design system temperature drop.
- F. Determine water flow rate required.
- G. Select terminal units.
- H. Select boiler.
- I. Select expansion tank.
- J. Determine length of circuits.
- K. Make trial selection of pump.
- L. Determine pipe sizes for each trial pump selection.
- M. Make final selection of pump and pipe size and system design.
- N. Make selection of hydronic specialties.

INFORMATION SHEET

XXIII. Integrated water heater/space heating (Transparency 12)

- A. Integrated water heater/space units use a standard domestic water heater along with a hot water coil in an air handler to produce economical space heating.

(NOTE: Items in this objective are adapted from materials published by the First Co., and are reprinted with permission.)

- B. On a call for heat, the wall thermostat energizes a small pump which circulates hot water (135°F to 140°F) from the water heater to the hot water coil in the air handler.
- C. The blower forces cool return air from the home over the hot water coil, the air absorbs heat from the hot water and this warm air (100°F to 110°F) is circulated through the duct system into the home.
- D. In most applications, the water will lose only 10 to 20 degrees in temperature during the heating cycle and will return to the water heater between 120°F and 130°F to be reheated.
- E. A minimum 40-gallon high recovery water heater is recommended for water heater/space heating applications.

(NOTE: Follow manufacturer's recommendations for hot water heater sizing. Savings of more than 30% are possible with a well-planned system.)

XXIV. Pulse combustion boilers (Handout #1)

- A. A pulse combustion boiler is a sealed combustion system that has a high energy efficiency rating because:
1. It has no pilot light.
 2. It has no burners.
 3. Supply and exhaust air are managed through easy-to-install PVC pipe.

(NOTE: Materials in this objective are adapted from manufacturer's literature for the Hydro-Pulse[®] combustion boiler made by Hydrotherm Inc.)

- B. The Hydro-Pulse[®] boiler takes up less floor space than conventional boilers and is sized to service structures ranging from efficiency apartments to larger homes or light commercial structures.
- C. The Hydro-Pulse[®] boiler can also handle residential or commercial hot water needs by being tied into a storage tank where boiler water is circulated through a heat exchanger to heat water. (Figure 1)

INFORMATION SHEET

FIGURE 1

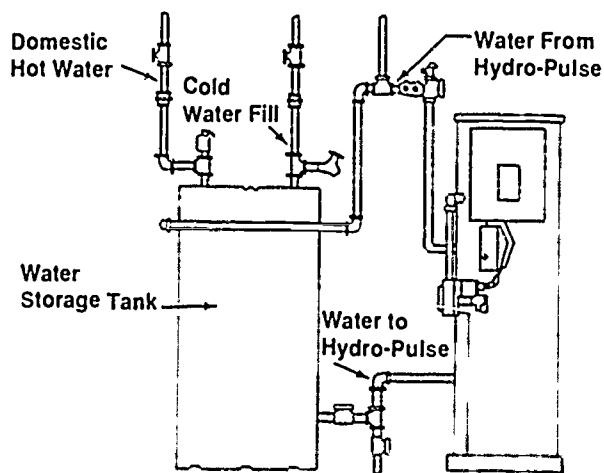

Courtesy Hydrotherm Inc.

- D. The Hydro-Pulse[®] boiler can also be combined with forced air ducted system for a highly efficient hydronic/warm air heating system retrofit. (Figure 2)
- E. In a warm air application, the furnace burners are turned off and only the blower is used to manage heat produced from a hot water heat exchanger coil. (Figure 2)

FIGURE 2

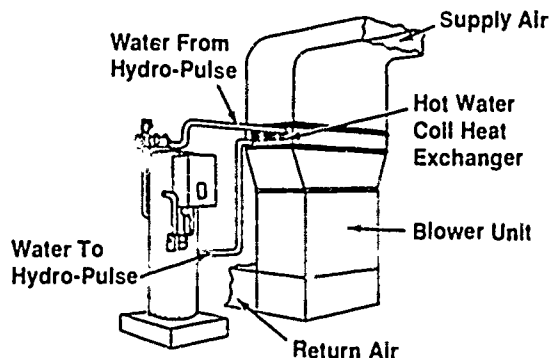

Courtesy Hydrotherm Inc.

XXV. Wall-mounted boilers (Figure 3)

- A. When separate units in an apartment complex or condominium require individual utility metering, wall-mounted boilers can be used.
- B. A wall-mounted unit such as a Celtic[®] boiler by Hydrotherm, Inc., is not only a space saver, it is energy efficient because it requires no flue or chimney.

INFORMATION SHEET

- C. Air intake and exhaust piping for a Celtic[®] unit is accomplished with 4-inch pipe which lowers installation costs and stops up-the-chimney heat losses. (Figure 3)

FIGURE 3

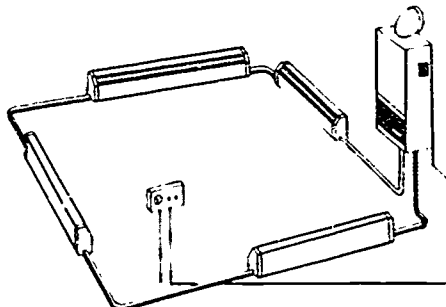

Space Heating Only

Courtesy Hydrotherm Inc.

- D. The Celtic[®] wall-mounted boiler can also be tied in with a hot water storage tank to supply hot water requirements. (Figure 4)

FIGURE 4

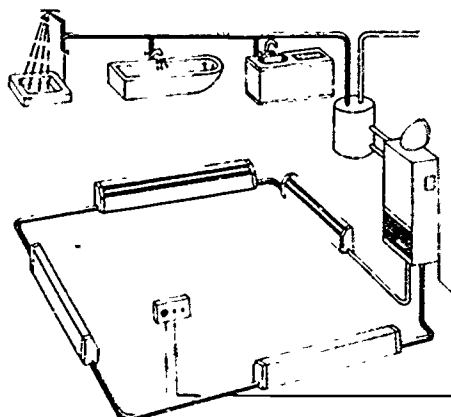

Space & Domestic Water Heating

Courtesy Hydrotherm Inc.

Common Types of Hydronic System Design

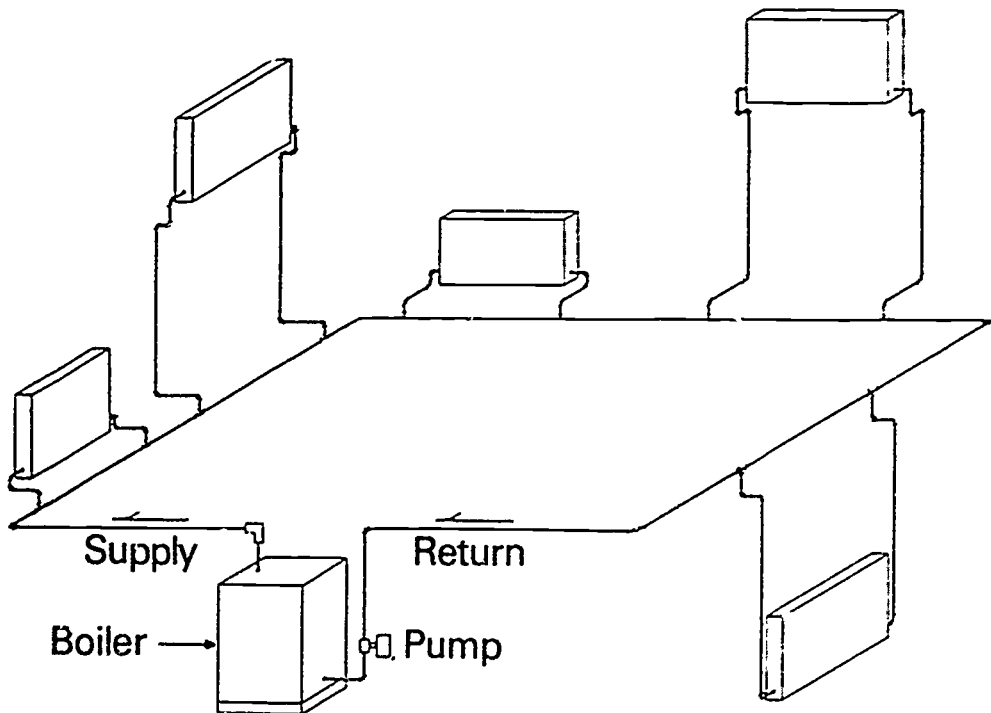
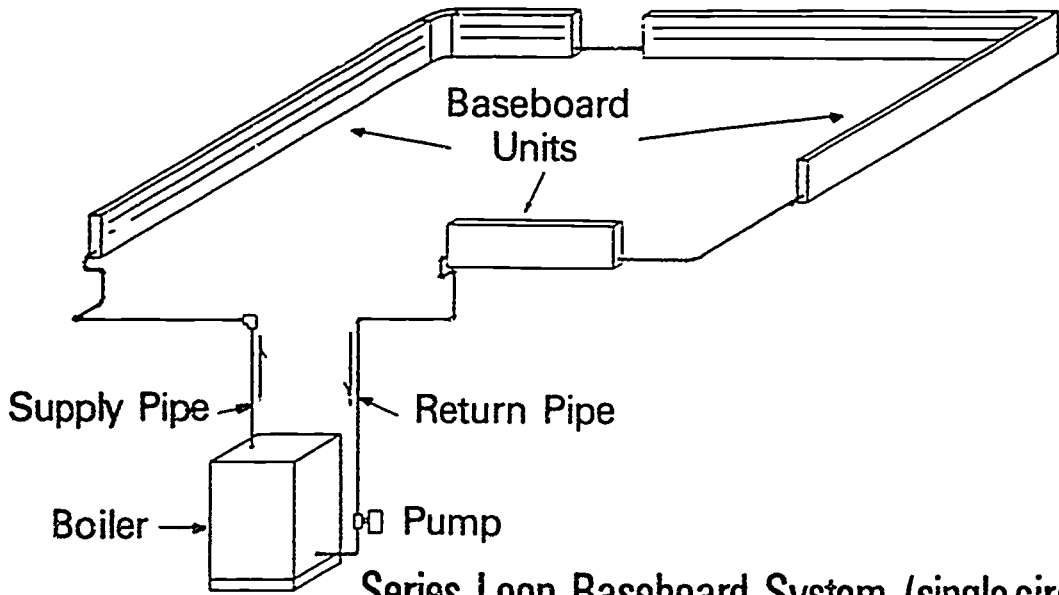

Courtesy North American Heating and Airconditioning Wholesalers Association, NHAW

Common Types of Hydronic System Design (Continued)

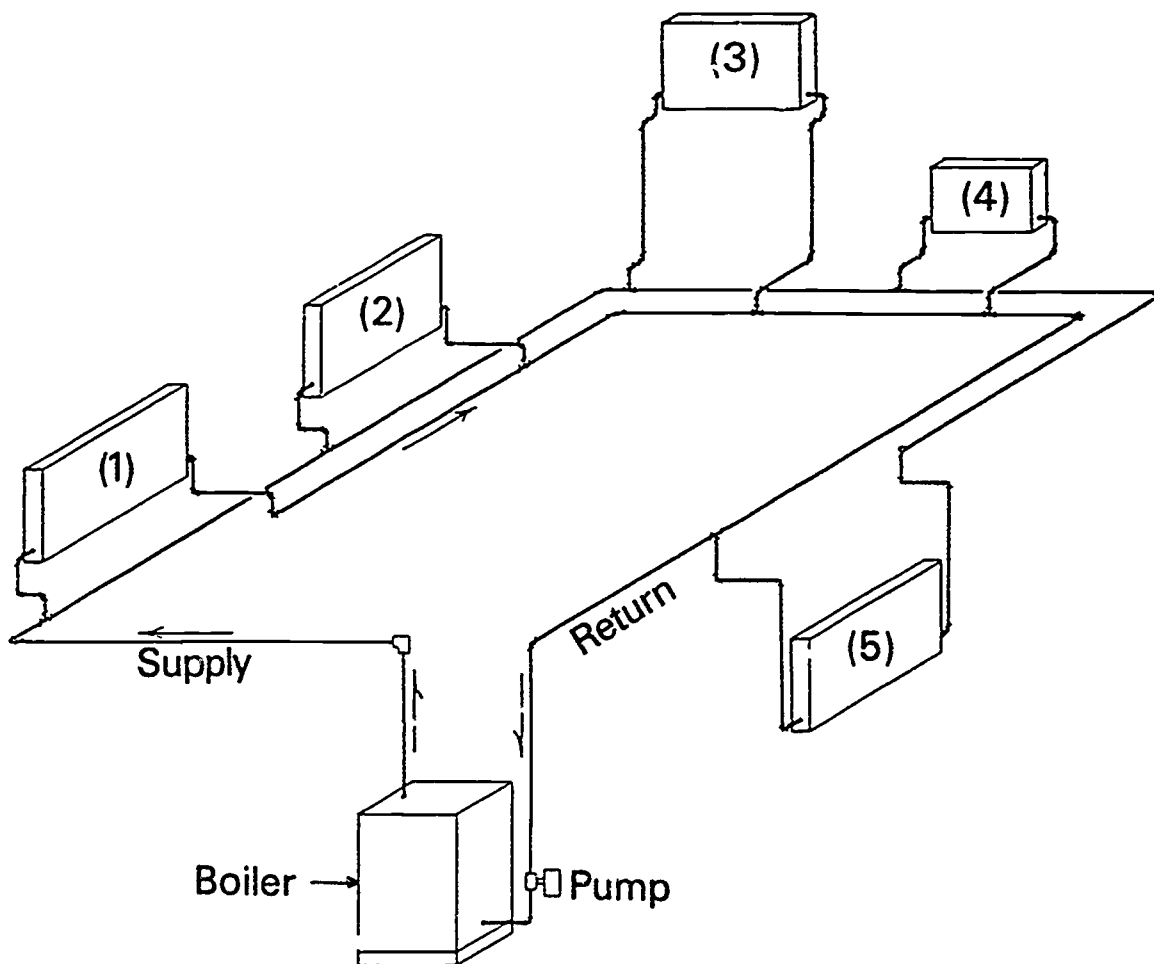

Two Pipe Reverse Return Forced Hot Water Heating System

Courtesy North American Heating and Airconditioning
Wholesalers Association, NHAW

Common Types of Hydronic System Design (Continued)

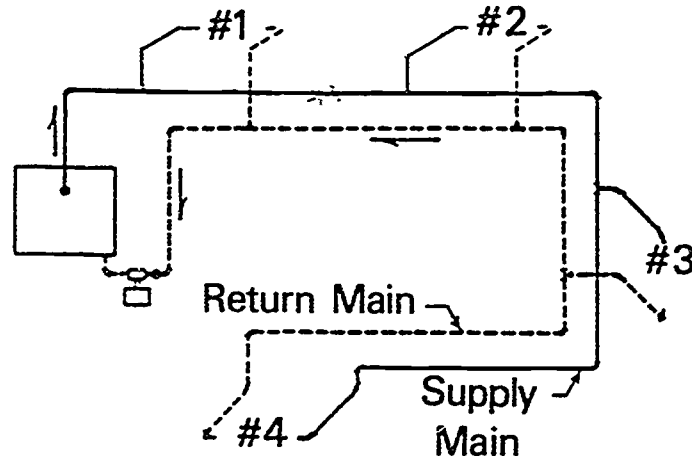

Two Pipe Direct Return Forced Hot Water Heating System

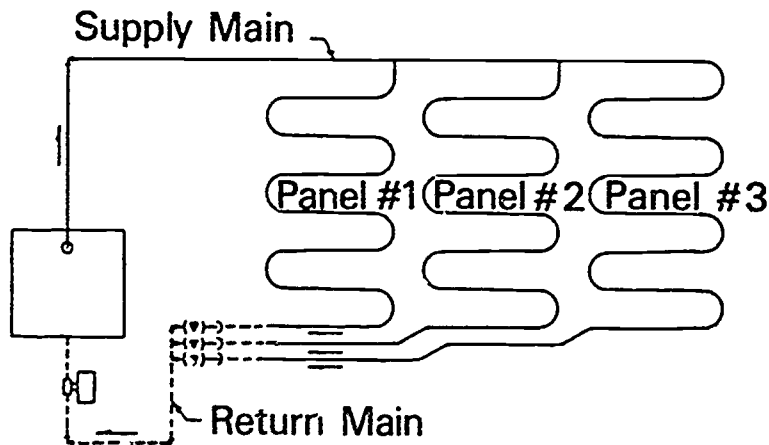

Forced Circulation Hot Water Panel Heating System

Courtesy NorthAmerican Heating and Airconditioning Wholesalers Association, NHAW

Common Types of Hydronic System Design

(Continued)

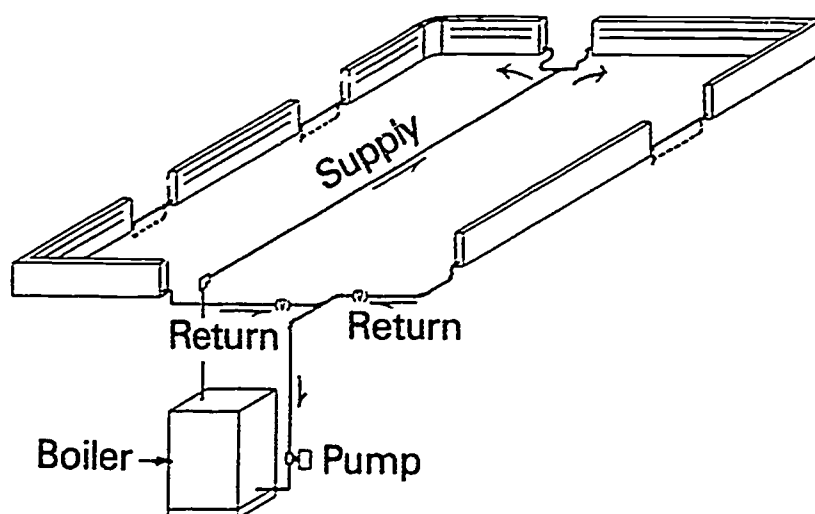

Series Loop Baseboard System – Multiple Circuit

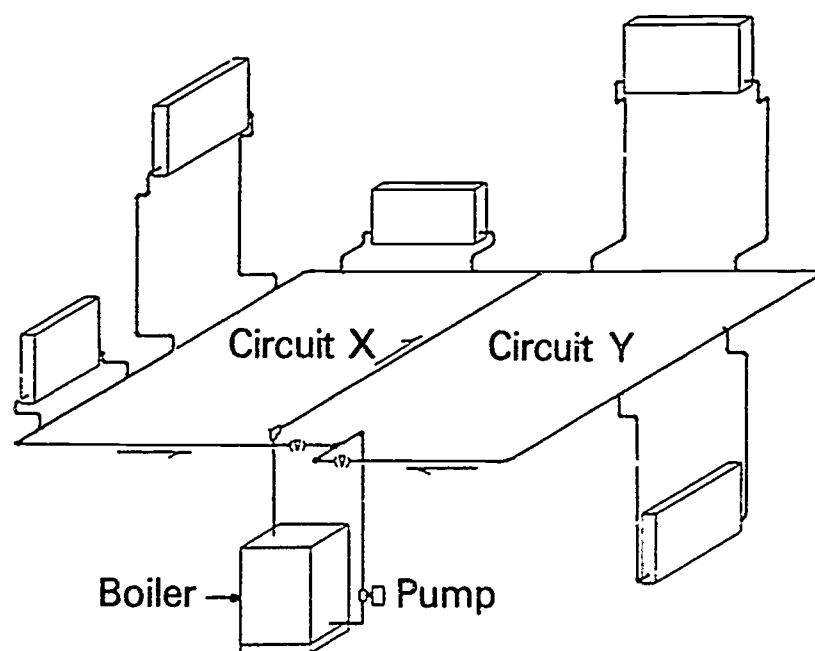

One Pipe Forced Hot Water Heating System – Multiple Circuit

Courtesy NorthAmerican Heating and Airconditioning
Wholesalers Association, NHAW

Types of Cast Iron Radiators and Heat Emission Rates

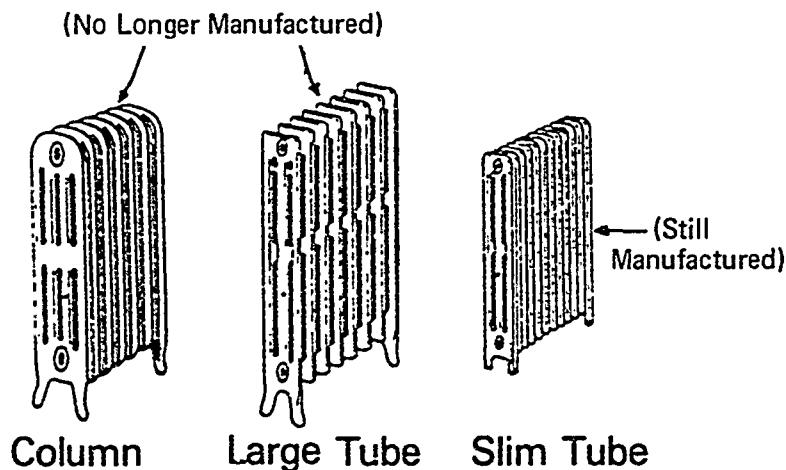

Heat Emission Rates for Cast Iron Radiators

Design or Average Water Temperature	Heat Emission Rates Btu/Hr. per sq. ft.
170	150
175	160
180	170
185	180
190	190
195	200
200	210
205	220
210	230
215	240

Courtesy North American Heating and Airconditioning Wholesalers Association, NHAW

Ratings of Small Tube Radiators — Square Feet

Number of Sections	Length 1 1/4 Inches per Section	3 TUBE	4 TUBE			5 TUBE		6 TUBE		
		25" Height	19" Height	22" Height	25" Height	22" Height	25" Height	19" Height	25" Height	32" Height
2	3 1/2	3.2	3.2	3.6	4	4.2	4.8	4.6	6	7.4
4	7	6.4	6.4	7.2	8	8.4	9.6	9.2	12	14.8
6	10 1/2	9.6*	9.6*	10.8*	12*	12.6*	14.4*	13.8	18*	22.2*
8	14	12.8	12.8	14.4	16	16.8	19.2	18.4	24	29.6
10	17 1/2	16.0*	16.0*	18.0*	20*	21.0*	24.0*	23.0*	30*	37.0*
12	21	19.2	19.2	21.6	24	25.2	28.8	27.6	36	44.4
14	24 1/2	22.4*	22.4*	25.2*	28*	29.4*	33.6*	32.2*	42*	51.8*
16	28	25.6	25.6	28.8	32	33.6	38.4	36.8	48	59.2
18	31 1/2	28.8*	28.8*	32.4*	36*	37.8*	43.2*	41.4*	54*	66.6*
20	35	32.0	32.0	36.0	40	42.0	48.0	46.0	60	74.0
22	38 1/2	35.2*	35.2*	39.6*	44*	46.2*	52.8*	50.6*	66*	81.4*
24	42	38.4	38.4	43.2	48	50.4	57.6	55.2	72	88.8
26	45 1/2	41.6*	41.6*	46.8*	52*	54.6*	62.4*	59.8*	78*	96.2*
28	49	44.8	44.8	50.4	56	58.8	67.2	64.4	84	103.6
30	52 1/2	48.0*	48.0*	54.0*	60*	63.0*	72.0*	69.0*	90*	111.0
32	56	51.2	51.2	57.6	64	67.2	76.8	73.5	96	118.4
34	59 1/2	54.4	54.4	61.2	68	71.4	81.6	78.2	102	125.8
36	63	57.6	57.6	64.8	72	75.6	86.4	82.8	108	133.2
38	66 1/2	60.8*	60.8*	68.4*	76*	79.8*	91.2*	87.4*	114	140.6
40	70	64.0	64.0	72.0	80	84.0	96.0	92.0	120	148.0
42	73 1/2	67.2	67.2	75.6	84	88.2	100.8	96.6	126	155.4
44	77	70.4	70.4	79.2	88	92.4	105.6	101.2	132	162.8
46	80 1/2	73.6	73.6	82.8	92	96.6	110.4	105.8	138	170.2
48	84	76.8	76.8	86.4	96	100.8	115.2	110.4	144	177.6
50	87 1/2	80.0	80.0	90.0	100	105.0	120.0	115.0	150	185.0
52	91	83.2	83.2	93.6	104	109.2	124.8	119.6	156	192.4
54	94 1/2	86.4	86.4	97.2	108	113.4	129.6	124.2	162	199.8
56	98	89.6	89.6	100.8	112	117.6	134.4	128.8	168	207.2

(Note: The Assemblies with a ★ are Considered Stock Assemblies. These Ratings and Stock Assemblies are Based on Simplified Practice Recommendation R-174-47, issued by the U.S. Department of Commerce.)

Courtesy North American Heating and Airconditioning
Wholesalers Association, NHAW

Basic Classes of 'Residential' Baseboard Terminal Units

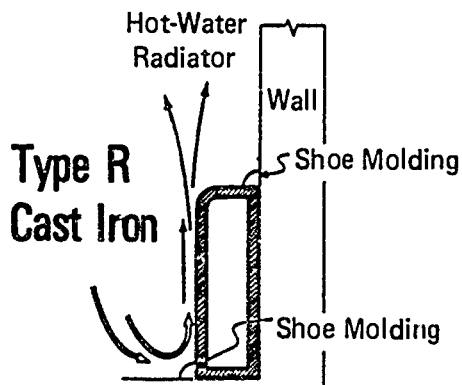

No Longer Manufactured

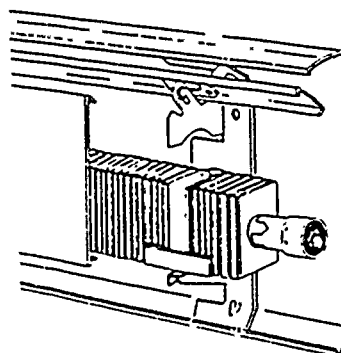
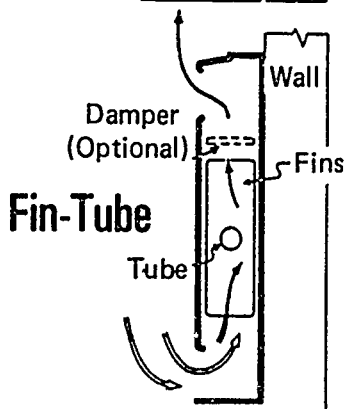
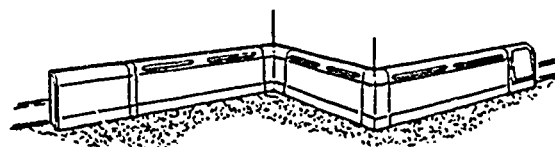
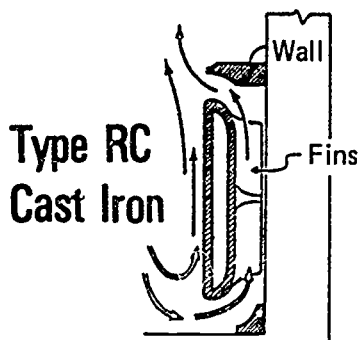

Courtesy NorthAmerican Heating and Airconditioning Wholesalers Association, NHAW

Compression Tank Capacity

Initial or fill, pressure psig	Altitude	Max. height of system above gage ft	Air cushion tank capacity in gallons per gallon of water in system	Diaphragm tank pre-pressurized to 6 psig
4	9	0	0.10	
6	14	5	0.12	
8	18	9	0.15	0.11
10	23	14	0.19	0.14
12	28	19	0.22	0.17
14	32	23	0.26	0.20
16	37	28	0.32	0.24
18	41	32	0.39	0.29
20	46	37	0.48	0.36
22	51	42	0.63	0.47
24	55	46	0.85	0.64

This table is based on a final pressure of 30 psig at the boiler, or low point in the system and an initial fill temperature of 60°F.

Courtesy North American Heating and Airconditioning
Wholesalers Association, NHAW

858

859

Water Content Of Hot Water Systems

Design Load Mbh	Boilers		Radiators		Terminal Units		Radiant Panels	Series Loop	Piping Systems	
	Conventional	Flash	large tube	small tube	Convectors	Baseboard			1-Pipe	2-Pipe
	50	12	5	28	16	7			3	11
60	15	6	34	17	8	4	14	5	9	13
70	17	7	40	20	9	5	16	6	10	15
80	20	8	46	22	10	6	19	7	12	17
90	22	9	51	25	11	7	21	8	13	18
100	25	10	57	28	12	8	24	9	14	21
125	30	11	71	39	18	9	30	11	18	27
150	36	13	86	48	21	10	37	13	22	34
175	42	15	99	55	25	11	44	16	26	40
200	48	16	114	64	29	13	50		30	47
250	60		142	80	36	16	65		39	62
300	70		171	96	43	20	70		49	78
350	84		199	111	50	23			58	94
400	95		228	127	57	26			70	110
450	107		256	143	64	29			80	130
500	120		285	157	71	33			90	150
600	140		342	191	86	39			115	190
700	160		399	223	99	46			140	225
800	190		456	251	114	52			165	260
900	210		513	287	128	59			195	310
1000	235		570	319	142	65			225	360

Table is adapted from Table 1, D27ITT Bell & Gossett "B&G School of Living Comfort"

Courtesy NorthAmerican Heating and Airconditioning
Wholesalers Association, NHAW

Cutaway View of Diaphragm Air Cushion Tank

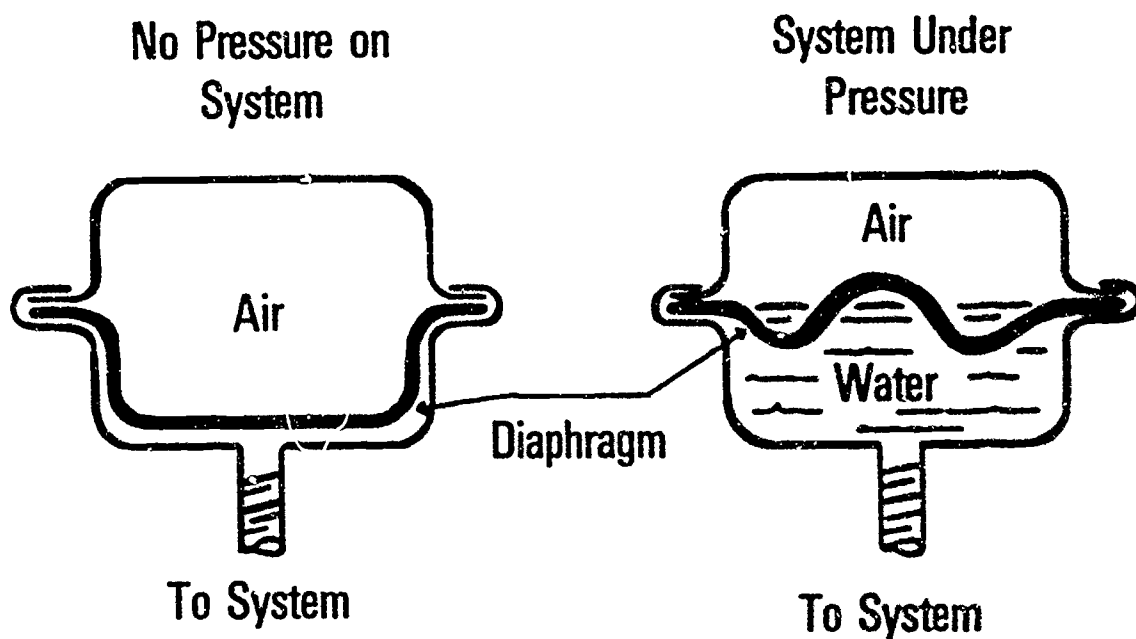

Courtesy North American Heating and Airconditioning
Wholesalers Association, NHAW

ER2

Pipe Sizing-Head Pressure Table

AVAILABLE HEAD ft. of water	TOTAL LENGTH OF CIRCUIT (AS MEASURED ON PIPING LAYOUT)																		
	a	b	c	d	e	f	g	h	i	j	k	l	m	n	o	p	q	r	
4	35	45	50	60	65	70	75	80	90	100	110	130	150	180	220	290	400	620	
5	45	60	65	70	80	90	100	100	120	130	140	160	190	230	290	360	510	790	
6	55	70	80	90	100	110	120	130	140	150	170	190	200	240	290	350	450	620	950
7	65	90	100	110	120	130	140	150	170	190	210	240	290	330	420	540	730	1120	
8	75	100	110	130	140	150	160	180	200	220	250	290	330	400	450	620	850		
9	85	110	130	150	160	170	190	200	230	250	290	330	380	450	550	710	950		
10	100	130	140	170	180	190	210	230	260	290	320	370	430	510	620	790	1060		
11	110	140	160	190	200	220	240	260	290	320	360	410	480	570	690	880	1170		
12	120	160	180	200	220	240	260	290	320	350	400	450	530	620	760	960			
14	150	190	210	250	260	290	310	340	380	420	470	540	620	730	900	1120			
16	170	220	250	290	310	330	350	400	440	490	550	620	720	850	1020				
18	190	250	290	330	350	380	420	450	500	560	620	710	830	950	1150				
20	220	290	320	370	400	430	470	510	560	620	700	790	910	1060					
PIPE SIZE	GALLON PER MINUTE CAPACITIES																		
3/8"	0.9	0.8	0.7	0.7	0.6	0.6	0.6	0.6	0.5	0.5	0.5	0.5	0.4	0.4	0.3	0.3	0.3	0.2	
1/2"	2.3	2.0	1.9	1.8	1.7	1.7	1.6	1.5	1.5	1.4	1.3	1.2	1.2	1.1	0.9	0.8	0.7	0.5	
3/4"	5.0	4.3	4.1	3.8	3.7	3.6	3.4	3.2	3.1	2.9	2.8	2.6	2.4	2.2	2.0	1.8	1.6	1.3	
1"	9.6	8.3	7.7	7.3	7.0	6.8	6.5	6.3	5.9	5.7	5.5	5.0	4.6	4.3	3.8	3.4	2.9	2.3	
1 1/4"	—	18	17	16	15.5	15	14.5	14.0	13.0	12.0	11.5	11.0	9.7	9.0	8.3	7.3	6.3	4.8	
1 1/2"	—	27	25	24	23	22	21	20	19	18	17	16	15	13	12	11	9.3	7.5	
2"	—	—	—	—	—	42	40	39	38	36	34	32	29	27	24	21	18	14	
2 1/2"	—	—	—	—	—	—	—	—	60	57	54	52	47	44	38	32	29	24	

* 3/8" Copper Tubing only

NOTE: Do not go beyond the maximum or below the minimum figures shown in the table.

HOW TO USE THIS TABLE FOR FINAL PIPE SIZE SELECTION

a) Single Pump

Enter the upper portion of the Table at the head pressure of the pump selected. Read across to the figure closest to the total length of circuit. Read down to the lower portion of the Table to the gpm figure equal to or greater than the gpm required for the circuit. Read to the left-hand column to determine the pipe size required. Repeat for each circuit. Staying in the same column established by the circuit with the longest total length, repeat the last step for the gpm requirements of the trunk and distribution piping.

b) Multiple Pumps

Enter the upper portion of the Table at the head pressure of the pump selected. Read across to the figure closest to the total length of the longest circuit served by the pump. Read down to the lower portion of the Table to the gpm figure equal to or greater than the gpm required for the circuit. Read to the left-hand column to determine the pipe size required. For a two-pipe circuit, size all piping in the circuit from the same column in the Table established above. Size the trunk and any distribution piping using the total gpm of the system, the lowest head pressure of the pumps selected, and the longest total length of circuit.

Courtesy NorthAmerican Heating and Airconditioning Wholesalers Association, NHAW

Aquatherm® Water Heater/ Space Heating

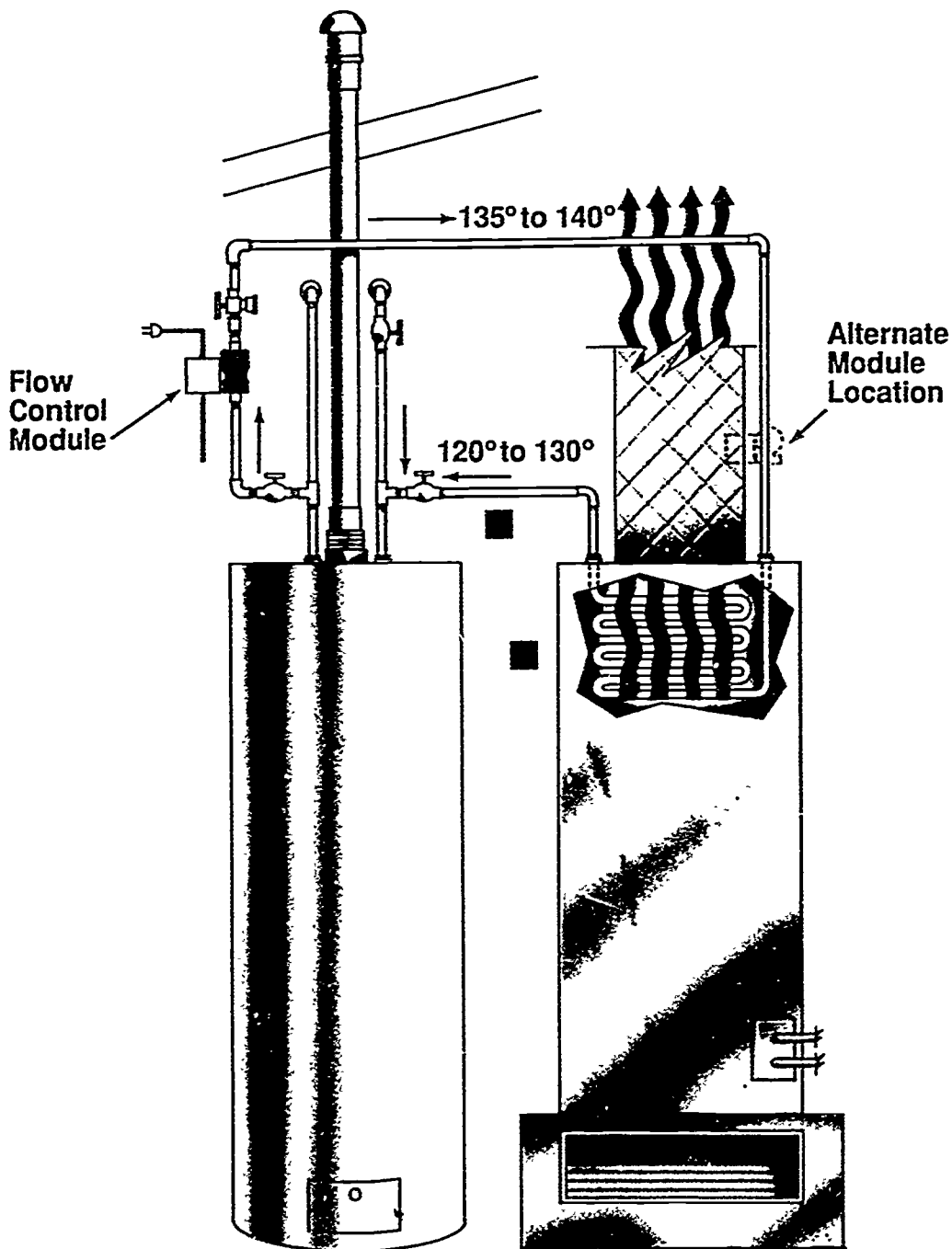

Courtesy FIRST CO., Dallas, Texas

INTRODUCTION TO HYDRONICS UNIT XVI

HANDOUT #1 — THE HYDRO-PULSE®

Purpose

The Hydro-Pulse® boiler from Hydrotherm, Inc., is a new hydronic boiler design that is super efficient, space saving, and designed to fit both residential and light commercial applications. Knowing why and how a pulse boiler works the way it does will help an HVAC technician appreciate advances in hydronic boiler technology.

Air, Gas, and Combustion

Refer to Figure 1 that accompanies this handout as we talk about operating characteristics of the Hydro-Pulse® boiler. The boiler draws air from outside a structure through a small diameter PVC (poly-vinyl-chloride) pipe into its combustion chamber. In the combustion chamber, the air is mixed with gas and ignited by a spark plug on the initial cycle only. After the initial cycle, each following mixture/burn cycle is ignited by heat from the previous cycle.

Hot Gases, Supply Water, and Heat Exchanger

The pressure resulting from the combustion process forces the hot gases down through heat exchanger tubes inside the boiler. In the exchanger tubes, the heat is transferred to the boiler water, which is circulated throughout the structure's heating system (or hot water heat exchanger coil) much in the same manner as with a conventional boiler.

Return Water, Condensation, Exhaust, and Drain

As the hot gases are cooled below the dew point, condensation of the water vapor in the flue gases takes place, releasing latent heat of vaporization, amounting to an increase of more than 9% in the efficiency of the fuel input. The condensate is removed by a drain at the boiler's base while the low temperature exhaust is safely vented outside through a small diameter CPVC (chlorinated-poly-vinyl-chloride) pipe.

Conclusion

The Hydro-Pulse® boiler represents manufacturing concerns for customer demands for equipment that is cleaner and more energy efficient, two important elements in designing new systems and retrofitting older installations.

HANDOUT #1

FIGURE 1

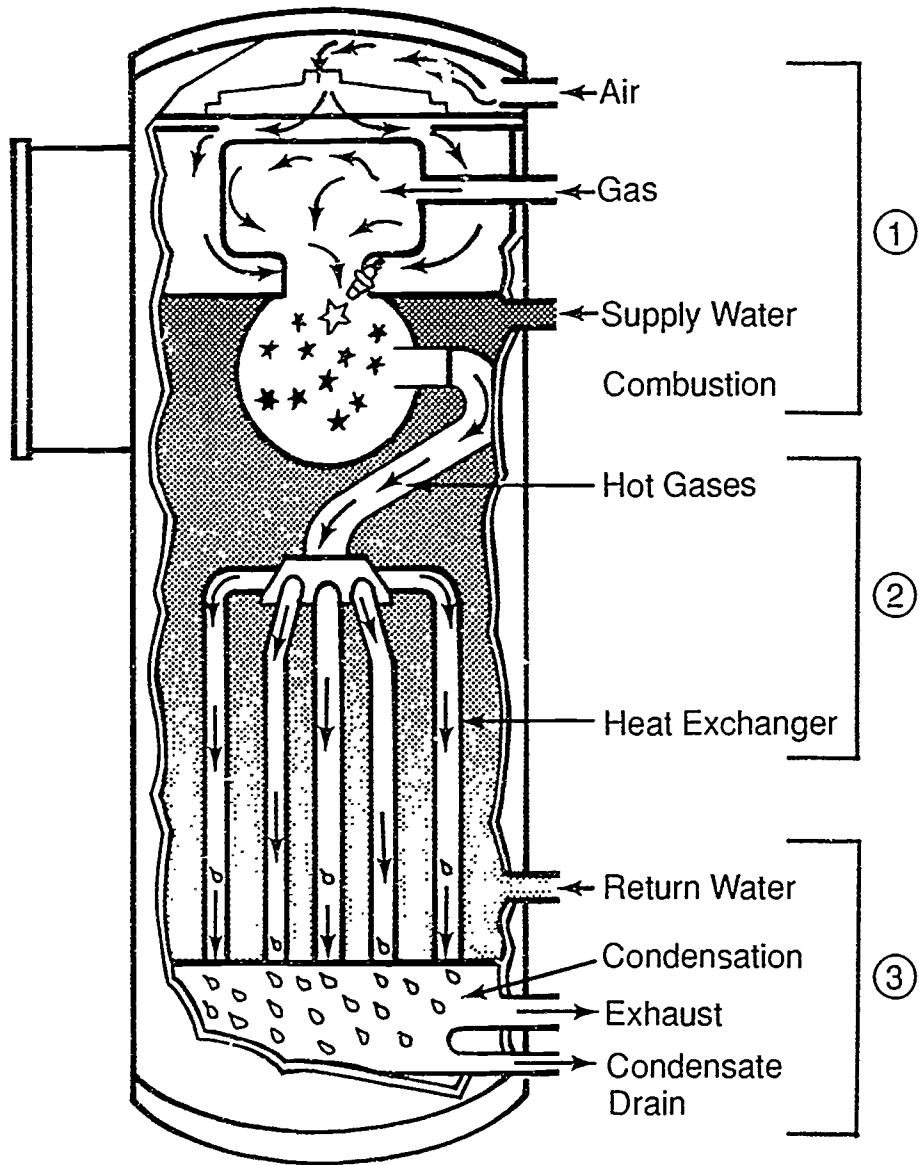

Courtesy of Hydrotherm Inc.

ERG

INTRODUCTION TO HYDRONICS
UNIT XVI

ASSIGNMENT SHEET #1 — LAY OUT A SERIES LOOP SINGLE
CIRCUIT HYDRONIC SYSTEM WITH BOILER LOCATED UNDER
FLOOR OF DINING ROOM

Directions: Use the floor plan below to sketch in the series loop piping, the location of baseboard terminal units, and the kitchen convector; your instructor has the option of modifying this assignment sheet to reflect available systems and local installation practices.

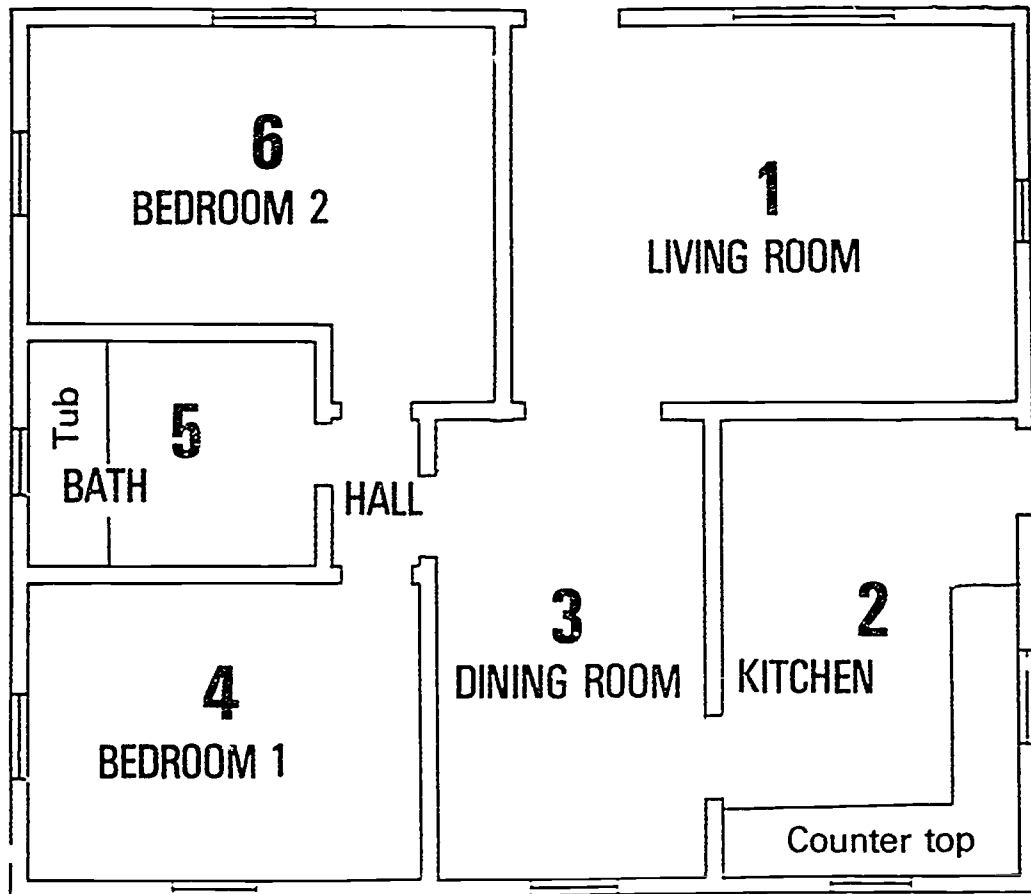

Courtesy NorthAmerican Heating and Airconditioning
Wholesalers Association, NHAW

ASSIGNMENT SHEET #1

Specifications:

Room #1	Living Room	15630 Btuh
Room #2	Kitchen	7540 Btuh
Room #3	Dining Room	8530 Btuh
Room #4	Bedroom #1	7330 Btuh
Room #5	Bath	3250 Btuh
Room #6	Bedroom #2	7220 Btuh
Total Heat Loss		49500 Btuh

Equipment to be located in basement

Design System Temperature 200 degrees

Design Temperature Drop 20 degrees

1. Calculate gpm: _____
2. Select baseboard terminal units from manufacturer's catalog:
Baseboard Model # _____ (See Figure 1)
3. Select convector for Kitchen from manufacturer's literature:
 - a. Kitchen percent of total heat loss: _____ percent
 - b. Kitchen temperature drop: _____ degrees
 - c. Kitchen convector
 - 1) Model # _____ (See Figure 2)
 - 2) Height _____
 - 3) Depth _____
 - 4) Length _____
 - d. Room #1 baseboard length: _____ ft
 - e. Room #3 baseboard length: _____ ft
 - f. Room #4 baseboard length: _____ ft
 - g. Room #5 baseboard length: _____ ft
 - h. Room #6 baseboard length: _____ ft
4. Sketch in on the floor plan the series loop piping and the location of baseboard terminal units and the kitchen convector.

ERS

ASSIGNMENT SHEET #1

FIGURE 1

I = B = R RATINGS per linear feet

DESCRIPTION OF BASEBOARD	WATER				WATER			
	Average Water Temperature °F		Btu/hr. flow rate @		Average Water Temperature °F		Btu/hr. flow rate @	
	150	200	200	220	150	200	220	
No. 7A	150	270	290					
Front outlet	160	325	340					
	170	370	390					
Cast Iron RC	180	420	440					
Height: 7"	190	470	500					
	195	490	520					
	220	520	550					
	210	570	600					
	220	620	640					
	230	660	700					
No. 9A	150	390	410					
Front Outlet	160	450	480					
Cast Iron RC	170	520	550					
	180	590	620					
Height: 9 1/2"	190	650	690					
	195	680	720					
	200	710	750					
	210	770	810					
	220	830	880					
	230	890	940					
88A	150	390	410	200	720	740		
Inclined outlet	155	430	450	205	750	790		
	160	460	490	210	790	840		
1/4" Copper Tubing	165	490	520	215	820	870		
	170	520	540	220	850	900		
175	560	590	225	890	940			
180	590	620	230	920	970			
185	620	640	235	950	1000			
190	660	700	240	980	1040			
195	690	730						
	170	470	500	210	710	750		
	175	500	530	215	740	790		
	180	530	560	220	770	810		
	185	560	590	225	800	850		
	190	590	620	230	830	890		
	195	620	660	235	860	910		
	200	650	690	240	890	940		
	205	680	720					

*These ratings contain an effective heat allowance of 15 percent

FIGURE 2

Entering Air Temperature = 65F Front Outlet Cabinets - Model CF

Temp. Drop F	Height In.	Heating Effect Factor %	Depth In.	Water Temperature - Degrees F											
				180				200				220			
				Length Inches											
				20	24	28	32	20	24	28	32	20	24	28	32
Rated Output - MBh (1000 Btu/h)															
10	20	14.4	4	1.7	2.1	2.5	3.0	2.1	2.6	3.2	3.8	2.5	3.7	3.9	4.5
			6	2.4	3.0	3.7	4.3	3.0	3.8	4.6	5.4	3.7	4.6	5.4	6.6
			8	3.0	3.8	4.6	5.4	3.8	4.8	5.8	6.8	4.6	5.8	7.0	8.3
		10	3.5	4.4	5.3	6.3	4.4	5.6	6.7	7.9	5.3	6.7	8.1	9.5	
	24	10.4	4	1.9	2.4	2.9	3.4	2.4	3.0	3.6	4.3	2.9	3.4	4.4	5.2
			6	2.8	3.6	4.3	5.1	3.6	4.5	5.4	6.4	4.3	5.4	6.6	7.7
			8	3.4	4.2	5.1	6.0	4.2	5.3	6.4	7.5	5.1	6.4	7.8	9.1
		10	3.8	4.8	5.8	6.8	4.8	6.1	7.3	8.6	5.8	7.3	8.9	10.4	
	26	8.4	4	1.9	2.5	3.0	3.5	2.4	3.1	3.7	4.4	2.9	3.7	4.5	5.3
6			2.9	3.7	4.5	5.2	3.7	4.4	5.6	6.6	4.4	5.6	6.8	7.9	
8			3.4	4.4	5.3	6.2	4.3	5.5	6.6	7.8	5.2	6.6	8.0	9.4	
	10	3.9	5.0	6.0	7.0	4.9	6.2	7.5	8.8	6.0	7.5	9.1	10.7		
20	20	14.4	4	1.5	1.8	2.2	2.6	1.8	2.3	2.8	3.3	2.2	2.8	3.4	4.0
			6	2.1	2.7	3.2	3.8	2.7	3.4	4.1	4.8	3.2	4.0	4.7	5.8
			8	2.7	3.4	4.1	4.8	3.3	4.2	5.1	6.0	4.0	5.1	6.2	7.2
		10	3.1	3.9	4.7	5.5	3.9	4.9	5.9	6.9	4.7	5.9	7.1	8.4	
	24	10.4	4	1.7	2.1	2.6	3.0	2.1	2.7	3.2	3.8	2.5	3.2	3.9	4.5
			6	2.5	3.2	3.8	4.5	3.1	4.0	4.8	5.6	3.8	4.8	5.8	6.7
			8	3.0	3.7	4.5	5.3	3.7	4.7	5.7	6.4	4.5	5.6	6.8	8.0
		10	3.4	4.3	5.1	6.0	4.2	5.3	6.5	7.2	5.1	6.4	7.8	9.1	
	26	8.4	4	1.7	2.2	2.4	3.1	2.1	2.7	3.3	3.9	2.6	3.3	3.9	4.6
6			2.6	3.3	3.9	4.6	3.2	4.1	4.9	5.8	3.9	4.9	5.9	6.9	
8			3.0	3.8	4.4	5.4	3.8	4.8	5.8	6.8	4.6	5.8	7.0	8.2	
	10	3.5	4.4	5.3	6.2	4.2	5.5	6.6	7.8	5.2	6.6	8.0	9.4		

Courtesy NorthAmerican Heating and Airconditioning Wholesalers Association, NHAW

ASSIGNMENT SHEET #1

APPROVED I=B=R water ratings

model R-500-A Heatrim-capacities Btu/hr per lineal foot

lineal feet	water flow rate 500 lbs/hr of average water temperature °F						water flow rate 2000 lbs/hr average water temperature °F					
	170°	180°	190°	200°	210°	220°	170°	180°	190°	200°	210°	220°
1	510	570	630	690	750	810	540	600	670	730	790	860
2	1020	1140	1260	1380	1500	1620	1080	1200	1340	1460	1580	1720
3	1530	1710	1890	2070	2250	2430	1620	1800	2010	2190	2370	2580
4	2040	2280	2520	2760	3000	3240	2160	2400	2680	2920	3160	3440
5	2550	2850	3150	3450	3750	4050	2700	3000	3350	3650	3950	4300
6	3060	3420	3780	4140	4500	4860	3240	3600	4020	4380	4740	5160
7	3570	3990	4410	4830	5250	5670	3780	4200	4690	5110	5530	6020
8	4080	4560	5040	5520	6000	6480	4320	4800	5360	5840	6320	6880
9	4590	5130	5670	6210	6750	7290	4860	5400	6030	6570	7110	7740
10	5100	5700	6300	6900	7500	8100	5400	6000	6700	7300	7900	8600
11	5610	6270	6930	7590	8250	8910	5940	6600	7370	8030	8690	9460
12	6120	6840	7560	8280	9000	9720	6480	7200	8040	8760	9480	10320
13	6630	7410	8190	8970	9750	10530	7020	7800	8710	9490	10270	11180
14	7140	7980	8820	9660	10500	11340	7560	8400	9380	10220	11060	12040
15	7650	8550	9450	10350	11250	12150	8100	9000	10050	10950	11850	12900
16	8160	9120	10080	11040	12000	12960	8640	9600	10720	11680	12640	13760
17	8670	9690	10710	11730	12750	13770	9180	10200	11390	12410	13430	14620
18	9180	10260	11340	12420	13500	14580	9720	10800	12060	13140	14220	15480
19	9690	10830	11970	13110	14250	15390	10260	11400	12730	13870	15010	16340
20	10200	11400	12600	13800	15000	16200	10800	12000	13400	14600	15800	17200
21	10710	11970	13230	14490	15750	17010	11340	12600	14070	15330	16590	18060
22	11220	12540	13860	15180	16500	17820	11880	13200	14740	16060	17380	18920
23	11730	13110	14490	15870	17250	18630	12420	13800	15410	16790	18170	19780
24	12240	13680	15120	16560	18000	19440	12960	14400	16080	17520	18960	20640
25	12750	14250	15750	17250	18750	20250	13500	15000	16750	18250	19750	21500
26	13260	14820	16380	17940	19500	21060	14040	15600	17420	18980	20540	22360
27	13770	15390	17010	18630	20250	21870	14580	16200	18090	19710	21330	23220
28	14280	15960	17640	19320	21000	22680	15120	16800	18760	20440	22120	24080
29	14790	16530	18270	20010	21750	23490	15660	17400	19430	21170	22910	24940
30	15300	17100	18900	20700	22500	24300	16200	18000	20100	21900	23700	25800

(NOTE: Approved I=B=R water ratings shown above for American-Standard Heatrim Panels (with Model E-500 element) are based on a water flow of 500 pounds per hour with a pressure drop of 0.260 inches of water per lineal foot and a water flow rate of 2000 pounds per hour with a pressure drop of 2.900 inches of water per lineal foot. As allowed by the Institute of Boiler and Radiator Manufacturers (I=B=R) Testing and Rating Code for Baseboard Type of Radiation, 15% is added to water heat capacity. The use of I=B=R ratings at water flow rates 2000 pounds per hour is limited to installation where the water flow rate through the baseboard unit is equal to or greater than 2000 pounds per hour. Where the water flow rate through the baseboard is not known, the I=B=R rating at the standard water flow of 500 pounds per hour must be used. These ratings are based on active (finned) Heatrim lengths. Difference between active length and total length of the standard Heatrim heating elements is 2 15/22 inches. Elements are unpainted. Non-ferrous fins on Model E-500 elements measure 2 1/8 x 2 1/8 x 0.008 inches, spaced 52 fins per foot.)

Courtesy North American Heating and Airconditioning
Wholesalers Association, NHAW

87.1

**INTRODUCTION TO HYDRONICS
UNIT XVI****ASSIGNMENT SHEET #2 — SELECT BOILER AND EXPANSION TANKS**

Directions: Using a manufacturer's catalog provided by your instructor, select an appropriate boiler and two expansion tanks using the following specifications.

Specifications:

Total Heat Loss:	125,000 Btuh
Design System Temperature:	200 degrees
Design Temperature Drop:	20 degrees
Type of equipment selected:	LTW Boiler
Initial fill pressure:	12 psig
Type of terminal units:	Baseboard
System selected:	Series loop

1. Select boiler from manufacturer's catalog:

Boiler Model No. _____

2. Select conventional air cushion expansion tank.

Minimum tank size: _____ Gal.

3. Select diaphragm tank size.

Minimum Diaphragm tank size: _____ Gal.

INTRODUCTION TO HYDRONICS
UNIT XVI

ASSIGNMENT SHEET #3 — MAKE A TRIAL SELECTION OF PUMP AND
SELECT PIPE SIZE FOR SERIES LOOP SYSTEM

Specifications:

Total heat loss 49500 Btuh
Design System Temperature 200 degrees
Design temperature drop unknown
Total length of system piping design 100 feet

1. Calculate System flow rate in gpm
 - A. @ 10 degrees drop: _____ gpm
 - B. @ 20 degrees drop: _____ gpm
 - C. @ 30 degrees drop: _____ gpm
 - D. @ 40 degrees drop: _____ gpm
 - E. @ 50 degrees drop: _____ gpm
2. Plot gpm on each of the following pump performance curves:

(Example: Plot 14 gpm on sample curve:)

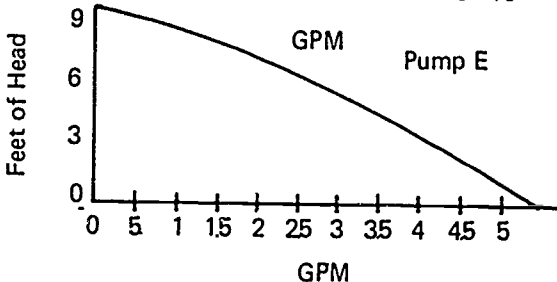
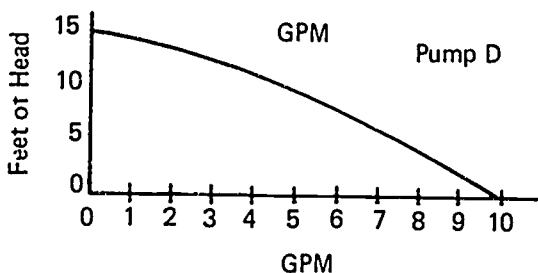
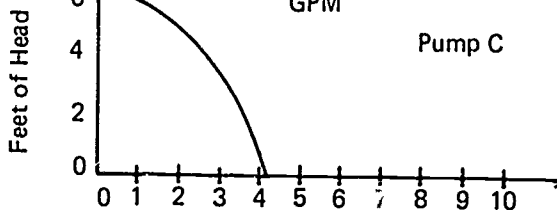
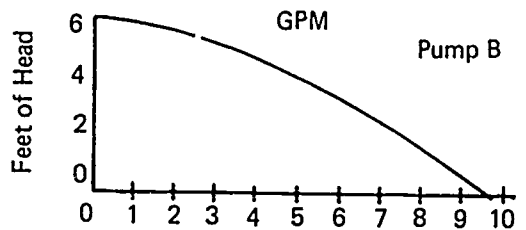
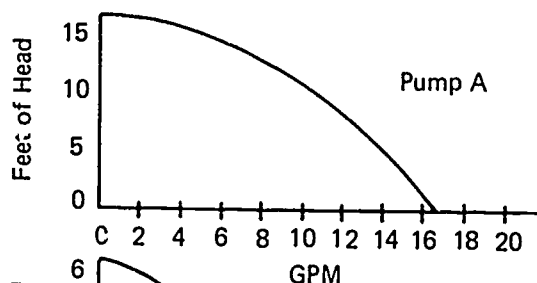
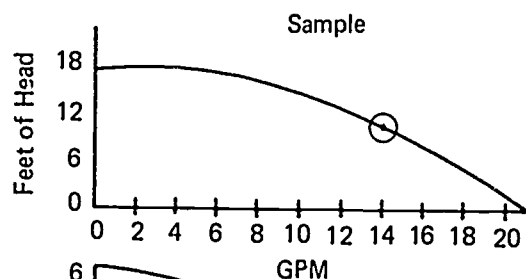

Courtesy NorthAmerican Heating and Airconditioning
Wholesalers Association, NHAW

ASSIGNMENT SHEET #3

3. List available head pressure of each pump selected:

(Example: Sample pump has 12 ft of head pressure at 14 gpm)

Pump A:____, Pump B:____, Pump C:____, Pump D:____, Pump E:____

4. From Table indicate minimum tubing size for each pump: (Refer to Transparency 11)

Pump A:____", Pump B:____", Pump C:____", Pump D:____", Pump E:____"

5. Assume prices of pumps and tubing to be as follows:

Pump A: \$125, Pump B: \$220, Pump C: \$200, Pump D: \$150, Pump E: \$200

1/2" copper tubing: \$40.00 per 100 ft.

3/4" copper tubing: \$60.00 per 100 ft.

1" copper tubing: \$110.00 per 100 ft.

Indicate least expensive combination of pump and tubing which will provide adequate flow of hot water:

Pump: _____ Tubing size: _____ Temperature drop: _____ degrees

INTRODUCTION TO HYDRONICS
UNIT XVI

ANSWERS TO ASSIGNMENT SHEETS

Assignment Sheet #1

1. 5 gpm
2. Answers will vary
3.
 - a. 15.2%
 - b. 3 degrees
 - c.
 - 1) Answers will vary
 - 2) 20, 24, 26
 - 3) 10, 8, 10
 - 4) 32, 32, 28

(NOTE: 24-8-32 is preferred due to thinner configuration.)

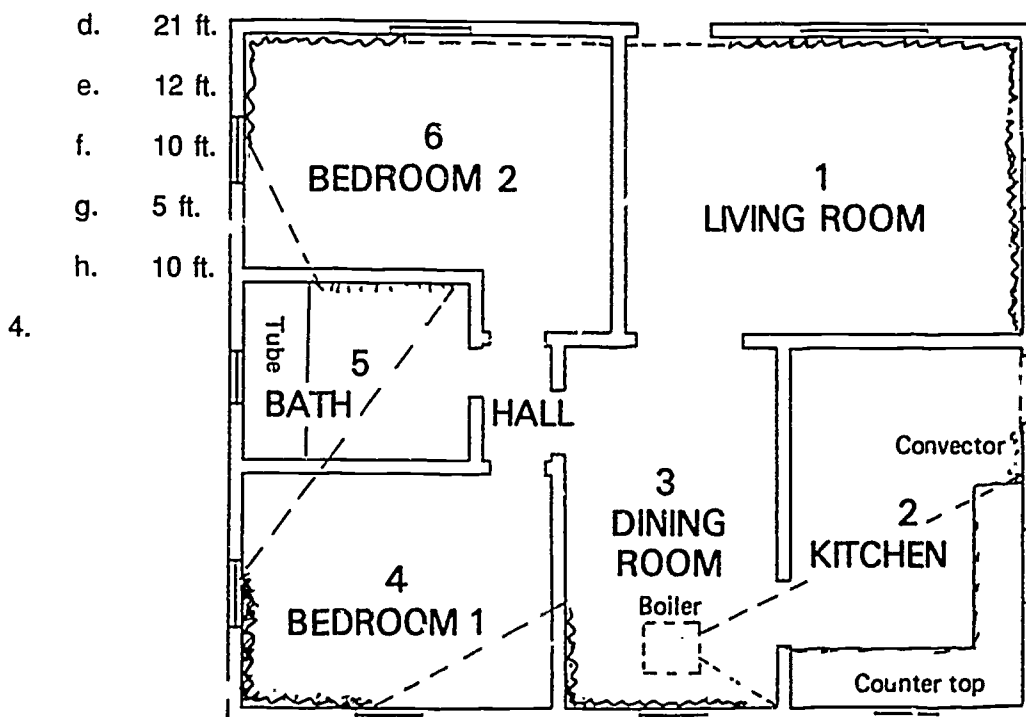

ANSWERS TO ASSIGNMENT SHEETS

Assignment Sheet #2

Answers should be determined by materials provided by instructor

Assignment Sheet #3

1. a. 10 gpm or 9.9 gpm
- b. 5 gpm
- c. 3.3 gpm
- d. 2.5 gpm
- e. 2.0 gpm

2.

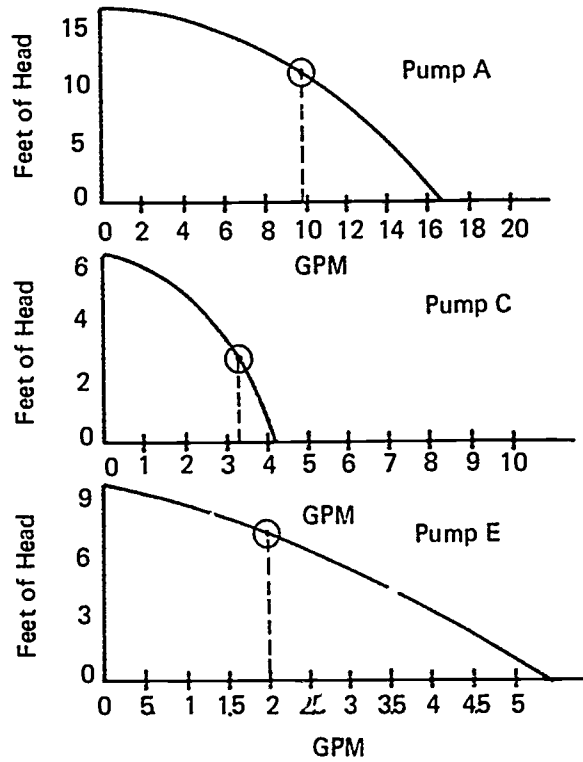
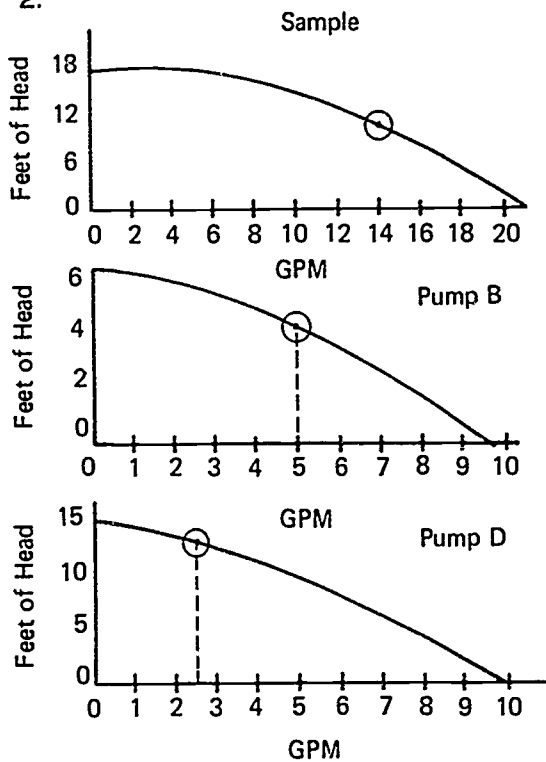

ANSWERS TO ASSIGNMENT SHEETS

Assignment Sheet #3

3.
 - a. 10
 - b. 4
 - c. 3
 - d. 5
 - e. 2
4.
 - a. 1"
 - b. 3/4"
 - c. 3/4"
 - d. 3/4"
 - e. 1/2"
5. Pump D, tubing size 3/4" Temperature drop 20 degrees

INTRODUCTION TO HYDRONICS UNIT XVI

TEST

NAME _____

SCORE _____

1. Match the terms on the right with their correct definitions.

- | | | | |
|-------|--|-----|-------------------------------|
| _____ | a. Transfer heat from the water to the air which is blown through the coil; similar in construction to automobile radiators and located in air ducts | 1. | SBI |
| _____ | b. The pressure exerted by a column of water measured in the height of the water column | 2. | Design water temperature drop |
| _____ | c. System which requires pump pressure for circulation | 3. | MBH |
| _____ | d. A device immersed in a boiler which transfers heat from the boiler to the domestic hot water supply of a structure | 4. | Hot water or steam coils |
| _____ | e. Pounds per square inch of pressure | 5. | Psi |
| _____ | f. Water which has been cooled before circulating through coils for cooling purposes | 6. | Gpm |
| _____ | g. The heat delivered from a hot or warm surface to a cooler surface by radiation of infrared rays | 7. | Terminal units |
| _____ | h. Heat expressed in thousands of Btu's per hour | 8. | Chilled water |
| _____ | i. British thermal units per hour | 9. | Hydronics |
| _____ | j. Flow rate in gallons per minute | 10. | Head |
| _____ | k. Institute of Boiler and Radiator Manufacturers | 11. | Radiant heat |
| _____ | l. A type of pump design where fluid is "thrown" by an impeller rather than pushed by a piston | 12. | IBR |
| | | 13. | Btuh |
| | | 14. | Tankless water heater |
| | | 15. | Centrifugal pump |
| | | 16. | Forced circulation system |
| | | 17. | Integrated systems |
| | | 18. | Pulse combustion boilers |
| | | 19. | Wall-mounted boilers |

TEST

- _____ m. The science of heating with water
 - _____ n. The difference in temperature between supply and return water temperatures at the boiler at design output
 - _____ o. Equipment which releases heat from a hydronic system to a conditioned space
 - _____ p. Boilers whose initial cycle is ignited by a spark, but ensuing mix/burn cycles are ignited by heat from the previous cycle
 - _____ q. Units designed to provide hydronic heating in apartments and condominiums where individual utility metering is required
 - _____ r. Heating systems that combine a hot water supply from a standard water heater with a heating coil in an air handler to provide economical heat through existing ductwork
2. Distinguish between a hydronic gravity system and a forced circulation system. Place an "X" next to the descriptions of a forced circulation system.
- _____ a. Head seldom exceeds 3 to 4 inches in this system.
 - _____ b. When tankless water heater is present, provision must be made to prevent gravity effect during off cycle.
 - _____ c. Head may be 8-15 feet.
 - _____ d. Requires much larger pipe systems.
 - _____ e. Operates on the principle that hot water is lighter than cold water.
 - _____ f. Operates on pump pressure rather than gravity.
 - _____ g. Frequently uses pipe size 3/4" to 1/2".

875

TEST

3. Match the classifications of hydronic systems with their temperature/pressure characteristics.

- | | | |
|---------|---|------------------------------------|
| _____a. | 1) Maximum temperature—250 degrees | 1. Dual temperature system |
| | 2) Maximum pressure—160 psi | 2. Low temperature water system |
| | 3) Usual upper limit—30 psi | 3. Chilled water |
| _____b. | 1) Maximum temperature—350 degrees | 4. Medium temperature water system |
| | 2) Maximum pressure—150 psi | 5. High temperature |
| | 3) Usual design temperature—250 to 325 degrees | |
| | 4) Usual design pressure—150 psi | |
| _____c. | 1) Minimum temperature—Over 350 degrees | |
| | 2) Maximum temperature—400 to 450 degrees | |
| | 3) Usual pressure—300 psi | |
| _____d. | 1) Usual temperature—40 to 50 degrees | |
| | 2) Operating pressure—125 psi | |
| _____e. | 1) Hot and chilled water | |
| | 2) Usual temperatures of 100 to 150 degrees, winter | |
| | 3) Usual temperatures of 40 to 55 degrees, summer | |

TEST

4. Identify the types of common hydronic system designs. Write the system name below its illustration.

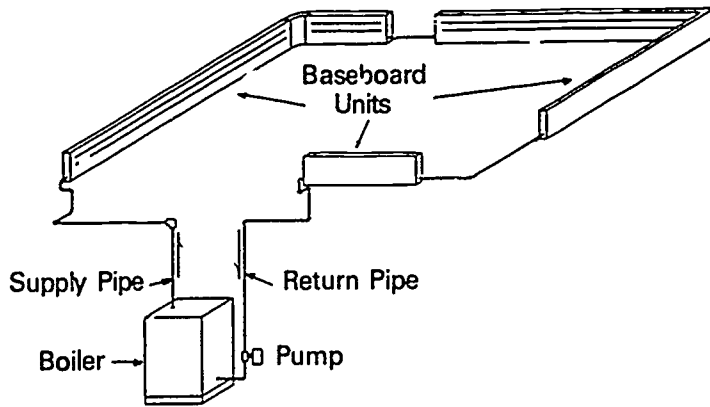

a. _____

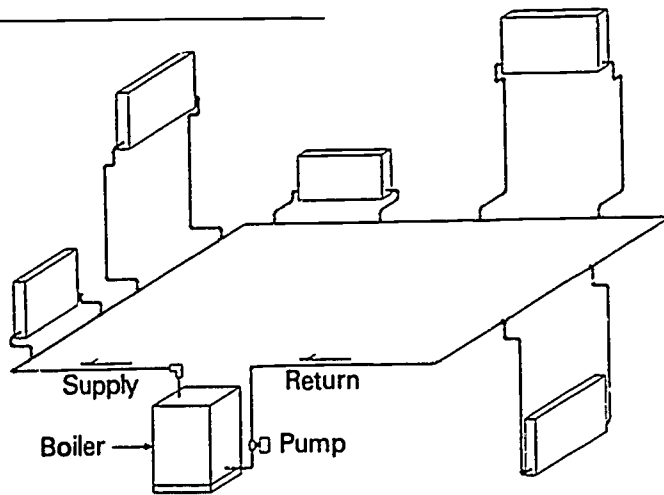

b. _____

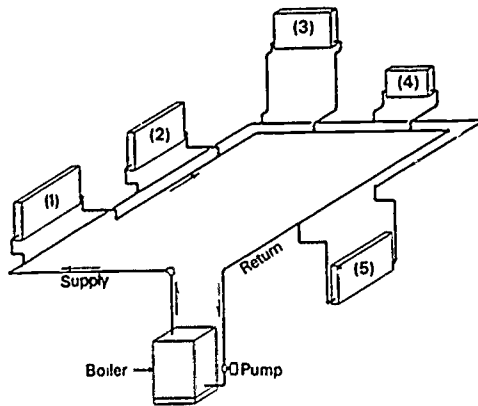

c. _____

880

TEST

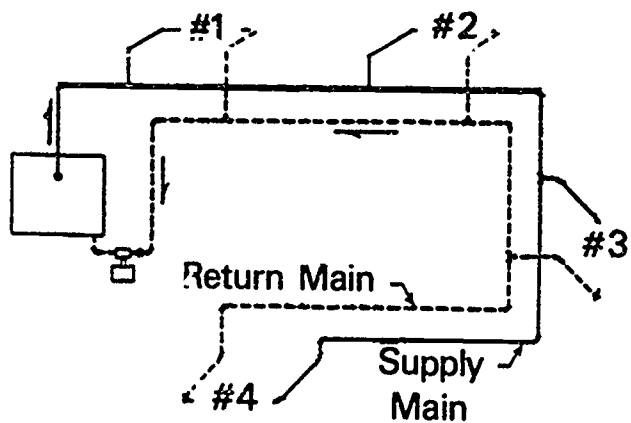

d. _____

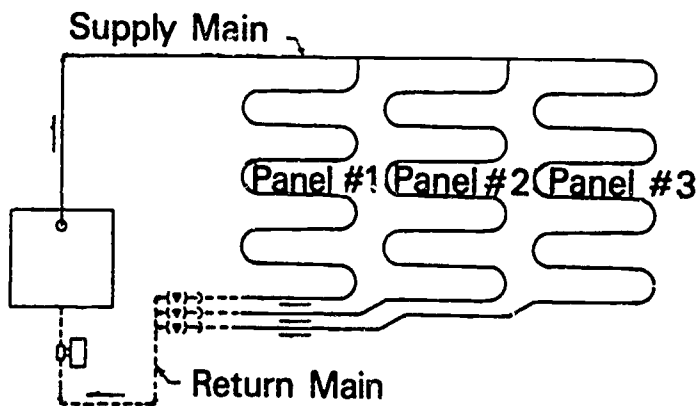

e. _____

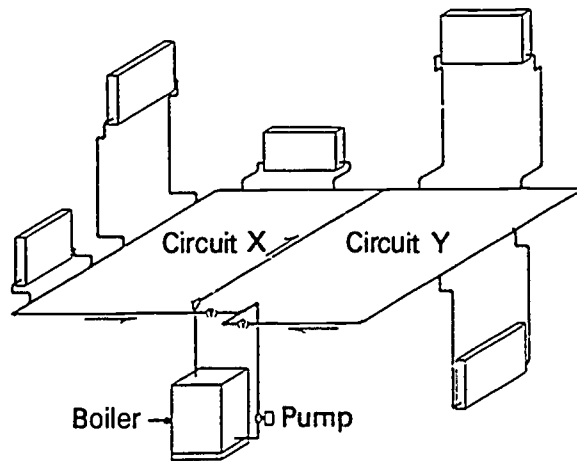
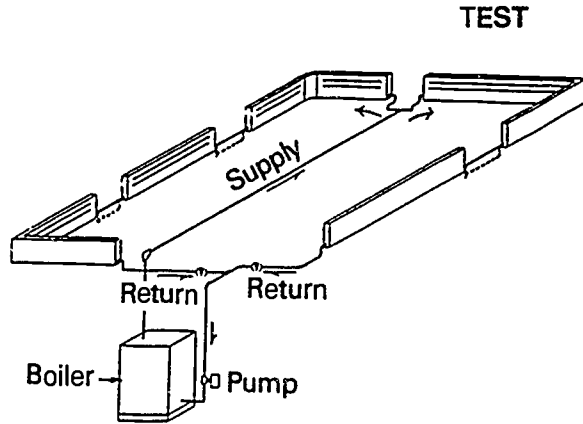

f. _____

5. Match common hydronic system designs with their advantages and disadvantages.

- | | |
|--|---|
| <p>_____ a.</p> <p>1) Advantage — Low installation cost</p> <p>2) Disadvantages</p> <p>a) Water temperature is progressively reduced around circuit requiring allowance for colder water for heating purposes</p> <p>b) Water temperature and rate of flow to any terminal unit within a circuit cannot be regulated without affecting all other terminal units in the circuit</p> <p>c) Tube size in terminal units limits flow of water and capacity of system</p> | <p>1. Multiple circuit systems</p> <p>2. Series loop</p> <p>3. Panel system</p> <p>4. One pipe system</p> <p>5. Two pipe direct return system</p> <p>6. Two pipe reverse return system:</p> |
|--|---|

TEST

- _____ b. 1) Advantage — Possible to control flow and heat from individual terminal units
- 2) Disadvantages
- a) Higher in cost than the series loop system
 - b) Shows progressive drop in temperature around the water circuit
- _____ c. 1) Advantages
- a) Equalizes distance water flows through each terminal unit and equalizes temperature drop
 - b) Eliminates allowance for temperature drop between terminal units
 - c) Individual control of terminal units does not affect other terminal units
- 2) Disadvantage — Additional pipe increases cost
- _____ d. 1) Advantages
- a) Valuable in dual temperature split system
 - b) Lower in cost than reverse return system
- 2) Disadvantages
- a) Creates balancing problems due to different temperature drops across terminal units with low resistance to flow
 - b) Limited applications unless the terminal units have high resistance to flow

TEST

- _____ e. 1) Advantage — Does not interfere with placement of furniture
- 2) Disadvantage — Leaks are expensive to repair
- _____ f. 1) Advantages
- a) Reduces the total length of circuits
- b) Reduces number of terminal units in a circuit
- c) Reduces pipe size of main trunk pipe
- d) Simplifies pipe design in certain types of buildings
- 2) Disadvantage — Could unnecessarily complicate an installation where a simple circuit would be satisfactory
6. Select true statements about design water temperature. Place an "X" beside each true statement.
- _____ a. Design water temperature is used when compensating for temperature drop through series loop circuits.
- _____ b. High temperature requires less radiation equipment.
- _____ c. It determines basis for selection of terminal units.
- _____ d. It does not have an effect on selection of boiler size.
- _____ e. Each circuit of a multiple circuit system may have a different design water temperature.
7. Match the design water temperature drop on the right with the correct terminal unit.
- | | |
|-----------------------------|--------------|
| _____ a. Unit heater | 1. Up to 50° |
| _____ b. Convectors | 2. 30° |
| _____ c. Cast iron radiator | 3. 10° — 30° |
| _____ d. Baseboard | |

TEST

8. Solve the following problem involving design water flow rates through a circuit.

Specifications:

30° temperature drop

Area 1—36,000 BTU's heat loss: _____

Area 2—22,000 BTU's heat loss: _____

Area 3—25,000 BTU's heat loss: _____

What is the design water flow rate through each circuit? _____

9. Match the minimum design flow rate on the right with the correct tubing size.

_____ a.	1/2" tube size	1.	0.9 minimum design gpm
_____ b.	3/4" tube size	2.	0.3 minimum design gpm
_____ c.	1" tube size	3.	1.6 minimum design gpm
_____ d.	1 1/4" tube size	4.	0.5 minimum design gpm

10. Select true statements about the placement of terminal units. Place an "X" beside each true statement.

- _____ a. Terminal units should be placed under wood areas to counteract falling cold air from contact with cold wood.
- _____ b. Terminal units may be placed along outside walls not containing glass.
- _____ c. When outside walls are used to the fullest extent, balance of required terminal unit length may be placed along inside walls.
- _____ d. Long, thin units along walls under windows produce more comfort economically than high, thin units.
- _____ e. A unit on the stair landing will temper or stop the flow of hot air falling down stairs.
- _____ f. Terminal units should distribute heat over the full length of long rooms to prevent spot heat.

TEST

- _____g. Forced air heaters should be installed so that heaters and registers create objectionable blasts of hot air.
- _____h. Combination heating and cooling units require special installation; follow manufacturer's recommendations.

11. Match terminal units with their characteristics and uses.

- | | | |
|---------|--|------------------------|
| _____a. | 1) Column and large tube radiators are no longer manufactured but ratings are based on their performance | 1. Baseboards |
| | 2) Slim tube and wall type radiators are suitable for homes and small office buildings | 2. Air heating coils |
| | 3) May be hung on walls or ceilings where floor space is not available | 3. Convectors |
| | 4) Modern radiators are rated in Btuh per square foot of Equivalent Direct Radiation (EDR) | 4. Cast iron radiators |
| | | 5. Finned tube |
| _____b. | 1) Room air enters at bottom and passes between hot fins to reenter room through outlet at top of device | |
| | 2) Delivers more heat for its size than radiators due to chimney effect of the cabinet | |
| _____c. | 1) Made from hollow cast iron sections | |
| | 2) Made from 3/4" to 1/2" copper tubing with aluminum fins surrounded by sheet metal enclosure with openings at top and bottom | |
| _____d. | Larger diameter, higher capacity commercial equivalents of residential baseboard terminals | |

TEST

12. Complete a list of steps in the selection and sizing of terminal units.
- _____
 - Determine design water temperature.
 - _____
 - Select adequate size terminal from manufacturer's literature.
13. Select true statements concerning fuels, ratings, and selection of boilers. Place an "X" beside each true statement.
- (NOTE: For a statement to be true, all parts of the statement must be true.)
- _____ a. Fuels used for boilers
- Gas
 - Electricity
 - Coal
 - Oil
- _____ b. Ratings are in gross IBR output or net IBR output.
- Gross IBR output is not used for selecting boilers for residential application.
 - Net IBR output is rated in Btuh for water boilers and in square feet of radiator area for steam boilers.
- _____ c. In new construction, select boiler with net rating of 100% of connected load.
- _____ d. In replacement boilers, select a boiler about the size of the old boiler.
14. Distinguish between advantages and disadvantages of types of residential expansion tanks. Place an "X" in all blanks that indicate an advantage.
- a. Open expansion tank
- _____ 1) Permits the expansion of water when heated
 - _____ 2) Lower initial installation cost
 - _____ 3) Allows the evaporation of boiler water which must be replaced
 - _____ 4) Produces boiler scale and loss of efficiency due to the addition of make-up water

TEST

b. Air cushion expansion tank

- _____ 1) Maintains system pressure below safety pressure relief valve setting
- _____ 2) If sized too small it will exceed the setting of the pressure relief
- _____ 3) If sized too large, it can result in noisy operation due to boiling in areas of less pressure
- _____ 4) Water can absorb the air and waterlog the expansion tank over a period of time

c. Air-cushion expansion tank with diaphragm

- _____ 1) Permits smaller tank size due to prepressurization above the diaphragm
- _____ 2) Water cannot absorb the air that is trapped above the diaphragm
- _____ 3) More costly tank over a period of time

15. Select true statements concerning steps in the selection of residential expansion tanks. Place an "X" beside each true statement.

- _____ a. Allow 1 gallon of tank capacity for each 5000 Btuh of total heat loss if conventional tank is used.
- _____ b. Allow 1 gallon of tank capacity for each 7000 Btuh of total heat loss if pressurized diaphragm tank is used, and prepressurized to at least 6 psig.
- _____ c. If calculated tank size is not available, select next size smaller tank.

16. Select true statements about the type, designs, and sizing of residential pumps. Place an "X" beside each true statements.

- _____ a. Residential pumps are usually piston driven.
- _____ b. For a given motor horsepower a pump can be designed to deliver either high volume at low pump head or high pump head at low volume.
- _____ c. Residential pumps are sized from 5 to 150 gallons per minute with head pressures of 4 to 14 feet of head.

17. Complete a list of factors in the selection of residential pumps.

- a. For a given size of piping, pressure drop will increase as rate of flow increases
- b. _____
- c. _____

TEST

18. Arrange in order the steps in selection of residential pumps by placing the correct sequence number in the appropriate blank.
- _____ a. Make selections including consideration of cost of pumps.
 - _____ b. Refer to manufacturer's literature for pump performance curves.
 - _____ c. Determine design rate of flow in gpm.
 - _____ d. Make trial selection of several pumps with various available pump heads at design rate of flow.
 - _____ e. Solve for piping size and select proper pump for most economical total cost of piping and pump.

19. Complete a list of factors affecting pipe sizing.

- a. _____
- b. _____
- c. Available pump head pressure
- d. Cost of pipe and fittings

20. Select true statements concerning the procedure for selection of pipe sizes. Place and "X" beside each true statement.

(NOTE: For a statement to be true, all parts of the statement must be true.)

- _____ a. Refer to pipe sizing table in manufacturer's literature.
- _____ b. Refer to pump manufacturer's pump performance charts.
- _____ c. Plot pipe size curves on pump performance curves for various acceptable sizes of pipe.
- _____ d. Select most economical combination of pipe size and pump size.
- _____ e. If total system cost is not acceptable, select new system design:
 - 1) Increase or decrease number of circuits.
 - 2) Increase or decrease number of pumps.
 - 3) Increase or decrease sophistication of specialty fittings and controls.
 - 4) Increase or decrease design water temperature.
 - 5) Increase or decrease design temperature drop.

TEST

21. Match types of hydronic specialties with their characteristics and uses.

- | | | |
|----------|---|----------------------------|
| _____ a. | 1) Eliminates air absorbed by water | 1. Balancing valves |
| | 2) Usually located at the boiler | 2. Zone valve |
| _____ b. | 1) Eliminates air trapped in system | 3. Air elimination devices |
| | 2) Usually installed in high points in system at terminal units | 4. Pressure relief valve |
| | 3) May be either manually operated or automatic | 5. Fill valve |
| _____ c. | 1) Common globe valve in old manually operated systems | 6. One-pipe fitting |
| | 2) In modern automatic systems the fill valve is a combination pressure reducing valve set at 12 psi combined with a check valve | 7. Air vents |
| | a) Adds water to boiler when pressure drops below set point of fill valve | 8. Flow control valve |
| | b) Prevents boiler water from backing into municipal water system | |
| _____ d. | 1) Used in multiple circuit systems | |
| | 2) Regulates flow rate of water in separate circuits | |
| | 3) Usually inexpensive square head cock valves | |
| | 4) Usually located in return legs of branch circuits at manifold near boiler | |
| _____ e. | 1) Used to prevent gravity effect of rising hot water during off cycle | |
| | 2) Usually a type of weighted check valve with enough resistance to prevent hot water from rising by gravity but will open easily under pump pressure | |

TEST

- _____ f. 1) Used as a safety valve
- 2) Usually comes as part of boiler
- 3) Must be capable of discharging full Btuh rating of boiler in form of steam at a pressure setting 3 psig above rated working pressure of boiler
- 4) Discharge rate is indicated on nameplate of valve
- _____ g. 1) Used in one pipe systems
- 2) Operates as a choke on supply loop to divert water to terminal unit
- _____ h. 1) Used to open or shut off flow of hot water to a zone
- 2) Thermostatically controlled
- 3) Either motorized or solenoid operated

22. Select true statements concerning steps in designing a hydronic system. Place an "X" beside each true statement.

- _____ a. Make trial selection of system design.
- _____ b. Make a layout of piping system.
- _____ c. Calculate heat loss.
- _____ d. Determine Btuh requirements for each circuit or zone of piping system.
- _____ e. Select design system temperature and design system temperature drop.
- _____ f. Determine water flow rate required.
- _____ g. Select terminal units.
- _____ h. Select boiler.
- _____ i. Select expansion tank.
- _____ j. Determine length of circuits.
- _____ k. Make trial selection of pump.

TEST

- _____l. Determine pipe sizes for each trial pump selection.
- _____m. Make final selection of pump and pipe size and system design.
- _____n. Make selection of hydronic specialties.
23. Select true statements concerning integrated water heater/space heating. Place an "X" beside each true statement.
- _____a. Integrated water heater/space heating units use a standard domestic water heater along with a hot water coil in an air handler to produce economical space heating.
- _____b. On a call for heat, the wall thermostat energizes a small pump which circulates hot water (135°F to 140°F) from the water heater to the hot water coil in the air handler.
- _____c. The blower forces cool return air from the home over the hot water coil, the air absorbs heat from the hot water and this warm air (100°F to 110°F) is circulated through the duct system into the home.
- _____d. In most applications, the water will lose only 10 to 20 degrees in temperature during the heating cycle and will return to the water heater between 120°F and 130°F to be reheated.
- _____e. A minimum 30-gallon high recovery water heater is recommended for water heater/space heating applications.
24. Solve problems concerning pulse combustion boilers. Select the best solution to each of the following.
- a. You have told a customer that a pulse combustion furnace is highly efficient and the customer wants to know why. You should say _____.
- 1) They're simply designed better.
 - 2) They have no pilot light, no burners, no flue, and are less expensive to operate.
 - 3) They are smaller.

TEST

- b. You have a customer interested in a pulse combustion boiler, but the customer says his present system is a warm air system and it would be too expensive to replace it with a hydronic system. You should say _____.
- 1) That's right.
 - 2) The pulse system is expensive, but worth it.
 - 3) The pulse boiler is ideal for retrofit because present gas burners can be turned off and only the blower used to manage heat produced from a hot water heat exchanger.
25. Solve problems concerning wall-mounted boilers. Select the best solution to each of the following.
- a. A condominium developer asks your company to bid on heating units for a project. You know that individual utility metering will be required for each unit. You recommend wall-mounted boilers because of their convenience, but what else should you say? _____.
- 1) That the work is guaranteed.
 - 2) That installation costs are less expensive and that up-the-chimney heat loss is eliminated.
 - 3) That the units are finished in baked enamel and look great.
- b. The owner of a small apartment wants a new heating unit, but is worried about space in a small apartment. You point out the space-saving features of a wall mounted unit, but you could also add _____.
- 1) The units can be tied into a water storage tank to also provide an economic hot water supply.
 - 2) The units can be installed with good looking baseboard heating units.
 - 3) The installation time will be minimal and interrupt the customer less than four hours.

(NOTE: If the following activities have not been accomplished prior to the test, ask your instructor when they should be completed.)

26. Lay out a series loop single circuit hydronic system with boiler located under floor of dining room. (Assignment Sheet #1)
27. Select a boiler and expansion tanks. (Assignment Sheet #2)
28. Make a trial selection of a pump and select pipe size for series loop system. (Assignment Sheet #3)

INTRODUCTION TO HYDRONICS
UNIT XVI

ANSWERS TO TEST

1. a. 4 h. 3 o. 7
 b. 10 i. 13 p. 18
 c. 16 j. 6 q. 19
 d. 14 k. 12 r. 17
 e. 5 l. 15
 f. 8 m. 9
 g. 11 n. 2
2. b, c, f, g
3. a. 2
 b. 4
 c. 5
 d. 3
 e. 1
4. a. Series loop
 b. One pipe system
 c. Two pipe reverse return system
 d. Two pipe direct return system
 e. Panel system
 f. Multiple circuit systems
5. a. 2
 b. 4
 c. 6
 d. 5
 e. 3
 f. 1
6. b, c, e
7. a. 1
 b. 3
 c. 2
 d. 1
8. 5.5 gpm

ANSWERS TO TEST

9. a. 2
b. 4
c. 1
d. 3
10. b, c, d, f, h
11. a. 4
b. 3
c. 1
d. 5
12. a. Determine room heat loss and MBH
b. Determine design temperature drop
13. a, b, c
14. a. 1, 2 b. 1 c. 1, 2
15. a, b
16. b, c
17. b. For a given rate of flow, pressure drop will decrease as size of pipe increases
c. There will always be more than one combination of pipe size and pump head which will produce required water flow rate
18. a. 4
b. 2
c. 1
d. 3
e. 5
19. a. Rate of flow in gallons per minute
b. Length of pipe circuit in feet of pipe
20. a, b, c, d, e

ANSWERS TO TEST

21. a. 3 e. 8
 b. 7 f. 4
 c. 5 g. 6
 d. 1 h. 2
22. a, b, c, d, e, f, g, h, i, j, k, l, m, n
23. a, b, d
24. a. 2
 b. 3
25. a. 2
 b. 1
26. Evaluated according to answers to assignment sheets.
27. Evaluated according to answers to assignment sheets.
28. Evaluated according to answers to assignment sheets.



CUSTOMER RELATIONS UNIT XVII

UNIT OBJECTIVE

After completion of this unit, the student should be able to discuss the ways individual work habits contribute to good customer relations, and list solutions for special problems in customer relations. These competencies will be demonstrated by completing the assignment sheet and by scoring a minimum of 85 percent on the unit test.

SPECIFIC OBJECTIVES

After completion of this unit, the student should be able to:

1. Match terms related to customer relations with their definitions.
2. List ways good personal habits contribute to good customer relations.
3. Select true statements concerning general rules in dealing with customers.
4. Select true statements concerning basic rules for service calls.
5. Complete statements concerning ways to turn service calls into good customer relations opportunities.
6. Select true statements concerning ways to handle an irritated customer.
7. Complete statements concerning ways vehicle operations affect customer relations.
8. Solve problems concerning ways to earn a customer's respect.
9. Respond to problem situations. (Assignment Sheet #1)

**CUSTOMER RELATIONS
UNIT XVII****SUGGESTED ACTIVITIES**

- A. Obtain additional materials and/or invite resource people to class to supplement/reinforce information provided in this unit of instruction.

(NOTE: This activity should be completed prior to the teaching of this unit.)

- B. Provide students with objective sheet.
- C. Discuss unit and specific objectives.
- D. Provide student with information and assignment sheets.
- E. Discuss information and assignment sheets.
- F. Integrate the following activities throughout the teaching of this unit:
1. Invite the public relations director of a local business to talk to the class about the importance of public relations and customer relations.
 2. Invite the owner or manager of a local business that has company vehicles to talk to the class about vehicle use and care.
 3. Meet individually with students to evaluate their progress through this unit of instruction, and indicate to them possible areas for improvement.
- G. Give test.
- H. Evaluate test.
- I. Reteach if necessary.

REFERENCES USED IN DEVELOPING THIS UNIT

- A. Swenson, S. Don. *Troubleshooting and Servicing Air Conditioning Equipment*. Belmont, CA 94002: Wadsworth, Inc., 1985.
- B. Eckes, William, and Dan Fulkerson. *Air Conditioning and Refrigeration, Book Four*. Stillwater, OK 74074: Mid-America Vocational Curriculum Consortium Inc., 1981.

**CUSTOMER RELATIONS
UNIT XVII**

INFORMATION SHEET

I. Terms and definitions

- A. **Customer relations** — The personal on-the-job performance and related activities by business owners and their employees that instill in a customer a sense of value, satisfaction, and trust
- B. **Personal Hygiene** — The attention a person pays to habits that promote cleanliness, good health, and psychological well being
- C. **Word-of-mouth advertising** — What customers or clients of a business or service tell their friends about the service they received or the product they bought

II. Ways good personal habits contribute to good customer relations

- A. Every hour you're on the job, your appearance and behavior contribute to the company image.
- B. Off the job, positive remarks about your work and your company contribute to good customer relations.

(NOTE: Positive word-of-mouth advertising is the best kind of advertising, and it not only comes from satisfied customers, it can also be generated by concerned employees.)

- C. Personal hygiene not only contributes to good personal appearance, it creates a psychological well being needed in dealing with daily stress and many different types of customers.
- D. Good work habits begin with being on time and help contribute to the accurate and efficient work that impresses and satisfies customers.
- E. Respect for company vehicles and equipment reflects a concern that customers unconsciously relate to.
- F. Respect for customer property inspires customer respect in return.

III. General rules in dealing with customers

- A. Be courteous at all times, especially when circumstances have created an unpleasant situation.

(NOTE: It's easy to be courteous when things are going well; it takes character to be courteous in tough situations.)

INFORMATION SHEET

- B. Treat all service calls as emergencies.

(NOTE: Except for maintenance, most service calls are made to correct situations that are causing people inconvenience or discomfort.)

- C. Respect scheduling commitments.

(NOTE: If unexpected problems on one call mean you'll be late getting to a second scheduled call, phone the second customer or have the office phone to explain the delay and set a new time.)

- D. Keep your personal problems to yourself; you're there because the customer has problems.
- E. Avoid socializing after the job is done; time spent drinking coffee or iced tea with a customer can be used to better personal and company advantage.
- F. Never make commitments to a customer without company approval.

IV. Basic rules concerning service calls

- A. Check the truck to make sure you won't be leaving a track of mud or leaking oil on a customer's driveway.
- B. Check your own appearance and make sure your feet are clean.
- C. Identify yourself, your company, and state that you are there to service a specific problem.

(NOTE: Many service calls are made during times when a housewife is home alone; proper identification eases anxieties associated with inviting strangers into the home.)

- D. Politely ask questions to establish what the problem is, when it started, how many times it has happened, and at what times of day it is most noticeable.
- E. Tell the customer you have an idea of what the problem is and can probably have the equipment in operation again in a short while.

(NOTE: Don't pinpoint the problem because it could turn out to be something else and cause the customer to doubt that you know what you're doing.)

- F. When the work is finished, make sure the work area is clean and that all parts and covers are back in place.
- G. Assure the customer that the equipment is working well and explain what caused the failure and anything the customer can do to help prevent its happening again.

INFORMATION SHEET

- H. Even if billing is done from the office, tell the customer what was wrong, what replacement parts you used, and leave the old parts for the customer to examine, unless warranty requires parts be returned.

V. Ways to turn service calls into good customer relation opportunities

- A. Leave the company name and telephone number with the customer; if the company has a sticker, suggest it be placed in the front of the phone book with the emergency numbers.
- B. Show the customer how easy it is to change filters and explain how clean filters improve equipment performance and save money and energy.
- C. Show the customer proper thermostat operation, especially if the thermostat has an energy-saving design.

(NOTE: When these activities are completed after the bill is presented, it leaves the customer with a feeling that you have contributed an extra service free of charge — and you have.)

VI. Ways to handle an irritated customer

- A. Show your concern by listening carefully.
- B. Show your concern by taking notes of specific items in the complaint; this helps keep the matter on a business level.
- C. Let the customer state the entire problem.

(NOTE: Call it "blowing off steam" or "getting it out of your system," this usually permits a customer to cool off.)

- D. In cases where the situation involves equipment still under warranty, assure the customer that the part will be replaced if the warranty is still in effect.
- E. In cases where the situation involves a misunderstanding concerning an entire contract, assure the customer that a salesman or the company owner will contact them as soon as possible.

(NOTE: In these cases, it is wise to call the office immediately and try to set a specific day and hour for the meeting.)

- F. Apologize for any inconvenience and assure the customer that the company will look into the matter as soon as possible.

VII. Ways vehicle operations affect customer relations

- A. Trucks and vehicles with the company name on them are mobile advertisements and should be kept clean and in good repair.

INFORMATION SHEET

- B. Trucks and vehicles should be driven safely and courteously; accidents or even incidents create a damaging public image.
- C. Intoxicants, drugs, profanity, and horseplay do not belong around business, and especially not around company vehicles.

VIII. Ways to earn a customer's respect

- A. Wear clean clothes or a clean uniform daily.
- B. Always carry a cleaning rag to wipe greasy fingerprints off thermostats or equipment covers.
- C. Carry a drop cloth to use in situations where dust or dirt might fall on a carpet or finished hardwood floor.
- D. Do not smoke or use other forms of tobacco while on a service call.

**CUSTOMER RELATIONS
UNIT XVII****ASSIGNMENT SHEET #1 — RESPOND TO PROBLEM SITUATIONS**

Directions: Based on information contained in this unit, respond in writing or role play the method you would use to relate to specific problem situations with customers.

1. The customer is pleased that you repaired the air conditioner in less than an hour, and invites you to coffee and doughnuts. What is the best response?
2. You are on a service call and realize that you are going to be only 20 minutes late to your next service call. What is the best response?
3. You are on a service call in a situation where the customer is not at home, and an early check of the problem indicates that repairs will cost a great deal more than the customer is probably anticipating. What is the best response?
4. The customer is pleased that you repaired the air conditioner in less than an hour, but indicates the unit is old and costing too much in repairs. At this point, the customer invites you to have a cup of coffee so he or she can ask some questions about new equipment. What is the best response?
5. You are sent on a service call at 2:30 in the morning and arrive to find that the only problem is that someone (maybe a child) has turned the thermostat down too low, and the customer jokes that surely there will be no charge for correcting something that simple. What is the best response?
6. You are sent on a service call only to find that the customer is disturbed with the entire performance of equipment the company has installed, and is obviously irritated with the company, their work, and their service. The customer especially complains that the company has not lived up to its contract guarantees. What is the best response?

**CUSTOMER RELATIONS
UNIT XVII**

ANSWERS TO ASSIGNMENT SHEET #1

1. Indicate that you have other service calls to make, and politely excuse yourself from the invitation.
2. Even if you're only going to be a few minutes late, call the office and have someone inform the next customer that you're going to be a little late.
3. Contact the customer before you begin any repairs that will cost considerably more than the customer anticipates. If you cannot contact the customer personally, have someone at the office do it.
4. Anytime a customer indicates an interest in add-on or new equipment, take the time to listen to the problem and take notes, and make sure the information gets to the supervisor or the sales manager as soon as possible.

(NOTE: It is common practice with many companies to pay service personnel cash bonuses for leads that result in sales of new equipment.)

5. The charge for service calls is set by the company. The customer should be told this as politely as possible as the bill is presented.
6. Hear the customer out, then contact the office and set up a date for the owner or a salesman to visit with the customer as soon as possible.

**CUSTOMER RELATIONS
UNIT XVII**

TEST

Name _____ Score _____

1. Match the terms on the right with their correct definitions.

<p>_____ a. The personal on-the-job performance and related activities by business owners and their employees that instill in a customer a sense of value, satisfaction and trust</p> <p>_____ b. The attention a person pays to habits that promote cleanliness, good health, and psychological well being</p> <p>_____ c. What customers or clients of a business or service tell their friends about the service they received or the product they bought</p>	<p>1. Personal hygiene</p> <p>2. World-of-mouth advertising</p> <p>3. Customer relations</p>
--	--

2. Solve problems concerning ways personal habits contribute to good customer relations. Select the best solution to each of the following problems.
 - a. You're new on a job and you like the company. What can you do to impress others of your interest? _____
 - 1) Tell them what a great company you work for.
 - 2) Start by getting to work on time.
 - 3) Write a short note to your boss.

 - b. You and another company technician have finished a job and you want to stop for a cold drink at a nearby fast-food restaurant. The truck is covered with mud from the days driving. What should you do? _____
 - 1) Park the truck out of sight and walk to the restaurant.
 - 2) Take the truck to a carwash and then park a clean truck close to the restaurant where everyone can see the company name.
 - 3) Forget the whole thing and go back to the shop.

3. Select true statements concerning general rules in dealing with customers. Place an "X" beside each true statement.
 - _____ a. Be courteous at all times, especially when circumstances have created an unpleasant situation.

 - _____ b. Treat all service calls as emergencies.

TEST

- _____c. Respect scheduling commitments, but if you have to be late don't worry because people expect that.
- _____d. Keep your personal problems to yourself; you're there because the customer has problems.
- _____e. Take time to drink coffee or iced tea with a customer; this lets them know you're friendly.
- _____f. Never make commitments to a customer without company approval.
4. Select true statements concerning basic rules for service calls. Place an "X" beside each true statement.
- _____a. Check the truck to make sure you won't be leaving a track of mud or leaking oil on a customer's driveway.
- _____b. Check your own appearance and make sure your feet are clean.
- _____c. Identify yourself, your company, and state that you are there to service a specific problem.
- _____d. Politely ask questions to establish what the problem is, when it started, how many times it has happened, and at what times of day it is most noticeable.
- _____e. Tell the customer you know exactly what the problem is and can probably have the equipment in operation again in a short while.
- _____f. When the work is finished, make sure the work area is clean and that all parts and covers are back in place.
- _____g. Assure the customer that the equipment is working well and explain what caused the failure and anything the customer can do to help prevent its happening again.
- _____h. Even if billing is done from the office, tell the customer what was wrong, what replacement parts you used, and leave the old parts for the customer to examine, unless warranty requires parts be returned.
5. Complete statements concerning ways to turn service calls into good customer relations opportunities. Circle the material that best completes each statement.
- a. Leave the company name and telephone number with the customer; if the company has a sticker, suggest it be placed in the front of the phone book with the (emergency numbers) (area code information).
- b. Show the customer how easy it is to change filters and explain how clean filters (improve) (maintain) equipment performance and save money and energy.

TEST

- c. Show the customer proper thermostat operation, especially if the thermostat has (an energy-saving design) (several features).
6. Select true statements concerning ways to handle an irritated customer. Place an "X" beside each true statement.
- ____ a. Show your concern by listening carefully.
- ____ b. Show your concern by taking notes of specific items in the complaint; this helps keep the matter on a business level.
- ____ c. Do not let the customer state the entire problem; this is usually a waste of time.
- ____ d. In cases where the situation involves equipment still under warranty tell the customer the manufacturer will have to take care of it.
- ____ e. In cases where the situation involves a misunderstanding concerning an entire contract, assure the customer that a salesman or the company owner will contact them as soon as possible.
- ____ f. Apologize for any inconvenience and assure the customer that the company will look into the matter as soon as possible.
7. Complete statements concerning ways vehicle operations affect customer relations. Circle the material that best completes each statement.
- a. Trucks and vehicles with the company name on them are (easy to see) (mobile advertisements) and should be kept clean and in good repair.
- b. Trucks and vehicles should be driven safety and courteously; accidents or even incidents create a damaging (public image) (insurance cost).
- c. Intoxicants, drugs, profanity, and (carelessness) (horseplay) do not belong around business, and especially not around company vehicles.
8. Solve problems concerning ways to earn a customer's respect. Select the best solution to each of the following problems.
- a. As you're getting ready to leave a job, you notice a co-worker has left fingerprints on a thermostat. What do you do? _____.
- 1) Forget it.
- 2) Remind your co-worker that fingerprints should be cleaned off equipment.
- 3) Wipe the fingerprints off and remind your co-worker that technicians are supposed to carry a cleaning rag for just that purpose.

TEST

- b. You are in a situation where you feel that dust off the top of a furnace may fall off onto the hall carpet. What do you do? _____.
- 1) Keep tools away from the top of the furnace.
 - 2) Use a drop cloth to protect the carpet.
 - 3) Use a cleaning cloth to clean the top of the furnace.

(NOTE: If the following item has not been accomplished prior to the test, ask your instructor when it should be completed.)

9. Respond to problem situations. (Assignment Sheet #1)

303

**CUSTOMER RELATIONS
UNIT XVII****ANSWERS TO TEST**

1. a. 3
b. 1
c. 2

2. a. 2
b. 2

3. a, b, d, f

4. a, b, c, d, f, g, h

5. a. Emergency numbers
b. Improve
c. An energy-saving design

6. a, b, e, f

7. a. Mobile advertisements
b. Public image
c. Horseplay

8. a. 3
b. 2

9. Evaluated according to answers to assignment sheet



SERVICE OPERATIONS UNIT XVIII

UNIT OBJECTIVE

After completion of this unit, the student should be able to list the objectives of good service operations and discuss the forms and processes that are used in operations. These competencies will be demonstrated by completing the assignment sheet and by scoring a minimum of 85 percent on the unit test.

SPECIFIC OBJECTIVES

After completion of this unit, the student should be able to:

1. Match terms related to service operations with their correct definitions.
2. Complete statements concerning objectives of good service operations.
3. Select true statements concerning guidelines for maintaining inventory control.
4. Select true statements concerning guidelines for maintaining records of installations, service calls, and maintenance calls.
5. Complete statements concerning ways to gather information for a good equipment file.
6. Select true statements concerning the procedure for handling return goods.
7. Select true statements concerning special precautions in handling return goods.
8. Select true statements concerning vehicle use, maintenance, and safety.
9. Select true statements concerning basic rules for scheduling and service calls.
10. Complete statements concerning ways to avoid legal problems with equipment and service.
11. Match other operations items with how they contribute to good service operations.
12. Select true statements concerning how to handle accounting and money with service customers.
13. State the most important rule of good service operations.
14. Complete a return goods tag. (Assignment Sheet #1)

**SERVICE OPERATIONS
UNIT XVIII**

SUGGESTED ACTIVITIES

- A. Obtain additional materials and/or invite resource people to class to supplement/reinforce information provided in this unit of instruction.
- (NOTE: This activity should be completed prior to the teaching of this unit.)
- B. Provide students with objective sheet.
- C. Discuss unit and specific objectives.
- D. Provide students with information and assignment sheets.
- E. Discuss information and assignment sheets.
- F. Integrate the following activities throughout the teaching of this unit:
1. Invite a factory or distributor representative to discuss warranties and problems that arise from improper installation or misunderstanding.
 2. Invite a local HVAC contractor to talk to the class about the importance of service calls and what they mean to company success.
 3. Meet individually with students to evaluate their progress through this unit of instruction, and indicate to them possible areas for improvement.
- G. Give test.
- H. Evaluate test.
- I. Reteach if necessary.

REFERENCES USED IN DEVELOPING THIS UNIT

- A. Swenson, S. Don. *Troubleshooting and Servicing Air Conditioning Equipment*. Belmont, CA 94002: Wadsworth, Inc., 1985.
- B. Eckes, William, and Dan Fulkerson. *Air Conditioning and Refrigeration, Book Four*. Stillwater, OK 74074: Mid-America Vocational Curriculum Consortium Inc., 1981.

SERVICE OPERATIONS UNIT XVIII

INFORMATION SHEET

I. Terms and definitions

- A. **Service operations** — The ordered activities of accounting, scheduling, inventory control, and personnel supervision that contribute to safe and effective performance, good customer relations, and continued sales and service
- B. **Equipment file** — A file for retaining records of the type of heating and cooling equipment each customer has
- C. **Suspense file** — A file used to remind people of important things to do at specific future dates
- D. **Warranty** — A written statement that a piece of equipment installed to manufacturer's specifications will be guaranteed for a specific length of time

II. Objectives of good service operations

- A. Maintain proper records of in-house and mobile inventory.
- B. Maintain proper records of installations, service calls, and maintenance calls.
- C. Maintain helpful records concerning customer equipment and warranties.
- D. Maintain records to assist in follow-up contact with customers who have indicated interest in add-on or new equipment.
- E. Promote punctuality and professional performance with careful scheduling.
- F. Promote safety on the job and the safe use of company vehicles.
- G. Maintain professional standards that will eliminate the prospects of customer complaints or costly legal activity.
- H. Maintain records which will assist in evaluating employee performance.

III. Guidelines for maintaining inventory control

- A. Inventory forms should be carried in every service vehicle.
- B. Service personnel should record parts and materials used on every job, and submit a complete inventory report after every major job.
- C. Service personnel should include in the inventory report a list of tools or equipment lost or damaged or any equipment that needs repair.

INFORMATION SHEET

IV. Guidelines for maintaining records of installations, service calls, and maintenance calls

- A. All installations should be recorded on a form suitable for filing and include:
1. Customer's name, address and phone number
 2. Date of installation
 3. Company job number
 4. All technical information concerning basic equipment and system design, including sizes of belts and filters
 5. All equipment or component warranties
 6. A signed statement from the installation supervisor that the customer has been instructed in correct operation and maintenance of the system
- B. All service calls should be recorded on a form suitable for filing and include:
1. Customer's name, address and phone number
 2. Date of service call
 3. Company job number
 4. Customer complaint
 5. Description of the problem
 6. How the problem was corrected and the parts or materials used to repair or replace equipment
 7. Who made the service call and how long it took
 8. A record of the expense to the customer, broken down to show cost of individual items and labor charges
 9. All information available concerning type of equipment, its approximate age, and any discussions service personnel had with the customer concerning add-on or replacement equipment
- C. All maintenance calls should be recorded on a form suitable for filing and include:
1. Customer's name, address and phone number
 2. Date of maintenance call
 3. Company job number

913

INFORMATION SHEET

4. Name of person making the call
5. List of all charges to the customer

V. Ways to gather information for a good equipment file

- A. Encourage service personnel to observe basic equipment and system design on each call.
- B. Have service personnel record type of equipment, Btuh ratings, and approximate age of equipment.
- C. Have service personnel report any information the customer volunteers concerning problems with equipment.
- D. Have service personnel report any conversations where customers showed an interest in add-on or new equipment.
- E. List any unusual belt or filter sizes so that on future service calls, the service truck won't have to make an extra trip back to the stockroom for supplies.

VI. Procedures for handling return goods

- A. Make sure the warranty has not expired.
- B. Fill out the return goods tag, and be sure it includes:
 1. Date and address of installation
 2. Date of equipment start-up
 3. Time service person spent on replacement
 4. Serial number
 5. Brief statement of reasons for failure
 6. Any information which would assist the manufacturer in checking the malfunction
- C. Separate the dealer and manufacturer tags from the return tag and turn the dealer and manufacturer tags into the office.
- D. Attach the return tag to the defective component; the tags usually have a wire or a strong cord especially for this purpose, and should be tied securely so they won't come loose in transit.
- E. Do not remove data plates.

INFORMATION SHEET

VII. Special precautions in handling return goods

- A. Make sure serial numbers of the component are recorded on all three parts of the return tag, the return tag itself, the part for the dealer's files, and the part that goes back to the manufacturer.
- B. Double check the component to be returned to make sure the malfunction is permanent.

(NOTE: When a manufacturer finds returned goods are not defective, the company is still charged with the cost.)

- C. Read return procedures carefully and make sure return goods are sent to the correct place.

(NOTE: To reduce freight costs, many return goods are not sent back to the manufacturers, but to local or area wholesalers who are equipped to spot check the goods for defects.)

- D. If there are no written return procedures, call or write the manufacturer for directions.

VIII. Vehicle use, maintenance, and safety

- A. All vehicles should be safety checked daily, and the check should include:

- 1. Brakes and brake lights
- 2. Lights and turning signals
- 3. Oil and antifreeze
- 4. Tires

- B. Start and return mileage should be recorded daily and signed by the operator.

- C. Maintenance schedules for oil change, tire rotation, tune up, etc., should be left in the glove compartment of each vehicle and checked at least once a week by the operator.

- D. City and state maps should be kept in the glove compartment of each vehicle along with a city phone book.

(NOTE: City phone books that contain area maps are essential in larger cities.)

- E. Mobile radio equipment should be checked out daily.

- F. Vehicles should be washed as needed, waxed, and shined at regular intervals.

(NOTE: This is not only a part of vehicle maintenance, it's a part of company image maintenance.)

INFORMATION SHEET

IX. Basic rules for scheduling and service calls

- A. All service personnel should know the day before where their first call will be the next morning and any other than normal parts or materials they need to take with them.
- B. All service personnel should know the addresses of additional calls they are expected to make that day, and should inform the office immediately of any situation that creates a need for rescheduling.
- C. Service personnel going directly to a job site rather than the shop at the beginning of the work day should inform the shop of their arrival at the job site.
- D. In situations where a house has to be unlocked by an occupant who is at work, or by a neighbor, the office should contact the party and inform them what time the service person will arrive.
- E. In situations where a customer cannot be home while service work is being performed, the service person should call the customer on arrival to confirm the nature of the trouble, and inform the customer when the work is completed and what was done.
- F. Make certain the customer gives advance approval of any unexpected increase in costs, especially if the customer has been given an estimate of repair costs, and especially if the cost increase will be considerable.
- G. Curious children are intrigued with tools and equipment, and parents should be asked politely, in the interest of safety, to keep children away from the work area.

X. Ways to avoid legal problems with equipment and service

- A. Use equipment that is listed by a national testing company.

(NOTE: Underwriter's Laboratories is a typical national testing company, when a piece of equipment is UL approved, it means it is backed by engineering experts and legal counsel; use of unlisted components or materials is not recommended.)

- B. Install all wiring to code and customer specifications.
- C. Install all equipment according to manufacturer's specifications.

(NOTE: An incorrect installation could void equipment warranty, and create legal problems.)

- D. Never bypass or jump a part.

(NOTE: Bypasses such as copper links for fuses can easily be spotted even after a bad fire.)

- E. Replace all covers and secure them well.

(NOTE: Loose covers invite the attention of children and also permit dust and dirt to settle on components.)

INFORMATION SHEET

XI. Other operations items and how they contribute to good service operations

- A. **Daily reports** — These record the daily activity of individual service people, assist with scheduling by recording who does what kind of job best, and provide a basis for evaluating employee performance
- B. **Suspense file** — Should remind you to make 30, 60, and 90-day phone checks with customers who have new installations, can help to remind a customer that a warranty period is about to expire, and can be used for follow-up contact with service customers who have asked about add-on or new equipment
- C. **Job orders** — These provide service people with information concerning customer's name, address, nature of the complaint, the time the customer expects the service call to be made, and assigns a job number for the purposes of bookkeeping and accounting

XII. How to handle accounting and money with service customers

- A. The customer's bill should present an itemized accounting of every replacement part used and the amount charged for labor.
- B. Whether paid by cash or check, the customer should be presented a properly dated receipt, and the customer's check number should be indicated on the receipt.
- C. Cash or checks should be turned into the main office at the end of each day along with the copy of the customer's receipt and the job number so accounting can properly credit the customer for payment.
- D. Customers who intend to finance repairs should make such arrangements in advance with the main office.

XIII. The most important rule of good service operations — Put it in writing!

**SERVICE OPERATIONS
UNIT XVIII****ASSIGNMENT SHEET #1 — COMPLETE A RETURN GOODS TAG****Background information:**

As a service technician for All Seasons Service Company of 400 West 6th Street in Marshall, Kansas, you are sent to service an inoperative heat pump at the residence of David A. Jones of 304 S. Berry in the same city. Mr. Jones complains that his heat pump, installed less than a year and a half ago, has quit working.

A quick check of the system indicates a compressor burnout. A thorough examination of the compressor indicates the motor windings are slightly burned, and the oil in the unit is very dirty and has a strong smell. You ARE CERTAIN the compressor has suffered a severe burnout and will have to be replaced.

To save time, you call the shop to make sure the burned out compressor is still under warranty, and to have someone deliver a replacement compressor while you remove the bad one. The clerk informs you that the compressor is part of a complete heat pump system which was installed for David Jones on June 3, 1989, and that the compressor is still under warranty. Then, the clerk wants to know the model and serial numbers from the burned out compressor, so you keep him waiting on the phone while you go back to the compressor to find it is a model M-6A with a serial number of M-6A1787. The clerk congratulates you for not getting the information when you first determined the compressor was burned out, and for taking up his time on the phone.

You remove the old compressor while the new one is being delivered from the shop, complete the replacement relatively quickly, and Mr. Jones is pleased his heat pump is working again. Then, Mr. Jones wants to know if the replacement compressor has the same five-year warranty as the original. Since you are not sure, you call the shop and the clerk tells you that the new compressor is warrantied for the balance left on the five-year warranty of the original compressor. Be sure to note the model and serial numbers of the replacement compressor so the new warranty can be mailed to Mr. Jones. The clerk again thanks you for taking up his time on the phone.

At the end of the day, you return to the shop, complete your Job Ticket #B-128, dated August 4, 1990, sign it, and place it in the bookkeeper's "In" basket.

Directions: From the background information given above, complete the return goods tag in Figure 1 and answer the questions that follow (refer to items VI and VII in the Information Sheet before starting.)

ASSIGNMENT SHEET #1

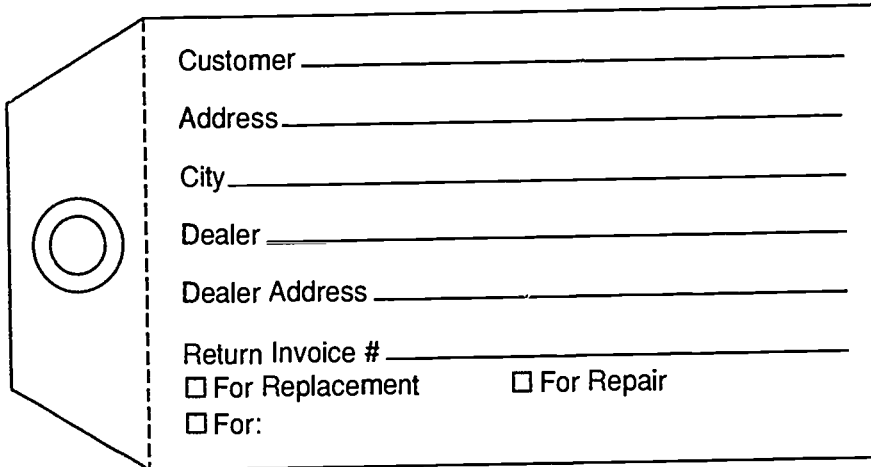

Customer _____

Address _____

City _____

Dealer _____

Dealer Address _____

Return Invoice # _____

For Replacement For Repair

For:

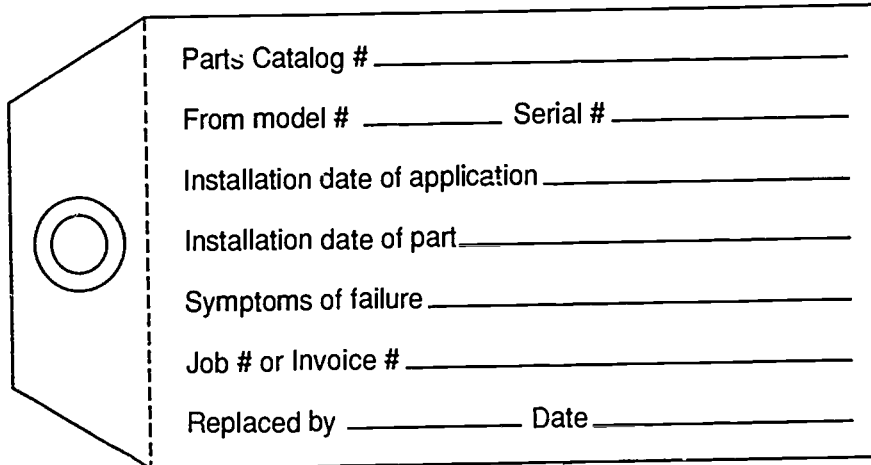

Parts Catalog # _____

From model # _____ Serial # _____

Installation date of application _____

Installation date of part _____

Symptoms of failure _____

Job # or Invoice # _____

Replaced by _____ Date _____

Questions:

1. As you begin to fill out the return goods tag, you realize that everyone in the shop has left and you don't know what the return invoice number is. What would you do?

2. As you continue filling out the return goods tag, you realize you don't have a parts catalog number. What would you do?

3. As you finish filling in the return goods tag, you realize there is no separate dealer's tag to tear off and leave with the shop. What would you do?

4. What business management rule applies to all of the above questions?

**SERVICE OPERATIONS
UNIT XVIII**

ANSWERS TO ASSIGNMENT SHEET #1

	Customer _____ <u>David A. Jones</u> _____
	Address _____ <u>304 S. Berry</u> _____
	City _____ <u>Marshall, Kansas</u> _____
	Dealer _____ <u>All Seasons Service</u> _____
	Dealer Address _____ <u>400 W. 6th, Marshall, KS</u> _____
	Return Invoice # _____
	<input type="checkbox"/> For Replacement <input type="checkbox"/> For Repair
	<input type="checkbox"/> For:

	Parts Catalog # _____
	From model # _____ <u>M-6A</u> _____ Serial # _____ <u>M-6A1787</u> _____
	Installation date of application _____ <u>June 3, 1989</u> _____
	Installation date of part _____ <u>June 3, 1989</u> _____
	Symptoms of failure _____ <u>Burned windings, dirty oil, strong smell</u> _____
	Job # or Invoice # _____ <u>B-128</u> _____
	Replaced by _____ <u>Your Name</u> _____ Date _____ <u>8-4-90</u> _____

1. Put in writing that you need a return invoice number, what you need it for, and leave the note on the desk of someone who can get it for you.
2. Put in writing that you need a parts catalog number, what you need it for, and leave a note on the desk of someone who can get it for you.
3. Put in writing that you need a copy of the complete return goods tag, and leave the note on the desk of someone who can get it copies for you.
4. Put it in writing!

**SERVICE OPERATIONS
UNIT XVIII**

TEST

Name _____ Score _____

1. Match the terms on the right with their correct definitions.

- | | | | |
|----------|--|----|---------------------|
| _____ a. | The ordered activities of accounting, scheduling, inventory control, and personnel supervision that contribute to safe and effective performance, good customer relations, and continued sales and service | 1. | Equipment file |
| _____ b. | A file for retaining records of the type of heating and cooling equipment each customer has | 2. | Warranty |
| _____ c. | A file used to remind people of important things to do at specific future dates | 3. | Suspense file |
| _____ d. | A written statement that a piece of equipment installed to manufacturer's specifications will be guaranteed for a specific length of time | 4. | Business management |

2. Complete statements concerning objectives of good service operations. Circle the material that best completes each statement.

- a. Maintain proper records of in-house and (factory) (mobile) inventory.
- b. Maintain proper records of installations, service calls, and (maintenance) (trouble) calls.
- c. Maintain helpful records concerning customer equipment (complaints) (warranties).
- d. Maintain records to assist in follow-up contact with customers who have indicated interest in (operations) (add-on) or new equipment.
- e. Promote punctuality and professional performance with (careful scheduling) (in-house training).
- f. Promote safety on the job and the safe use of company (vehicles) (tools).
- g. Maintain professional standards that will eliminate the prospects of customer complaints or costly (legal activity) (repairs).
- h. Maintain records which will assist in evaluating employee (attitude) (performance).

TEST

3. Select true statements concerning guidelines for maintaining inventory. Place an "X" beside each true statement.

- a. Inventory should be carried in every service vehicle.
- b. Service personnel should record parts and materials used on every job, and submit a complete inventory report at least once a month.
- c. Service personnel should include in the inventory report a list of tools or equipment lost or damaged or any equipment that needs repair.

4. Select true statements concerning guidelines for maintaining records of installations, service calls, and maintenance calls. Place an "X" beside each true statement.

(NOTE: To be a true statement, all parts of the statement must be true.)

- a. All installations should be recorded on a form suitable for filing and include:

- 1) Customer's name, address and phone number
- 2) Date of installation
- 3) Company job number
- 4) All technical information concerning basic equipment and system design, including sizes of belts and filters
- 5) All equipment or component warranties
- 6) A signed statement from the installation supervisor that the customer has been instructed in correct operation and maintenance of the system

- b. All service calls should be recorded on a form suitable for filing and include:

- 1) Customer's name, address and phone number
- 2) Date of service call
- 3) Company job number
- 4) Customer complaint
- 5) Description of the problem
- 6) How the problem was corrected and the parts or materials used to repair or replace equipment
- 7) Who made the service call and how long it took

TEST

- 8) A record of the expense to the customer, broken down to show cost of individual items and labor charges
- 9) All information available concerning type of equipment, its approximately age, and any discussions service personnel had with the customer concerning add-on or replacement equipment
- ____c. All maintenance calls should be recorded on a form suitable for filing and include:
- 1) Customer's name, address and phone number
 - 2) Date of maintenance call
 - 3) Company job number
 - 4) Name of person making the call
 - 5) List of all charges to the customer
5. Complete statements concerning ways to gather information for a good equipment file. Circle the material that best completes each statement.
- a. Encourage service personnel to observe basic equipment and system (components) (design) on each call.
 - b. Have service personnel record type of equipment, Btuh ratings, and approximate (age) (size) of equipment.
 - c. Have service personnel report any information the customer volunteers concerning (problems with) (use of) equipment.
 - d. Have service personnel report any conversations where customers showed an interest in (add-on or new equipment) (completely changing equipment).
 - e. List any unusual (belt or filter sizes) (gas valve types) so that on future service calls, the service truck won't have to make an extra trip back to the stock room for supplies.
6. Select true statements concerning the procedure for handling return goods. Place an "X" beside each true statement.
- ____a. Make sure the warranty is no more than 30 days out of date.
- ____b. Fill out the return goods tag, and be sure it includes:
- 1) Date and address of installation
 - 2) Date of equipment start-up
 - 3) Time service person spent on replacement

TEST

- 4) Serial number of defective component
 - 5) Brief statement of reasons for failure
 - 6) Any information which would assist the manufacturer in checking the malfunction
- ____c. Separate the dealer and manufacturer tags from the return tag and turn the dealer and manufacturer tags into the office.
- ____d. Attach the return tag to the defective component; the tags usually have a wire or a strong cord especially for this purpose, and should be tied securely so they won't come loose in transit.
7. Select true statements concerning special precautions in handling return goods. Place an "X" beside each true statement.
- ____a. Make sure serial numbers of the component are recorded on all three parts of the return tag, the return tag itself, the part for the dealer's files, and the part that goes back to the manufacturer.
- ____b. Double check the component to be returned to make sure the malfunction is permanent.
- ____c. Read return procedures carefully and make sure return goods are sent only to the manufacturer.
- ____d. If there are no written return procedures, do it the way you think best.
8. Select true statements concerning vehicle use, maintenance, and safety. Place an "X" beside each true statement.
- ____a. All vehicles should be safety checked daily, and the check should include:
- 1) Brakes and brake lights
 - 2) Lights and turning signals
 - 3) Oil and antifreeze
 - 4) Tires
- ____b. Start and return mileage should be recorded daily and signed by the operator.
- ____c. Maintenance schedules for oil change, tire rotation, tune up, etc., are not the concern of the operator.
- ____d. City and state maps should be kept in the glove compartment of each vehicle along with a city phone book.
- ____e. Mobile radio equipment should be checked out daily.
- ____f. Vehicles should be washed monthly, and waxed and shined at least every six months.

TEST

9. Select true statements concerning basic rules for scheduling and service calls. Place an "X" beside each true statement.
- _____ a. All service personnel should know the day before where their first call will be the next morning and any other than normal parts or materials they need to take with them.
 - _____ b. All service personnel should know the addresses of additional calls they are expected to make that day, and should inform the office immediately of any situation that creates a need for rescheduling.
 - _____ c. Service personnel going directly to a job site rather than the shop at the beginning of the work day should inform the shop of their arrival at the job site.
 - _____ d. In situations where a house has to be unlocked by an occupant who is at work, or by a neighbor, the office should contact the party and inform them what time the service person will arrive.
 - _____ e. In situations where a customer cannot be home while service work is being performed, the service person should check with the office.
 - _____ f. Make certain the customer gives advance approval of any unexpected increase in costs, especially if the customer has been given an estimate of repair costs, and especially if the cost increase will be considerable.
 - _____ g. Curious children are intrigued with tools and equipment, and parents should be asked politely, in the interest of safety, to keep children away from the work area.
10. Complete statements concerning ways to avoid legal problems with equipment and service. Circle the material that best completes each statement.
- a. Use equipment that is listed by a (local) (national) testing company.
 - b. Install all wiring to code and (customer) (government) specifications.
 - c. Install all equipment according to (manufacturer's) (customer) specifications.
 - d. Never bypass or (jump) (omit) a part.
 - e. Replace all covers and (secure) (label) them well.

TEST

11. Match other operations items on the right with the statements that define their contribution to good service operations.

- | | |
|---|--|
| <p>_____a. These record the daily activity of individual service people, assist with scheduling by recording who does what kind of job best, and provide a basis for evaluating employee performance</p> <p>_____b. Should remind you to make 30, 60, and 90-day phone checks with customers who have new installations, can help to remind a customer that a warranty period is about to expire, and can be used for follow-up contact with service customers who have asked about add-on or new equipment</p> <p>_____c. These provide service people with information concerning customer's name, address, nature of the complaint, and the time the customer expects the service call to be made, and assigns a job number for the purposes of bookkeeping and accounting</p> | <p>1. Suspense file</p> <p>2. Daily reports</p> <p>3. Job orders</p> |
|---|--|

12. Select true statements concerning how to handle accounting and money with service customers. Place an "X" beside each true statement.

- _____a. The customer's bill should present an itemized accounting of every replacement part used and the amount charged for labor.
- _____b. Whether paid by cash or check, the customer should be presented a properly dated receipt, and the customer's check number should be indicated on the receipt.
- _____c. Cash or checks should be turned in to the main office at the end of each day along with the copy of the customer's receipt and the job number so accounting can properly credit the customer for payment.
- _____d. Customers who intend to finance repairs should make such arrangements after the work is done and they know what the exact cost will be.

13. State the most important rule of good business management.
- _____

(NOTE: If the following activity has not been accomplished prior to the test, ask your instructor when it should be completed.)

14. Complete a return goods tag. (Assignment Sheet #1)

**SERVICE OPERATIONS
UNIT XVIII****ANSWERS TO TEST**

1. a. 4
b. 1
c. 3
d. 2

2. a. Mobile
b. Maintenance
c. Warranties
d. Add-on
e. Careful scheduling
f. Vehicles
g. Legal activity
h. Performance

3. a, c,

4. a, b, c

5. a. Design
b. Age
c. Problem with
d. Add-on or new equipment
e. Belt or filter sizes

6. b, c, d

7. a, b

8. a, b, d, e

9. a, b, c, d, f, g

10. a. National
b. Customer
c. Manufacturer's
d. Jump
e. Secure

ANSWERS TO TEST

11. a. 2
b. 1
c. 3

12. a, b, c

13. Put it in writing!

14. Evaluated according to answers to assignment sheet